



DecoSpector 360™ ***Hardware Guide***

MANUAL PART NUMBER: 80602 REV. 02

HARDWARE MODEL NUMBER(S): 77769, 77770, 81507, 81508

Copyright Notice / Contact Us

© 2024 Pressco Technology Inc. All rights reserved.

No part of this manual may be reproduced or transmitted in any form or by any means, electronic or mechanical, including photocopying and recording, for any purpose, without the express written permission of Pressco Technology Inc.

The contents of this manual are furnished for informational use only, are subject to change without notice, and should not be construed as a commitment by Pressco Technology Inc.

Written and designed at:

Pressco Technology Inc. World Headquarters

29200 Aurora Road

Cleveland, OH USA 44139-1847

TEL +1-440-498-2600

FAX +1-440-498-2615

www.pressco.com

Business Hours: Monday - Friday, 8:00am - 5:00pm Eastern Time

Customer Support:

Request technical support and remote support: techsupport@pressco.com

24/ 7 Customer Support (for urgent system help): +1-440-498-2000

e-mail: Schedule a service visit: dispatch@pressco.com

Request technical support and remote support: techsupport@pressco.com

Customer Service Fax: +1-440-498-4761

Table of Contents

Chapter 1 Introduction	6
About this guide	6
Safety Considerations	7
Static Discharge Protection	7
Chapter 2 Safety Information	8
Health Warning - Photosensitive Epilepsy	8
Symbols Used With This System	9
Arc Welding Warning	10
Product Label	10
Warning Devices	11
Light Tree	11
Residual Risk	11
Intended Use	11
Prohibited Use	12
Personal Protective Equipment	12
Personnel Safety	12
Lifting Heavy Objects	14
Authorized Users	14
Spare Parts Usage	15
Chapter 3 Specifications - DecoSpector 360	16
Deco Can Printing Position Requirement	16
Measurements	17
Environmental Conditions	19
Electrical Specifications	20
Sound Pressure Level	20

Chapter 4 Declaration of Conformity - DecoSpector 360	21
Chapter 5 Installation	23
Recommendations Prior to Installation	23
Instructions for Safe Assembly Operations	23
Shipping and Handling	23
DecoSpector 360 Components	25
Assembly, Location, and Mounting Requirements	27
Install the Inspection Module	27
Stability of the Control Enclosure	29
Utilities to be Supplied by Customer	30
Protective Earthing	30
Electrical Connections for cabinets 77769, 77770, 81507, and 81508	31
Deco Reject Valve Pneumatic Diagram	31
Commissioning	31
Chapter 6 Control Enclosure and Operator Interface Hardware	32
USB Ports	33
Biometric Login Device	33
Power On and Off at the Control Enclosure	34
Accessing the Internal Components with Power Off	35
Lockout Procedure	36
Accessing the Internal Components with the Power On	37
Chapter 7 Components and Wiring Diagrams	38
Deco Interconnect Diagram	38
External Connections	39
Components Inside the Control Enclosure	40
Vision Processor Panel	42
Fuse Replacement	42
Wiring Diagrams for Control Cabinet	43

Wiring Diagrams for Inspection Modules	54
PLC Correlation, Extended I-O Opto Relays 78746 (Optional)	69
PLC Correlation Opto Relays 78257 (Optional)	76
8 Port I-O Box	81
4 Port I-O Box	81
Chapter 8 Inspection Module	82
Chapter 9 Troubleshooting	84
Oil or Dirt on the Inspection Tunnel Windows	84
Full Power Cycle for DecoSpector	85
Chapter 10 Deco Extended IO	87
Extended I-O Signals	87
Defect Group I-O	89
Extended I-O Board	91
Extended I-O Circuits	91
Chapter 11 Maintenance	93
Maintenance Cautions	93
Preventive Maintenance Frequency	93
Clean the Control Cabinet Filters	94
Service Frame	95
Use the Service Frame to Lift the Module for Maintenance	96
Clean the Tunnel Windows	98
Replace the Filter-Regulator Filters	100

Chapter 1 Introduction

Welcome! Congratulations on your purchase of a Pressco DecoSpector 360™ system! The DecoSpector is an inspection system that performs extensive product quality checks on 100% of the decorated surface area of printed beverage cans.

The DecoSpector system locates the following on cans:

- Printing flaws (voids, spots, smears, cut blanket, etc.)
- Color conformity to specifications (drift, light, dark, contamination)
- Color to color registration (ghosting, shadows, shifts)
- Missing print coat (clear or white)

The DecoSpector system correlates defects to print blanket and mandrels, so that you can quickly locate problematic areas and make repairs or adjustments.

The system consists of a touch screen operator interface, a control enclosure, an inspection tunnel, and the associated cables connecting the components.

About this guide

This guide provides information about system features and technical specifications. It is intended for Administrator-level users.

This guide provides the necessary information to operate a DecoSpector 360 system that is properly installed and programmed. Some machine functions require specialized training. This training is available from Pressco and may be conducted at your plant or at Pressco in Cleveland Ohio, USA. For more information, contact Pressco's training department.

This manual:

- Is considered an integral part of the machine and should be kept handy for future reference as long as the system is being used in your plant
- Is your responsibility to keep in good condition, in a dry place, and ready for consultation by the authorized users of the system
- Contains the technology implemented at the time of selling and supplying the system and shall not be considered inadequate in case of technological enhancements in the machine or in the manual's illustrations

Related publications:

- DecoSpector 360 Operator Guide, intended for Operator-level users, and contains every day usage information.
- DecoSpector 360 Software Guide, intended for Administrators, and contains all the software functions of the system.

The following types of alerts may appear in this guide:



DANGER! - Danger messages alert you to specific conditions that can cause serious or fatal personal injury. Danger messages give you important information which must be observed to prevent injury.

 **WARNING:** - Warning messages indicate information which must be observed to prevent injury, data loss, or equipment damage.

 **CAUTION** - Caution messages indicate important information which must be observed to prevent: loss of data, poor system performance, or equipment damage.

Note: Notes contain special information that warrants being set off from the body text as shown here.

 **IMPORTANT** - Indicates prerequisites or information that must be observed to complete or understand a concept or task.

TIP: Provides helpful hints for completing a task.

Safety Considerations

Observe the following safety warnings when operating the system or working near it:

 **WARNING** - Potential for projectiles to strike persons and cause injury. Keep clear of reject devices.

 **WARNING** - Sensitive electronics and High Voltages may be exposed. Keep Processor Cabinet/ Electrical Control Box door closed.

Static Discharge Protection

 **Caution** - Electronic components can be damaged by static electricity discharge.

Always observe the following precautions before removing, installing or handling any electronic components within the Inspection System:

- Wear an anti-static wristband which is grounded to the Inspection System.
- Stand on an anti-static, grounded floor mat, and lay circuit boards on the mat during any board replacement.
- Keep circuit boards in static shield bags when storing and transporting. Ensure the bag is sealed.

Chapter 2 Safety Information

This section contains operator safety information that must be read before operating or servicing the system.

 **WARNING** - This product contains no operator serviceable parts. Refer servicing to qualified personnel. To prevent electrical shock do not open cabinet doors whilst power is connected.

 **WARNING** - Do not, under any circumstances, tamper with sealed machine parts or devices. This could result in the removal of protections that might create potentially hazardous conditions.

 **CAUTION** - Possible hazardous optical radiation from LEDs. Do not stare at lamps.

Observe the following safety warnings when operating the system or working near it:

 **WARNING** - Potential for projectiles to strike persons and cause injury. Keep clear of reject devices.

 **WARNING** - Sensitive electronics and High Voltages may be exposed. Keep Processor Cabinet/ Electrical Control Box door closed.

Health Warning - Photosensitive Epilepsy

 **WARNING: PHOTOSENSITIVE EPILEPSY/ SEIZURES**

A small percentage of individuals may experience epileptic symptoms or seizures when exposed to certain patterns or flashing lights. Exposure to the flashing lights in vision inspection systems may also trigger epileptic symptoms or seizures in these individuals. These flashing lights may trigger epileptic symptoms or seizures in persons who have no history of epileptic symptoms or seizures. If you, or anyone in your family has an epileptic condition or has had seizures of any kind, consult your physician before operating this machinery.

IMMEDIATELY DISCONTINUE use and consult your physician if you experience any of the following symptoms while operating this machinery:

- Dizziness
- Altered vision
- Eye or muscle twitches
- Loss of awareness
- Disorientation
- Seizures
- Any involuntary movement or convulsion

Epileptic symptom or seizure triggers vary from person to person. Some common triggers are:











- Flashing lights used for vision inspection systems or fire alarms
- Certain video games or TV broadcasts containing rapid flashes or alternating patterns of different colors
- Bright, contrasting patterns such as white bars against a black background
- Flashing white light followed by darkness
- Stimulating images that take up your complete field of vision, such as being very close to a TV screen or computer monitor
- Certain colors, such as red and blue

If you encounter something that might trigger epileptic symptoms or seizures without warning:

- Do not close your eyes (this could cause a flicker effect)
- Do not look directly at the flashing lights or trigger source
- Do cover one eye with the palm of your hand immediately
- Do turn away from the flashing lights or trigger source

Symbols Used With This System

The following symbols are used on or near the Pressco system. Be aware of potential risk hazards.

Symbol	Meaning
	CAUTION: Risk of danger. Refer to accompanying user documentation before use.
	WARNING: Risk of electric shock
	WARNING: Arc flash and shock hazard
	WARNING: Risk of electrical shock
	WARNING: Risk of burns from hot surface
	WARNING: Hand crush hazard
	On (supply)
	Off (supply)
	Alternating current
	Protective conductor terminal

	<p>Warning: Arc flash and shock hazard</p>
	<p>Warning: UPS voltage present when power is off</p>
	<p>Warning: UPS Disconnect</p>
	<p>Warning: Electrical interlock</p>
	<p>Danger: shock and arc flash explosion hazards</p>

Arc Welding Warning

⚠ WARNING - Potential equipment damage can occur if the vision equipment is not fully powered down prior to any arc welding performed on the line where the vision equipment is installed, specifically but not limited to our encoders.

Product Label

The following illustration shows an example label that you will find on the system components.

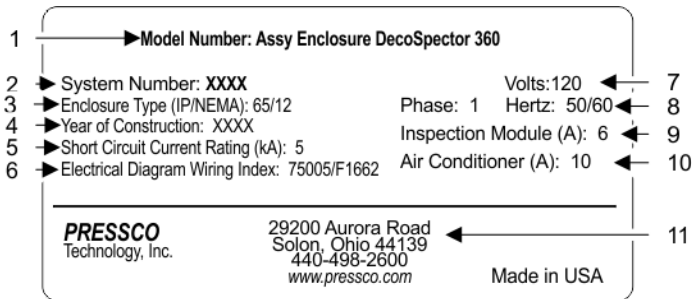

- 1) Name of component
- 2) Serial number
- 3) Enclosure type
- 4) Year of construction
- 5) Short circuit current rating (kA)

- 6) Electrical wiring diagram number (Pressco number)
- 7) Voltage range in Volts AC
- 8) Frequency range in Hertz (Hz)
- 9) Inspection module current rating
- 10) Air conditioner current rating
- 11) Place of construction

Warning Devices

The Pressco system has warning devices that indicate system failure or report excessive defects or warnings for your production line. These include an optional light tree, alarms and indicators on screen, and audible warnings (depending on system).

Light Tree

The optional light tree is mounted on a pole in a customer-specified location.



The light tree color segments represent each alarm or system condition. A color segment may appear for more than one alarm condition.

Residual Risk

The Pressco system has been designed to minimize any danger of personal injury. However, the system uses rejection devices to remove defective product from the production stream. Also, the electronics cabinets contain risk of shock if they are opened.

Observe the following safety warnings when operating the system or working near it:



WARNING - Potential for projectiles to strike persons and cause injury. Keep clear of reject devices.



WARNING - Sensitive electronics and High Voltages may be exposed. Keep Processor Cabinet/ Electrical Control Box door closed.

Intended Use

Type of Process - The Pressco system is intended to monitor container and other special manufacturing processes and identify non-conforming product.

Intended Use - The Pressco system is designed and constructed for use in an indoor industrial environment, always sheltered from the weather.



Space Required - The Pressco system and accompanying sensors must be installed in a place that will enable safe and easy installation, size changeover, user operation, and maintenance procedures.

Prohibited Use

 **WARNING** - If this instrument is not used as specified, the protection provided by the equipment could be impaired. This instrument must only be used in a normal condition (in which all means of protection are intact).

 **Important** - The Pressco system should NOT be used for any purpose other than specifically indicated in the section titled "**Intended Use**" on the previous page.





The following uses are not intended:

-  Use in an explosive environment
-  Use in a flammable environment
-  Use in a damp, moist, or wet environment, except where specifically indicated

Personal Protective Equipment

 **Important** - Always follow the safety requirements of your plant in addition to the recommendations below.

We recommend, at minimum, use of the following Personal Protective Equipment (PPE):

	Protective clothing
	Protective gloves
	Protective ear plugs or headphones
	Protective eye wear
	Protective foot wear



Personnel Safety

The following rules are recommended to ensure the safety of personnel in charge of machine operation and maintenance.







During machine operation:









Only one operator is needed to operate the machine. All others must keep at a safe distance.

	<p>Operators must be familiar with all machinery connected to the Pressco equipment and know how to use emergency stop devices.</p> <p>Note: the emergency stop devices may not be connected directly to the Pressco equipment, but it is important to know how to use them.</p>
	<p>Before putting the Pressco system online, the operator must ensure that all safety devices used with all connected machinery are in place and operational.</p> <p>Do not operate with guards removed.</p>
	<p>The operator must maintain maximum focus on his work and be alert throughout his shift. If this is not the case, immediately inform the shift supervisor.</p>

When carrying out maintenance or repair work:

	<p>Disconnect master switch. For switch locations, refer to the Power Up and Power Down section.</p>
	<p>Before starting the machine, ensure that no person is close to the machine.</p>
	<p>If maintenance or repair requires the disconnection or removal of safety or protection systems, this operation must be supervised by authorized personnel who must ensure the prevention of personal injury or damage to the machine. All machine movements must be performed with limited speed and limited movements.</p>
	<p>Maintenance or repair work on electrical components must be carried out exclusively by authorized, trained personnel. When running tests with power connected, you must strictly comply with the rules provided.</p>
	<p>Personnel working on higher parts of a machine must wear a harness and hook it on to the structure and must always move with extreme caution.</p>
	<p>Never perform lubrication or maintenance procedures on mechanical parts with the machine running.</p>

For your safety, do not:

-  Open safety guards during machine operation
-  Perform maintenance and repair while the system is running
-  Lean on the machine
-  Sit on the machine components
-  Use the machine for purposes other than those listed in this manual
-  Modify parts of the machine



Allow unqualified personnel to operate or perform maintenance procedures on the machine

Lifting Heavy Objects



CAUTION - Some components are heavy. Take proper precautions to prevent personal injury or damage to equipment. If you are not capable of lifting the object alone, ask a capable person to help lift the object, or use a mechanical lifting device

The components do not have handles to lift the equipment. Be sure to:

- Lift equipment from the bottom - do not use wires, brackets, nor other protrusions
- Keep fingers away from sensor lenses to keep the equipment clean
- Proceed slowly



WARNING- The Pressco cabinets must NOT be lifted by one person. Use a mechanical lifting device, and ask another person to assist you.



Do not twist your body when moving the load. Instead take small steps with your feet turning until you are in the correct position.

To safely lift equipment:

1. Stand close to the load and center yourself over it with your feet shoulder width apart.
2. Tighten your abdominal muscles.
3. Keeping your back straight, bend your knees and squat down to the floor.
4. Get a good grasp on the load with both hands.
5. Keeping the load close to your body, use your leg muscles to stand up lifting the load off the floor. Your back should remain straight throughout lifting, using only the muscles in the legs to lift the load.
6. To place the load in the appropriate spot, bend at the knees using only your leg muscles to lower the load.

Authorized Users

Trained machine operators, mechanic and electrical maintenance staff, and plant managers are considered authorized users of the Pressco system. These users should carefully read the information contained in this manual. The plant manager must ensure that the safety recommendations included in this manual are observed.



WARNING - Allowing workers who are unfamiliar with the production process to operate the Pressco system could result in hazard risk.

If you are unclear about any part of this manual, contact Pressco Technical Support.



Important - No worker should ever operate the system outside of his/ her own area of competence and responsibility.

Proper Operation: - Only one worker is to operate the system at any given time. The correct position for the operator is in front of the user interface monitor or control enclosure (if applicable).

Repairs: - Any repair on the system shall be carried out exclusively by Pressco Technology Inc. service personnel or by other service expressly authorized by Pressco Technology Inc.

Spare Parts Usage

The following restrictions apply to replacing parts:



WARNING - Using spare parts that are not designed to Pressco's specifications can compromise the safety and effectiveness of the Pressco system.

- The use of parts that are not within Pressco's design specifications is prohibited. This prohibition applies in particular when the parts involved contain or are connected with safety devices.
- Before resuming production, make sure all safety devices are in working order.

Pressco Technology Inc. shall not be liable in any way if any of the above-described directions are not complied with.

To obtain a spare parts list, contact the Spare Parts department at Pressco: SpareParts@pressco.com. Or call +1-440-498-2000 (Monday - Friday 8AM - 5PM Eastern time).

In addition, Pressco's technicians are available to help customers, in their own plant, to solve any problem that might arise during use and maintenance of the system.

Chapter 3 Specifications - DecoSpector 360

This instrument has been designed and tested in accordance with Publication EN61010-1 (2010) Safety Requirements for Electrical Equipment for Measurement, Control and Laboratory Use and has been supplied in a safe condition. The instruction documentation contains information and warnings which must be followed by the user to ensure safe operation and to maintain the instrument in a safe condition.

Deco Can Printing Position Requirement

Specification

We require that two millimeters (2mm) of bare aluminum be present at the top of each can. This is required for proper part location. Less than 2mm may result in part location issues, which impacts inspection.



Measurements

The following topics show the measurements for the DecoSpector cabinet, inspection module, and service frame.

Deco Control Enclosure Measurements

This drawing shows measurements for cabinet numbers 77769, 77770, 81507, and 81508.

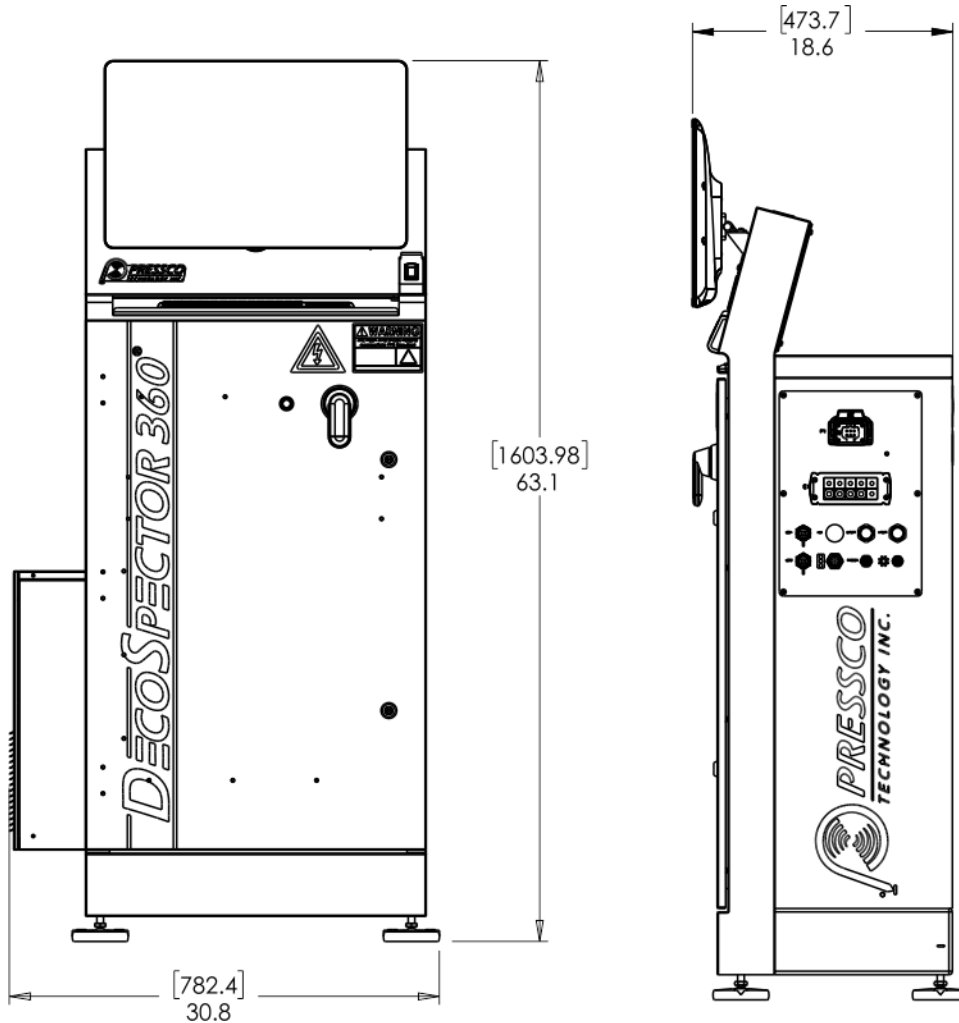

The measurements are in inches. The numbers in brackets are in millimeters.

Deco Inspection Module Measurements

⚠ CAUTION - This object is heavy. Review the section on lifting heavy objects before moving this object. "Lifting Heavy Objects" on page 14

Dimensions of inspection modules and service frames

Note: The dimensions listed below include the Service Frames on which the modules are mounted

Note: measurements do not include connectors

The illustration below shows the measurements of the standard (pin stripper) inspection module DS6 (model 76610). Other module measurements are listed in tables below.

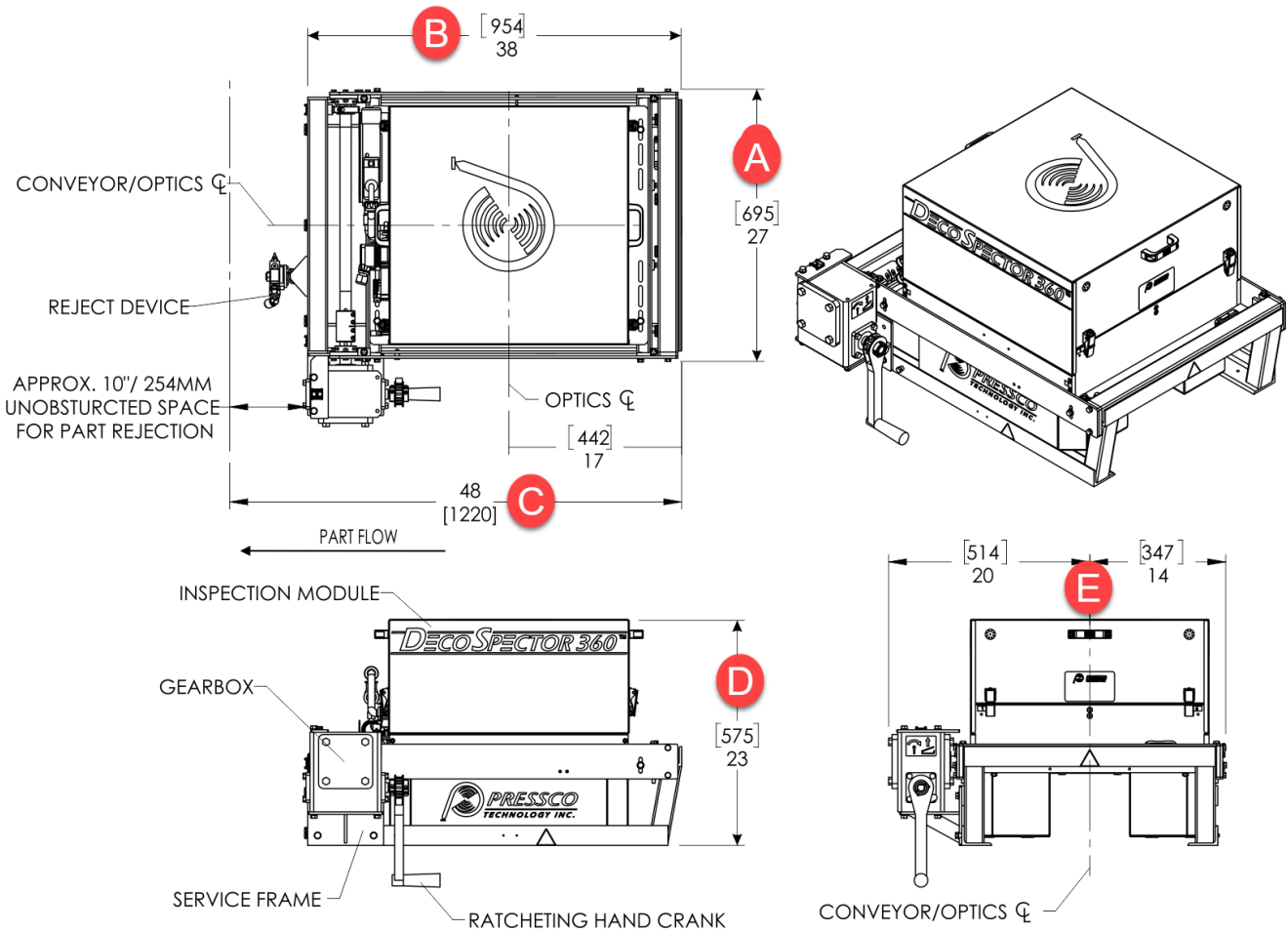

- NOTES:
1. MODULES SHOWN IN INSPECTION POSITION.
 2. FRAME SHOWN IN ONE OF SEVERAL POSSIBLE CONFIGURATIONS.
 3. GEARBOX AND REJECTOR CAN BE LOCATED ON EITHER SIDE OF CONVEYOR.
 4. FRAME TO CONVEYOR MOUNT LEGS NOT SHOWN.

Standard (pin stripper) inspection module DS6 (model 76610)

A	Width	27 inches [695 mm]
---	-------	--------------------

B	Length	38 inches [954 mm]
C	Length with reject device and optics (10 inches necessary for rejection)	48 inches [1220 mm]
D	Height	23 inches [575 mm]
E	Width from conveyor centerline	20 inches [514 mm] and 14 inches [347 mm]

XL (pin stripper) inspection module DS7 (model 76620) and DS9 (model 80134)		
Width		33 inches [847 mm]
Length		44 inches [1108 mm]
Length with reject device and optics		53 inches [1360 mm]
Height		25 inches [641 mm]
Width from conveyor centerline		23 inches [590 mm] and 17 inches [424 mm]

Standard (pin stripper) inspection module DS8 (model 80125)		
Width		27 inches [695 mm]
Length		38 inches [954 mm]
Length with reject device and optics		48 inches [1220 mm]
Height		24 inches [613 mm]
Width from conveyor centerline		20 inches [514 mm] and 14 inches [347 mm]

XXL inspection module (model 83226)		
Width		37 inches [939.80 mm]
Length		41 inches [1041.40 mm]
Length with reject device and optics		42.06 inches [1068.40 mm]
Height		25.79 inches [655.07 mm] (34.85 inches [885.19 mm] with stand)

Environmental Conditions

The DecoSpector 360™ system is designed to be safe in the following environmental conditions:

Note: Please consult Pressco Technology Inc. if your environmental conditions are outside of those listed.

Condition	Specifications
Indoor/ outdoor use	Indoor use only
Altitude	Up to 2000 meters

Condition	Specifications
Operating Temperature	5 °C to 50 °C
Storage Temperature	0 °C to 70 °C
Humidity	Maximum relative humidity 80 % for temperatures up to 31 °C decreasing linearly to 50 % relative humidity at 50 °C
Mains supply	Voltage fluctuations up to ± 10 % of the nominal voltage Transient overvoltage typically present on MAINS supply
Overvoltage protection rating	NOTE: the normal level of transient overvoltages is impulse withstand (overvoltage) category II of IEC 60364-4-443.
Rated pollution degree	This instrument is designed for use in Installation Category II and Pollution Degree 2 as per EN61010-1 and EN60664 respectively.



WARNING - This is a Class A product. In a domestic environment this product may cause radio interference in which case the user may be required to take adequate measures.

Electrical Specifications

The following are electrical specifications* for the DecoSpector 360™ control enclosure:

Note: the specifications are current as of the date of this publication and the wiring diagrams included in this publication. If your system was manufactured in a different year, look at the **System Number tag located on your system to see the actual specifications.*

Configuration	Specification - 120 V system	Specification - 230 V system
Voltage Range	120 Vac	230 Vac
Frequency	50/ 60 Hz	50/ 60 Hz
Current	7A for Air Conditioner 6A for Inspection System	3.5A for Air Conditioner 3A for Inspection System

Sound Pressure Level

The (optional) horn on the light tree has a maximum 105dB level at 1 meter distance in front of the horn. Use proper hearing protection as specified by your plant safety instructions.

Chapter 4 Declaration of Conformity - DecoSpector 360

Declaration	<p>The listed product is in conformity with following Union harmonization legislation:</p> <p>Directive 2014/30/EU of the European Parliament and of the Council of 26 February 2014 on the harmonisation of the laws of the Member States relating to electromagnetic compatibility and with Directive 2014/35/EU of the European Parliament and of the Council of 26 February 2014 on the harmonisation of the laws of the Member States relating to the making available on the market of electrical equipment designed for use within certain voltage limits.</p> <p>The Technical Documentation demonstrates the fulfillment of the essential requirements as set out in Annex I of the above Directive.</p>
Manufacturer	<p>Pressco Technology Inc. 29200 Aurora Road Cleveland, Ohio 44139-1847 USA</p> <p>This declaration of conformity is issued under the sole responsibility of the manufacturer.</p>
Product Name	DecoSpector 360™
Referenced harmonised standards to which conformity is declared:	<p>EN 61326-1:2013 Electrical equipment for measurement, control and laboratory use — EMC requirements — Part 1: General requirements</p> <p>EN 55011:2016+A11:2020: Radiated / Conducted Emissions</p> <p>EN 61000-4-2:2009: ESD Immunity</p> <p>EN 61000-4-3:2006 + A1:2008 + A2:2010: Radiated RF Immunity</p> <p>EN 61000-4-4:2004 + A1:2010: EFT Burst Immunity</p> <p>EN 61000-4-5:2006: Surge Immunity</p> <p>EN 61000-4-6:2009: Conducted RF Immunity</p> <p>EN 61000-4-11:2004: Voltage Dips & Interruptions</p> <p>EN 61010-1:2010 Safety requirements for electrical equipment for measurement, control, and laboratory use - Part 1: General requirements</p> <p>2011/65/EU Restriction of Hazardous Substances in Electronic Equipment</p>
Place	<p>Pressco Technology Inc. 29200 Aurora Road Cleveland, Ohio 44139-1847 USA</p>

Signed: Fredrick F. Awig, VP of Engineering & Operations. Signed for and on behalf of Pressco Technology Inc.

Chapter 4

Signed for and on behalf of Pressco Technology Inc., 29200 Aurora Road, Cleveland, OH USA 44139:

AL. VP, ENG. OPERATIONS

Name, Position

Date: 21 April 2021

Chapter 5 Installation

This section contains information about installation requirements and preparations that need to be complete before installing the system.

Recommendations Prior to Installation

Before the machine is installed, the Pressco installer, together with the Customer (or representative) shall check the following criteria in the environment where the machine is to be installed:

- Work required by contract for the installation of the machine has been carried out
- The plant layout drawing that describes where the machine will be installed is the final drawing agreed to by Pressco Technology Inc.
- The space and height required for installation are actually available
- Only the components included in the installation layout are present in the area where the machine is to be mounted. Ensure no machines or components have been added at a later stage that might hinder mounting or make it more difficult. Should this be the case, immediately contact Pressco's Project Engineering personnel to arrange a suitable solution to the problem.

We recommend the following prior to machine installation:

- Transport the machine in its packaging to the area where it will be installed to minimize possibility of damage
- Carefully remove the packaging material and check components for damage
- Check tightness of mechanical components, as they can loosen during transport
- Prepare the compressed air mains line. Before making final connections, ensure that the pipes are clean and free from any debris.

Instructions for Safe Assembly Operations



IMPORTANT - *The site supervisor will be responsible for ensuring that all the various mounting phases are carried out safely and in compliance with current regulations.*

The site supervisor will also be required to make sure that all the members of personnel involved in the mounting operations comply with said regulations.

Shipping and Handling

Pressco Technology Inc. ships unassembled components in packing cases designed to protect the contents during handling and from exposure to weather.

Unless otherwise specified in the contract with the machine order, the Customer shall supply Pressco Technology Inc. with the means and equipment necessary for the unloading, lifting, and handling of machine parts. Pressco Technology Inc. deems it important to have one of their technicians supervise the process of unloading, handling, and lifting the machine. The technician can give useful advice as to the logical sequence in which the components should be unpacked and positioned for ease of assembly.

⚠ WARNING - Only qualified personnel must be involved in the operation of unloading, handling, and lifting the machine. Pressco Technology Inc. shall not be liable for damage to components and/or personal injury resulting from the involvement of unauthorized personnel and/or failure to comply with the directions provided in this manual in relation to lifting and transport.

! Important - The site supervisor will be responsible for ensuring that all the various mounting phases are carried out safely and in compliance with current regulations.

After the machine is delivered, check for any damage that might have occurred during shipping. In case of damage, contact Pressco Technology Inc.

In handling the machine, always keep it close to the ground.



We recommend using a forklift truck with adequate capacity and forks to suit the weight to be lifted (machine plus packaging).

The dimensions and weight of typical crates are listed below. You will receive more than one crate. The size and weight of the crates may be more depending on your order.

! Note: the following values are from the standard DecoSpector cabinet and original DecoSpector inspection module. The newer and larger modules will have larger crates and will weigh more.

Size	Crate A: 99.06 x 124.46 x 195.58 cm [39 x 49 x 77 inches] Crate B: 114.3 x 129.54 x 119.38 cm [45 x 51 x 47 inches]
Weight	Crate A: 322.05 kg [710 lbs.] Crate B: 332.48 kg [733 lbs.]

Hoisting

The machine is packaged in a wooden box, inside which the parts are individually packaged to prevent shock and sudden movements during transport. It is anchored onto a pallet.

⚠ WARNING - To prevent personal injury in the event that the machine or packaging box should fall, ensure that during hoisting operations no person is standing within the range of action of the hoisting machines.

Hoisting, transporting and placement operations should be supervised by qualified technical staff trained in these specific areas.

Before performing any movement, you should always ensure that the hoisting means and equipment (ropes, hooks, etc.) are suitable for lifting the weight and also verify its stability.

! If using a fork lift truck, ensure that the forks extend beyond the opposite side.

Before you start moving the machine, check the stability of the element to be transported.



Storing

The machine should be stored indoors, still packed. Maintain regular temperature and humidity.

DecoSpector 360 Components

The following diagram shows the major components of the system. Your plant may have a different configuration based on your inspection requirements.

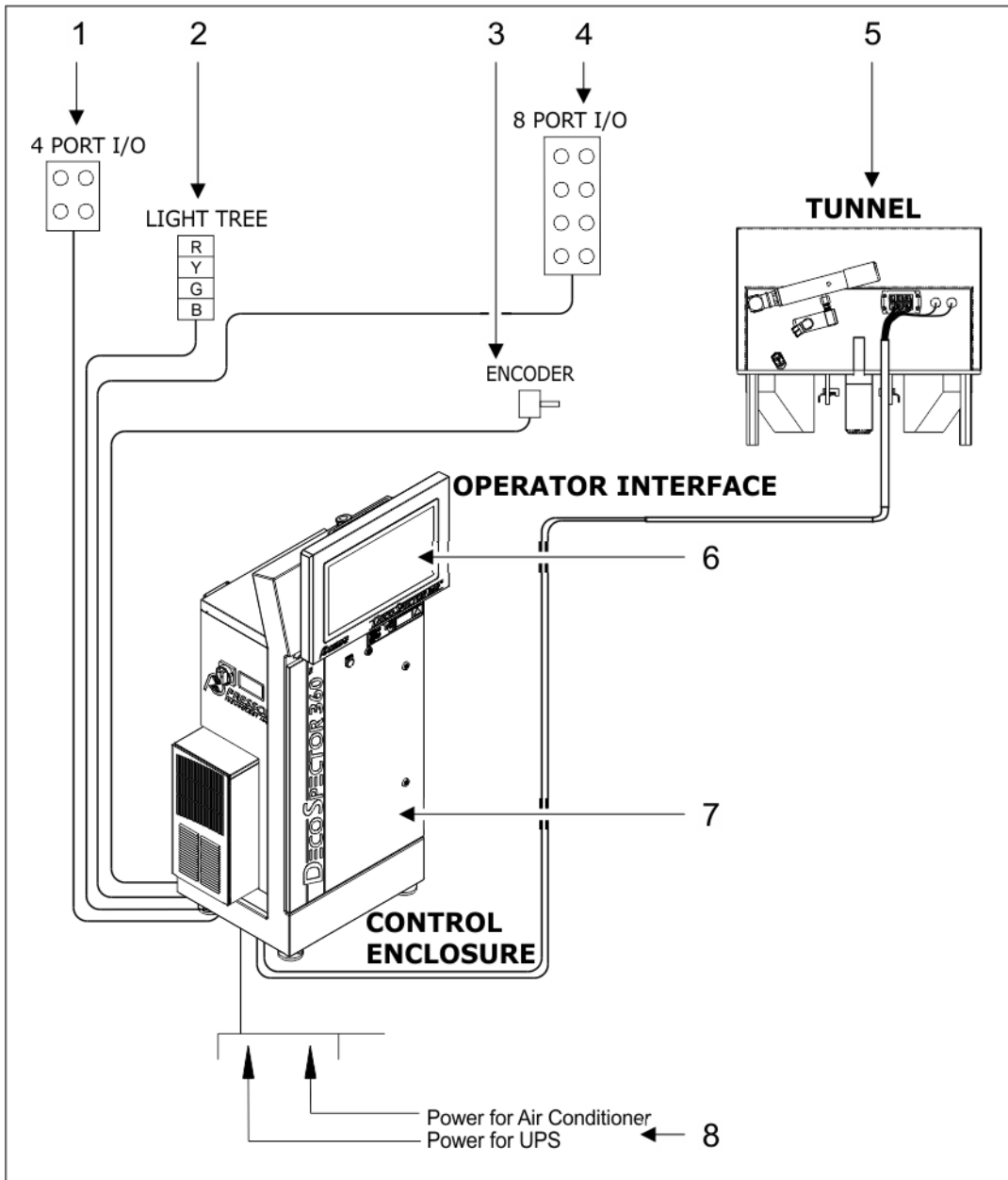

- 1) 4-port I/O box - (correlation signals) located near the correlation sensors
- 2) Light tree - location is plant-specified
- 3) Encoder - located near the tunnel
- 4) 8-port I/O box - (part detection and rejection signals) located near the tunnel
- 5) Tunnel - also called Inspection Module, mounted on a Service Frame
- 6) Operator interface - in some plants, this interface may be located in a remote location from the control enclosure
- 7) Control enclosure
- 8) Power input for air conditioner and UPS

Assembly, Location, and Mounting Requirements

Installation

Pressco Technology Inc. recommends that the machine be installed and assembled by Pressco's specialized technicians. This is of vital importance for correct machine operation.

⚠️ WARNING - Pressco Technology Inc. shall not be liable in case of failures or damage to property and/or personal injury resulting from or connected with assembly if this has been carried out by unauthorized personnel, or is not in compliance with the indications given in this manual.

To carry out production and cleaning/ servicing operations, it is important for the machine to have a minimum amount of space all around and away from walls.

Ventilation

Leave 1 meter [39 inches] clear around the control enclosure. Place the system components in a position with adequate ventilation to allow proper air flow through the air filters.

Install the Inspection Module

Installation should be carried out by Pressco personnel. Refer to the installation drawings.

⚠️ Caution - The user interface and inspection module must **NOT** be lifted by one person. Use a mechanical lifting device, and ask another person to assist you.

Lift the Service Frame

Using a forklift or other mechanical lifting device, lift the service frame using the three straps that are installed by Pressco prior to shipping. Use a hook, another strap (as shown below), or your plant's preferred method.

Place the service frame in the desired location and mount as specified in the installation drawings.

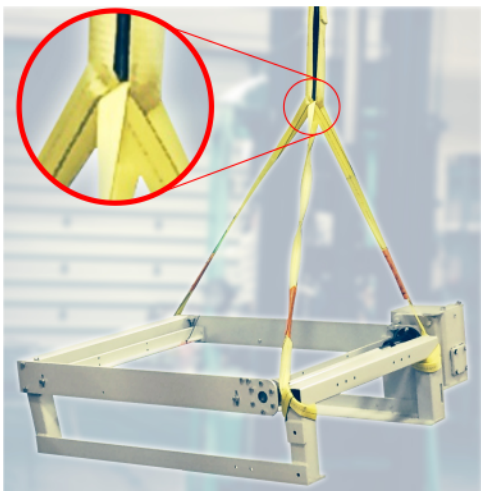

Lift the Module

Using a forklift or other mechanical lifting device, lift the module using the two straps that are installed by Pressco prior to shipping. Use a hook, another strap, or your plant's preferred method.

Place the module on top of the service frame. Secure the module in place with screws, as specified in the installation drawings.



Secure the Module to the Service Frame

Secure the module to the service frame. Refer to the installation drawings for instructions.

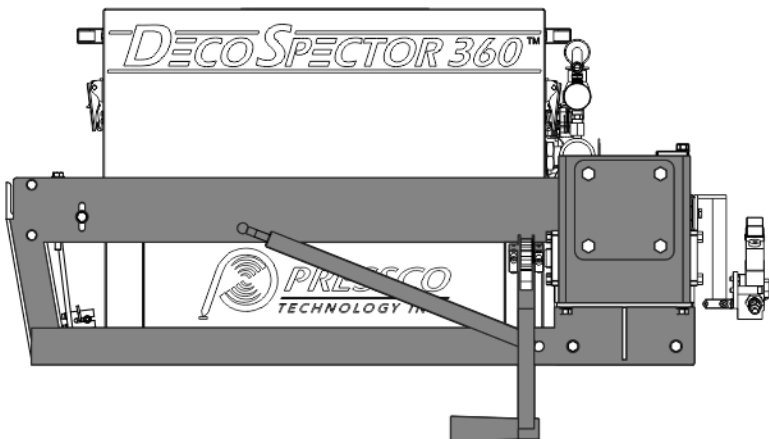

Stability of the Control Enclosure

Ensure the stability of the control enclosure. Also refer to the directives in the Personnel Safety section.

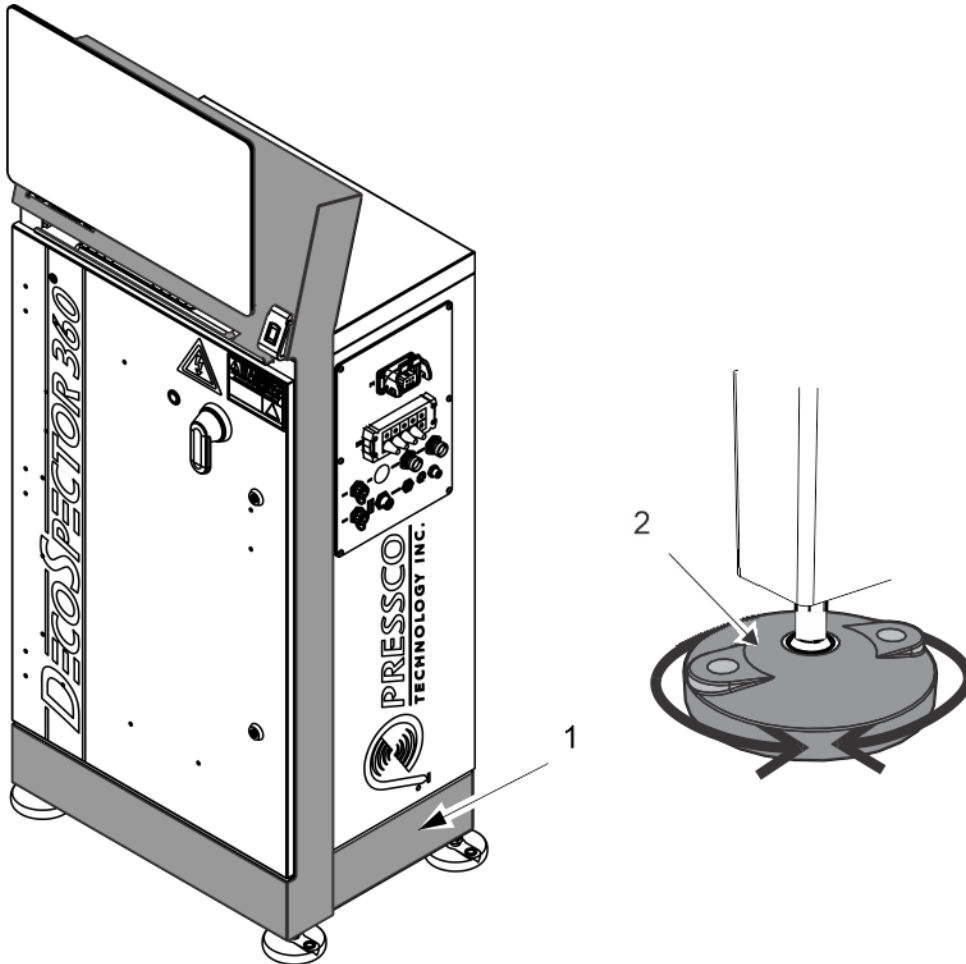

To make sure the control enclosure is stable:

1. Make sure that the control enclosure frame [item 1] is secured properly.
2. Adjust the feet [item 2] to level the control enclosure. Proper leveling can help ensure proper operation.

Securing to Floor

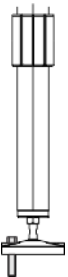

The ground under the machine must be sufficiently solid to sustain the machine mass at the support points. In addition, the floor must be free of bumps, grooves and other surface irregularities. The surface must be flat enough so that the leveling feet of the machine bear weight across their entire surface.

Attach the machine to the floor by installing M12 x 50mm lag bolts into the floor through the hole on the frame foot pad. Do this on one hole in each foot.

Utilities to be Supplied by Customer

The following utilities are required to operate the DecoSpector system. Before making connection, make sure the utility matches the technical specifications. More than one connection of the utilities may be required depending on the number of modules installed. Refer to specific wiring diagrams.

WARNING - This is a Protection Class 1 Product (provided with a protective earthing ground terminal). The equipment must only be connected to a supply that is also provided with a protective earth conductor. Any interruption of the protective conductor inside or outside of the equipment is likely to make the instrument dangerous. Intentional interruption is prohibited.

Utility	Requirements
Air supply for rejection device	Pipe size must be such that there will be no pressure decrease during machine operation. Air must be dry and free of oil.
Electrical supply	Provide one each electrical socket to comply with: " Electrical Specifications " on page 20 (use the specifications that apply to your system)
Internet connection (optional)	Provide a shielded ethernet cable to use Pressco's remote support through the Internet.

Protective Earthing

This product must be grounded (earthed). If it should malfunction or break down, grounding provides a path of least resistance for electric current to reduce the risk of electric shock.



DANGER - Improper connection of the equipment grounding conductor can result in a risk of electric shock. Check with a qualified electrician or service technician if you are in doubt as to whether the product is properly grounded.

Cord Connected Equipment

The product will be equipped with a supply cord having an equipment grounding conductor and a grounding plug. The plug must be plugged into an appropriate outlet that is properly installed and grounded in accordance with local codes and ordinances.

Do not modify the plug provided with the product - if it will not fit the outlet, have a proper outlet installed by a qualified electrician.

Cable Direct

This product must be connected to a grounded metal, permanent wiring system, or an equipment grounding conductor must be run with the circuit conductors and be connected to the equipment grounding terminal.

Electrical Connections for cabinets 77769, 77770, 81507, and 81508

Make sure that the power outlet voltage matches the voltage required by the machine. Refer to the specifications for equipment included with your system: ["Electrical Specifications" on page 20](#)

⚠ WARNING - Power Switch is the power disconnect device. Do not position the equipment such that access to the disconnect switch is impaired. If not readily accessible (such as within a rack or mounting out of reach), an additional disconnect device should be installed that can isolate the Live and Neutral lines of the mains power supply, whilst leaving the protective earth intact.

The following diagrams show the electrical connections.

["Wiring Diagram - sheet 1 of 10 \(120VAC\) - Power Distribution" on page 44](#)

["Wiring Diagram - sheet 3 of 10 \(230VAC\) - Power Distribution" on page 46](#)

Deco Reject Valve Pneumatic Diagram

This diagram shows the pneumatic valve connection to the 8-port I/O box.

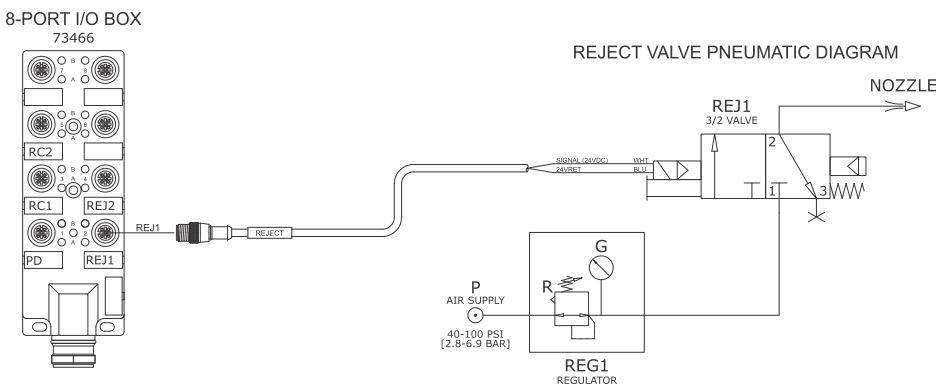

Commissioning

Before placing the machine into operation, make sure the following checks are completed:

Completed	Yes	No
Positioning and leveling of the unit		
Connection of compressed air line to connection points		
Connection of power supply to control enclosure		
Connection of power supply to inspection module(s) if applicable		
Proper wiring from the control enclosure to the inspection module using the wiring diagrams		

Chapter 6 Control Enclosure and Operator Interface Hardware

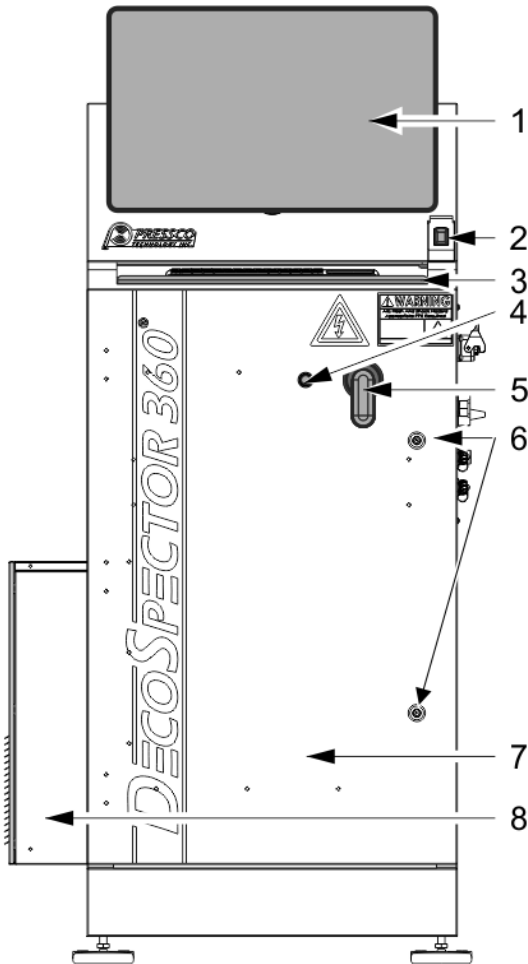

- 1) Touch screen monitor
- 2) Biometric login device
- 3) Keyboard tray
- 4) Power indicator LED
- 5) Power switch
- 6) Locks (Accessing the internal components with power OFF)
- 7) Vision processor (inside control enclosure)
- 8) Air conditioner

USB Ports

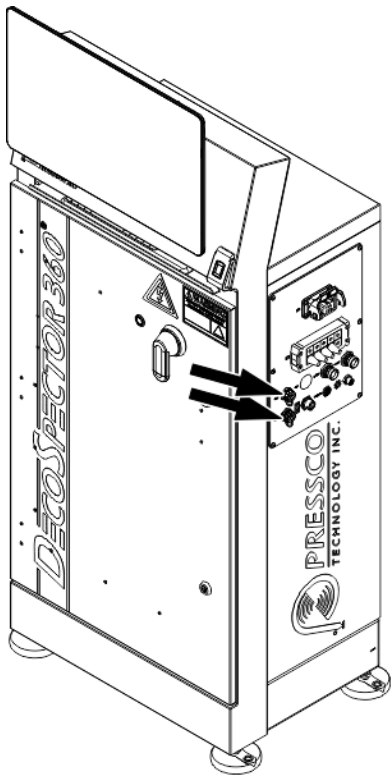

There are USB ports available to back up or transfer data.

Biometric Login Device

The Biometric Identification login device is used to log in and out of the Pressco system. This device is optional and must be purchased with the system.



To log in with this device, press your finger to the device. The following are conditions for use:

- You must use the same finger as initially set up by your administrator
- If you do not know how your account was set up (or which finger you used), contact your administrator
- If, after three tries, the Pressco does not recognize your finger print, you must log in using the On Screen Keyboard (OSK)

Power On and Off at the Control Enclosure

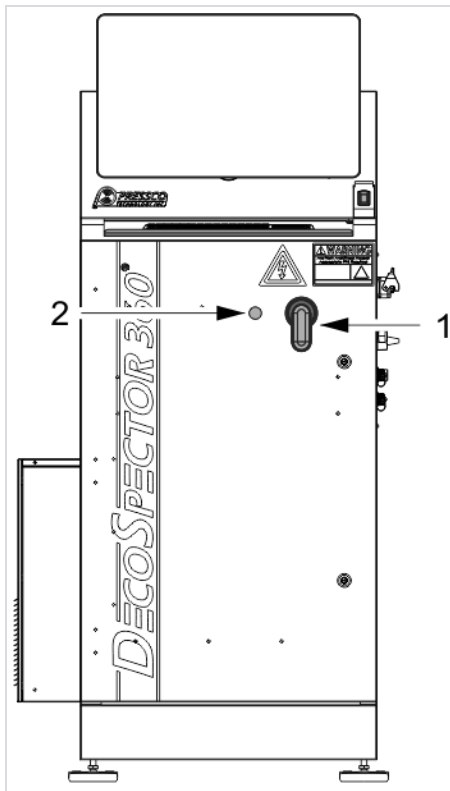

Power on: Turn on the switch [1] on the front of the cabinet. The power indicator [2] will illuminate. The software will start automatically. (You must log in and put the system online to begin inspection)

Note: it takes about a minute for the computer to start after the main power switch is turned ON

Power off: Turn off the switch on the front of the cabinet. The system, including the computer, shuts down. The UPS shuts down.

⚠ WARNING - When you shut down power using this switch, there is still voltage present on the UPS inside the unit until it discharges.

! Important - If you want to restart the system, turn off the power, let the software and components completely shut down, and leave the power off for about one minute before turning it back on. This allows the electronic components to correctly reset.

Accessing the Internal Components with Power Off

To access the components inside of the control cabinet, you will need the keys (supplied by Pressco).

⚠ WARNING - When the system is powered down, there is still voltage present at the UPS. Only **AUTHORIZED PERSONNEL** should attempt to open the system. We recommend that only **AUTHORIZED PERSONNEL** have access to the keys.

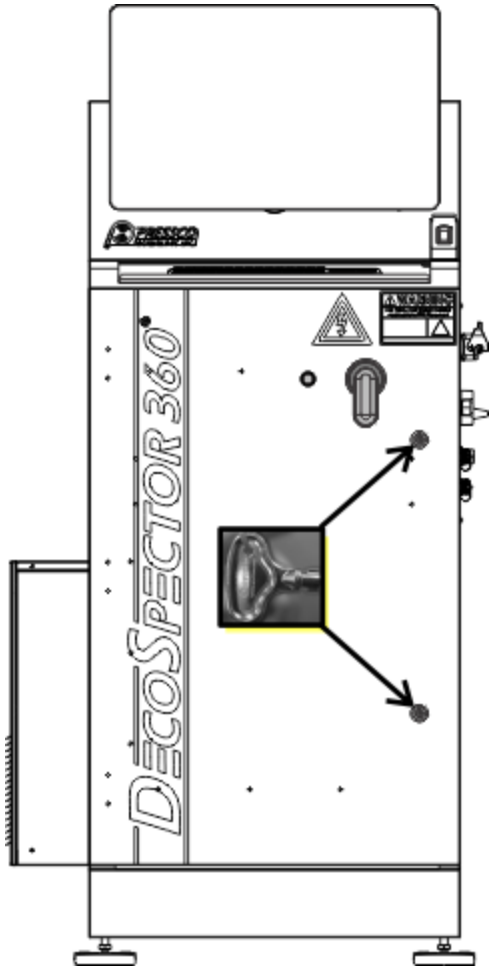

Lockout Procedure

To prevent power from being applied while the cabinet door is open:

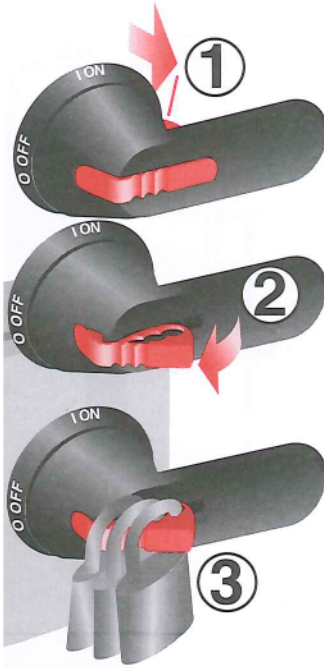

1. Make sure the handle is in the OFF position
2. Push the red piece of the handle out from the back
3. Secure up to three locks

Accessing the Internal Components with the Power On

The disconnect switch has an override feature allowing you to open the cabinet door while the switch is in the ON position.

⚠ WARNING - Only *AUTHORIZED SERVICE PERSONNEL* should access the inside of the computer while the power to the unit is still applied.

1. Use a small, blunt tool to press the small button on the left side of the handle. A 3/32" or 2.5mm allen key works best, but you can use a ball point pen.

⊘ Do not use a sharp tool to press the button.

2. Open the cabinet door.

⚡ Warning - live voltage is present within the cabinet.



Chapter 7 Components and Wiring Diagrams

Deco Interconnect Diagram

This diagram shows a typical DecoSpector 360™ system configuration. Blue Ethernet = Camera. Green = PDN.

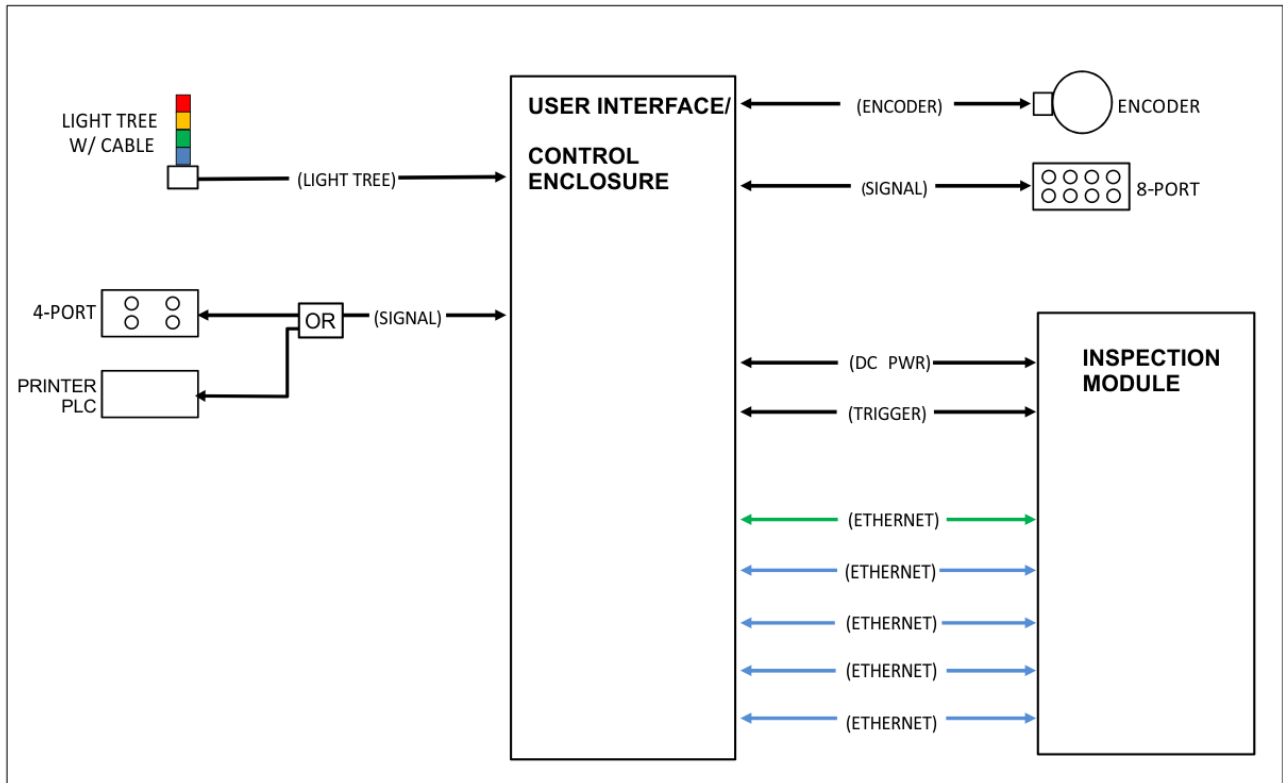

External Connections

The connectors are on the side of the DecoSpector cabinet.

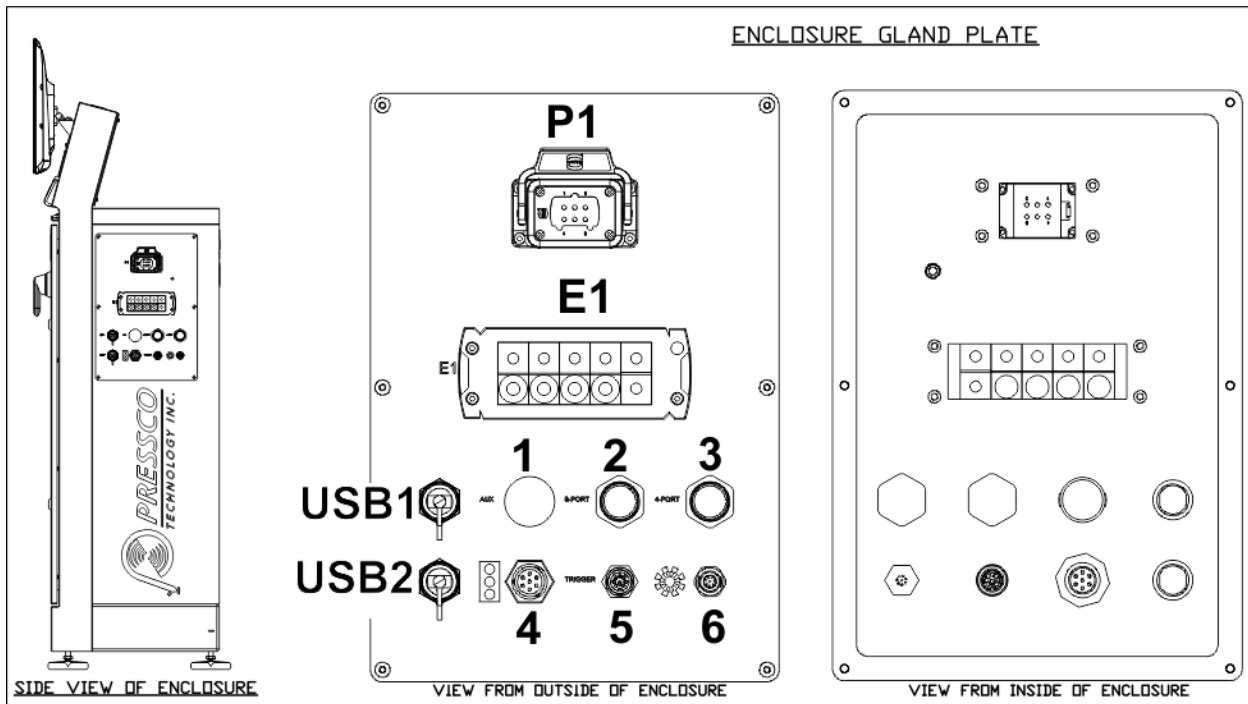

P1) Inspection Module power 12Vdc /24Vdc /48Vdc

E1) block connector - inspection module connections

USB1 and USB2 - for data transfer

- 1) Auxiliary input
- 2) 8-port I/O (part detection and rejection)
- 3) 4-port I/O (correlation sensors)
- 4) Light tree
- 5) Trigger (camera)
- 6) Encoder

Note: the connectors not called out in the diagram have no connection

Components Inside the Control Enclosure

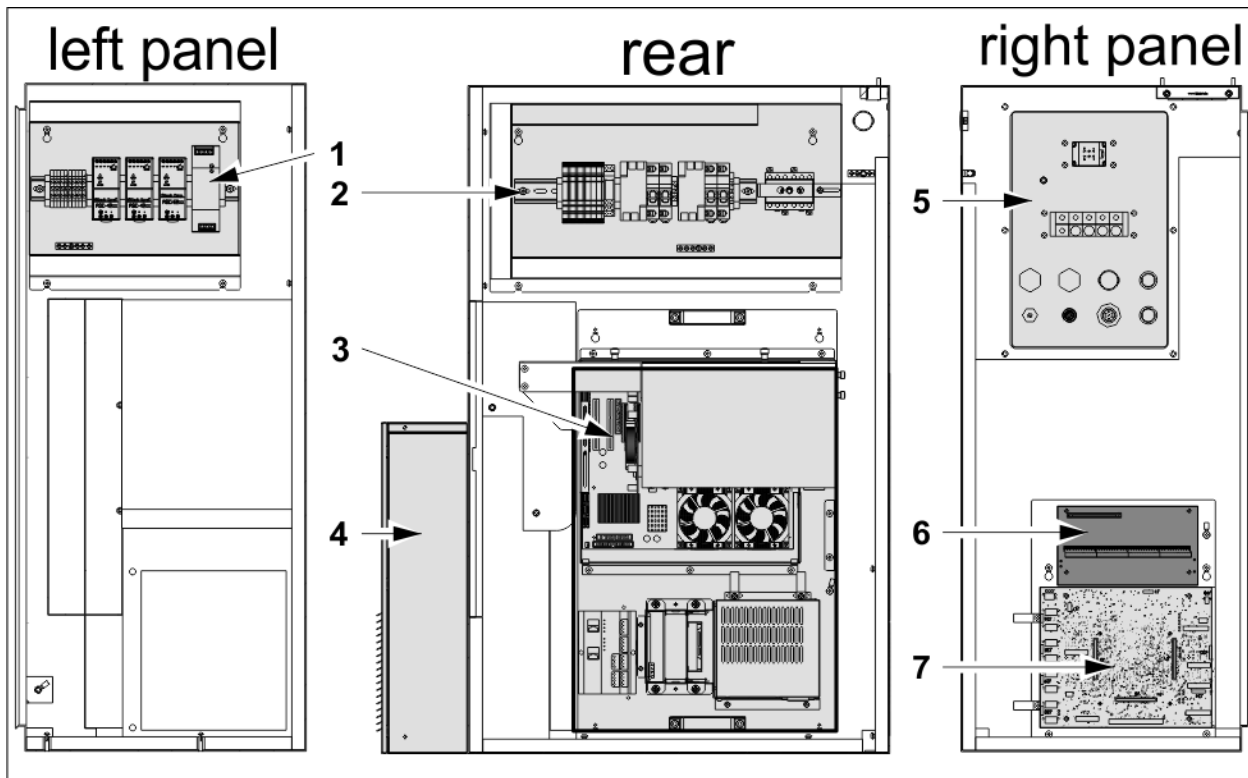

- 1) DC Power panel, TB2
- 2) Power Entry Panel, DISC1, TB1
- 3) Vision Processor Panel
- 4) Air conditioner
- 5) Gland plate
- 6) Extended I/O board
- 7) 8-channel part tracker board

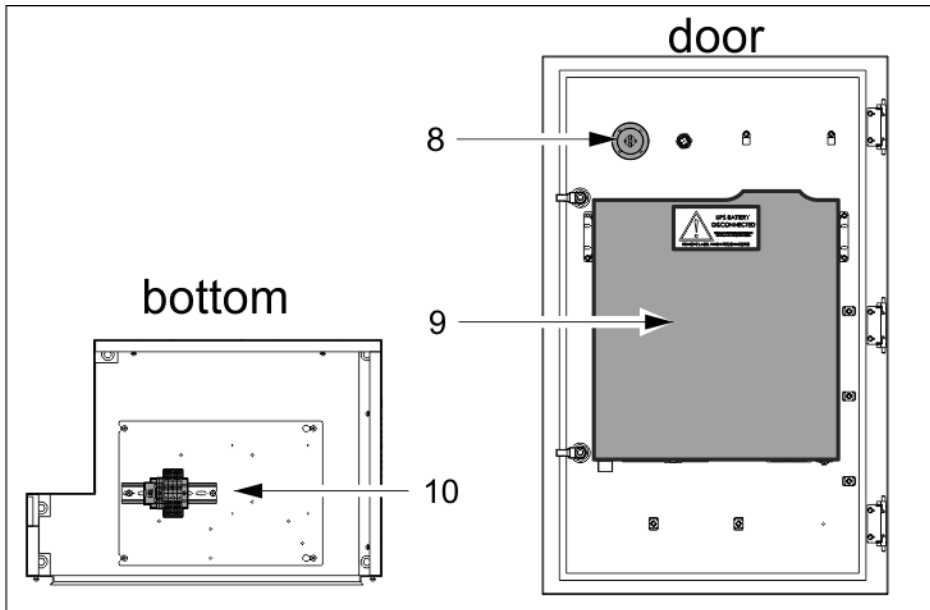

- 8) Power switch, DISC1 (connected by a rod to the disconnect on the rear of the cabinet)
- 9) UPS
- 10) PLC Correlation, Extended I/O Opto Relays 78746

Vision Processor Panel

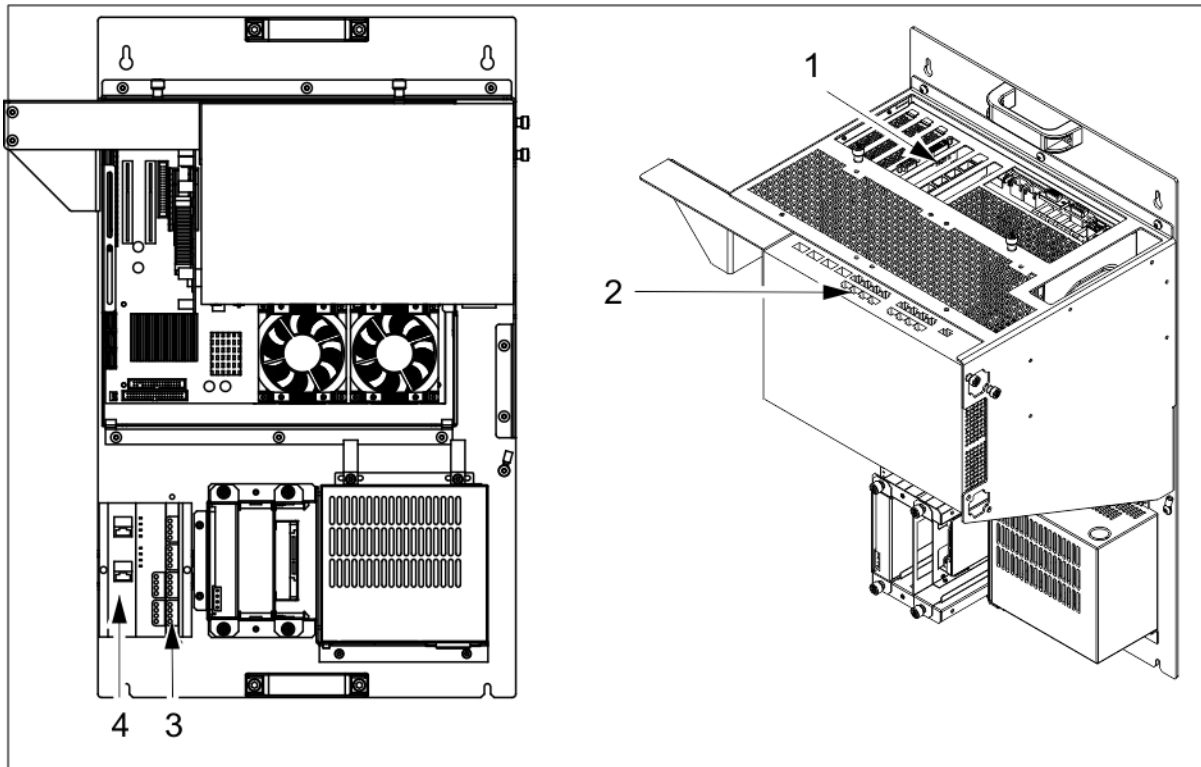

- 1) Vision Processor rear panel
- 2) Managed Ethernet switch
- 3) Remote I/O output module
- 4) Remote I/O coupler module

Fuse Replacement

! ***IMPORTANT:** Look at the fuse and replace it with the same size and rating as the fuse you are removing. The wiring diagrams may show a different size fuse than in your system.*

! ***WARNING -** For continued protection against fire hazard, replace fuses only with the same type and ratings. The use of other fuses or materials is prohibited.*

! ***WARNING -** Disconnect the product from the mains supply before replacing the fuse(s).*

For Fuse location, see Wiring Diagram - "[Wiring Diagram - sheet 5 of 10 - AC/DC Power Distribution](#)" on page 48

Purchase **Pressco Fuse kit 79649** for a set of replacement fuses for all types in the DecoSpector system.

Wiring Diagrams for Control Cabinet

See the next pages for the wiring diagrams for Pressco family documents F1904W, which are for the DecoSpector cabinet.

Wiring Diagram - sheet 1 of 10 (120VAC) - Power Distribution

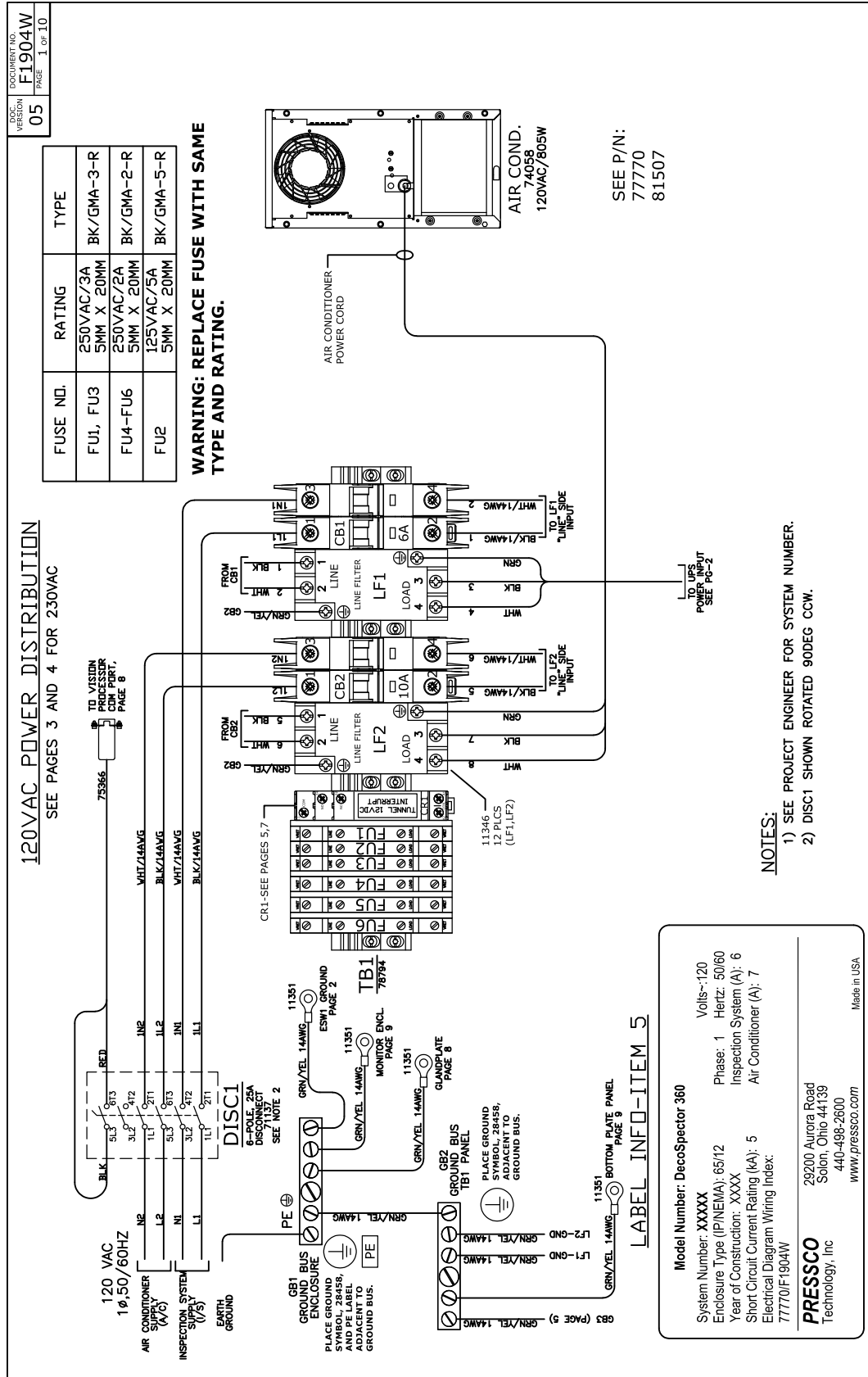

Wiring Diagram - sheet 2 of 10 (120VAC) - Power Distribution

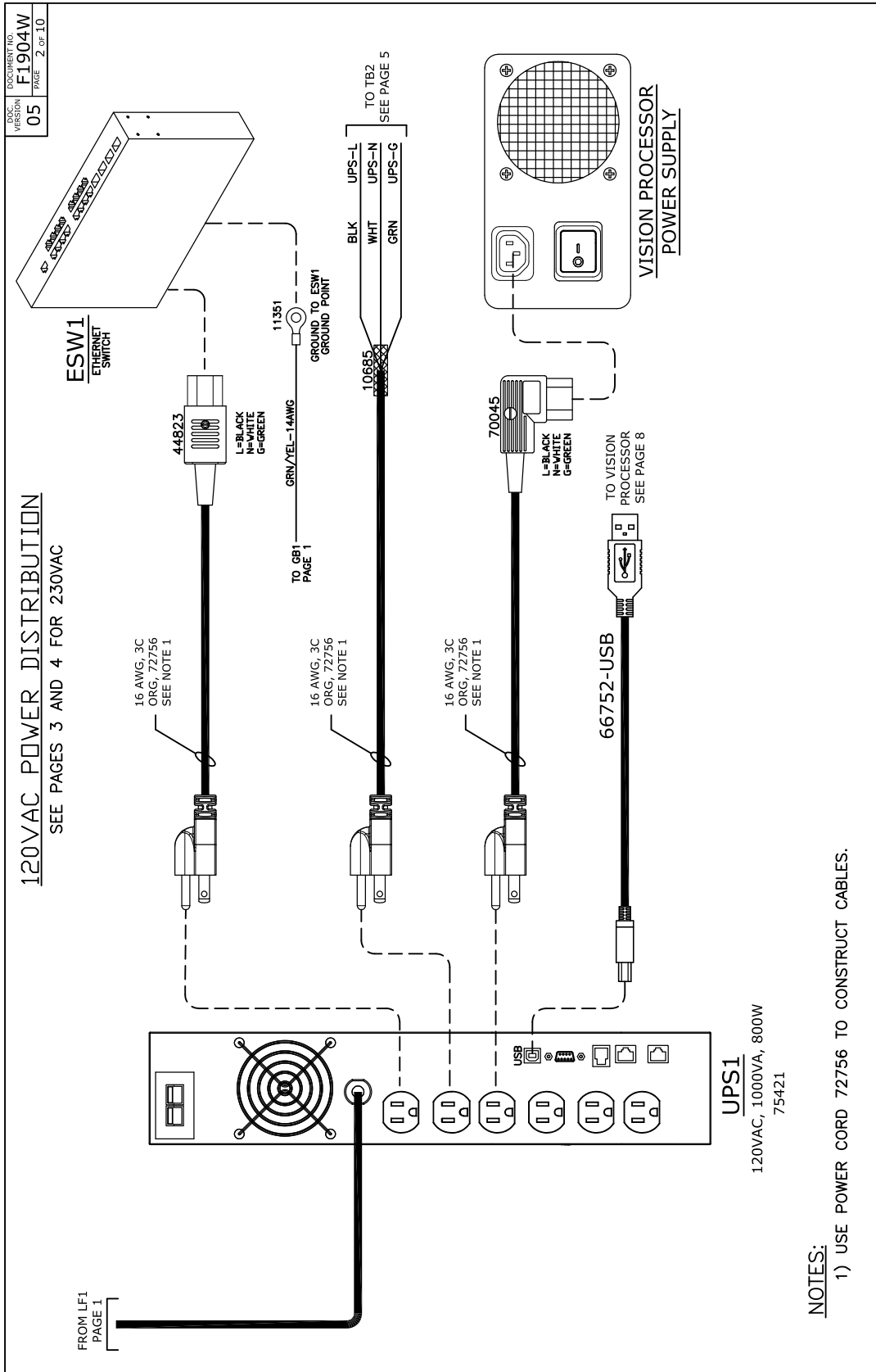

NOTES:

- 1) USE POWER CORD 72756 TO CONSTRUCT CABLES.

Wiring Diagram - sheet 3 of 10 (230VAC) - Power Distribution

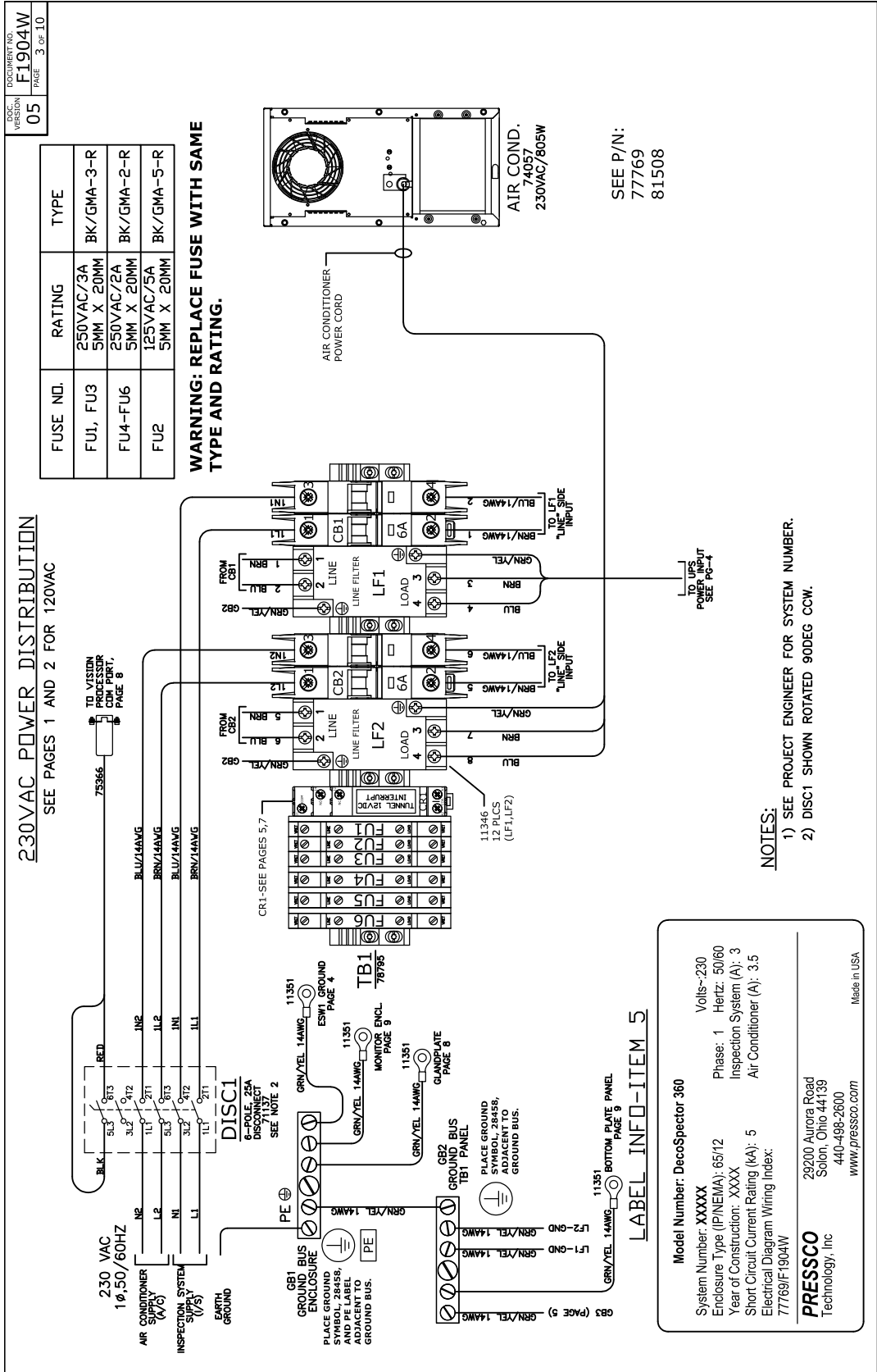

Wiring Diagram - sheet 4 of 10 (230VAC) - Power Distribution

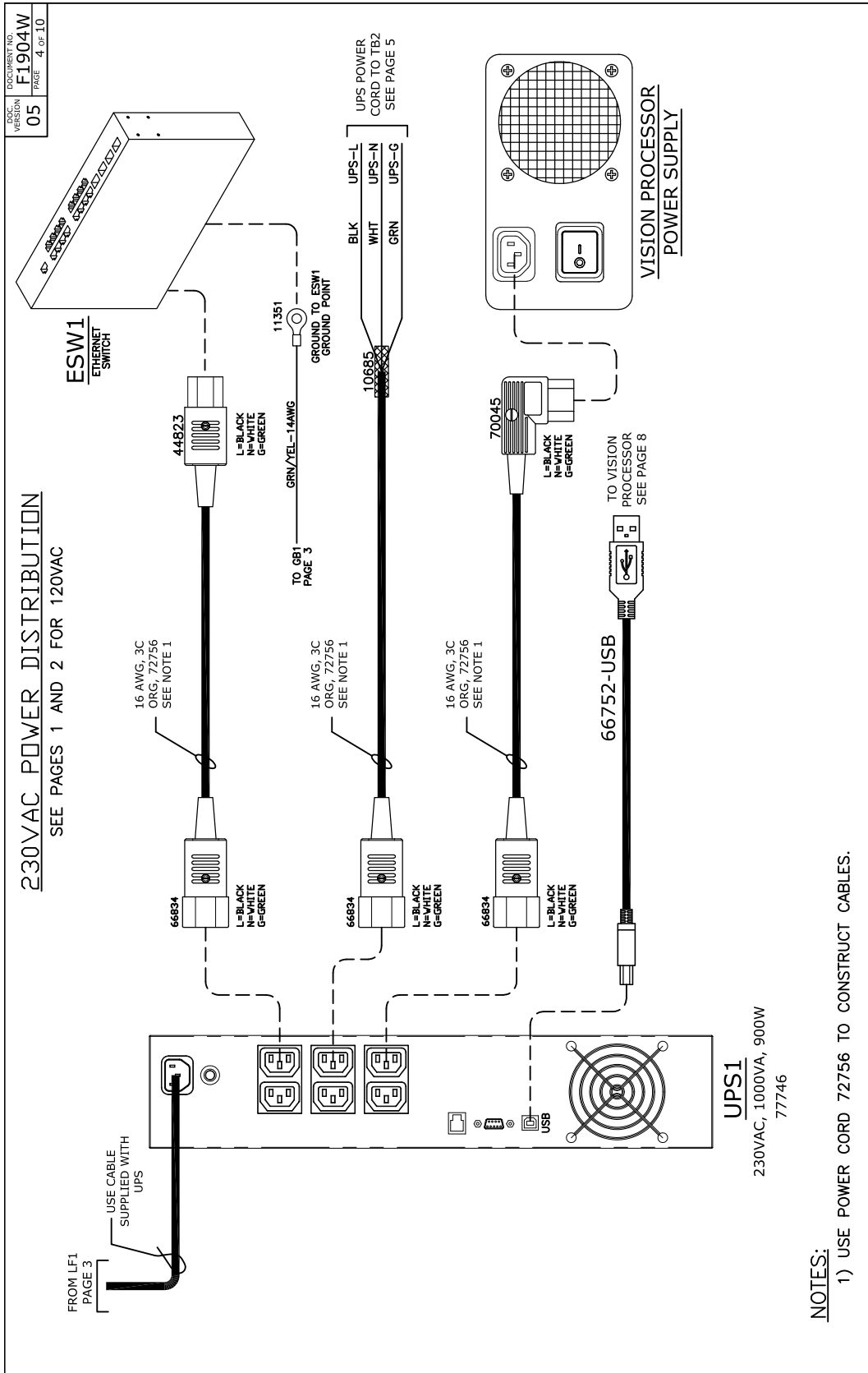

NOTES:

- 1) USE POWER CORD 72756 TO CONSTRUCT CABLES.

Wiring Diagram - sheet 6 of 10 - part tracker

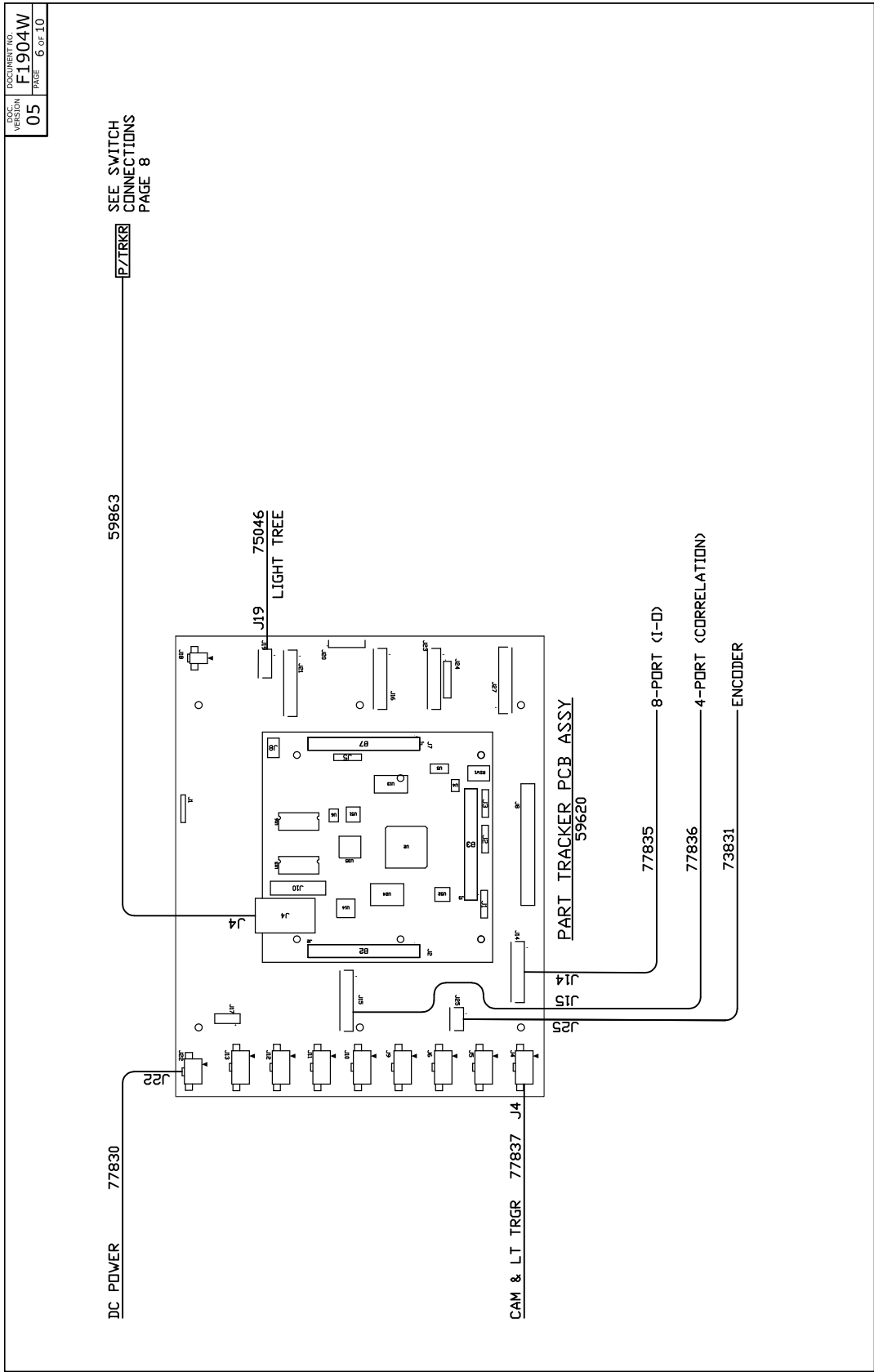

Wiring Diagram - sheet 7 of 10 - Extended I/O, Remote I/O

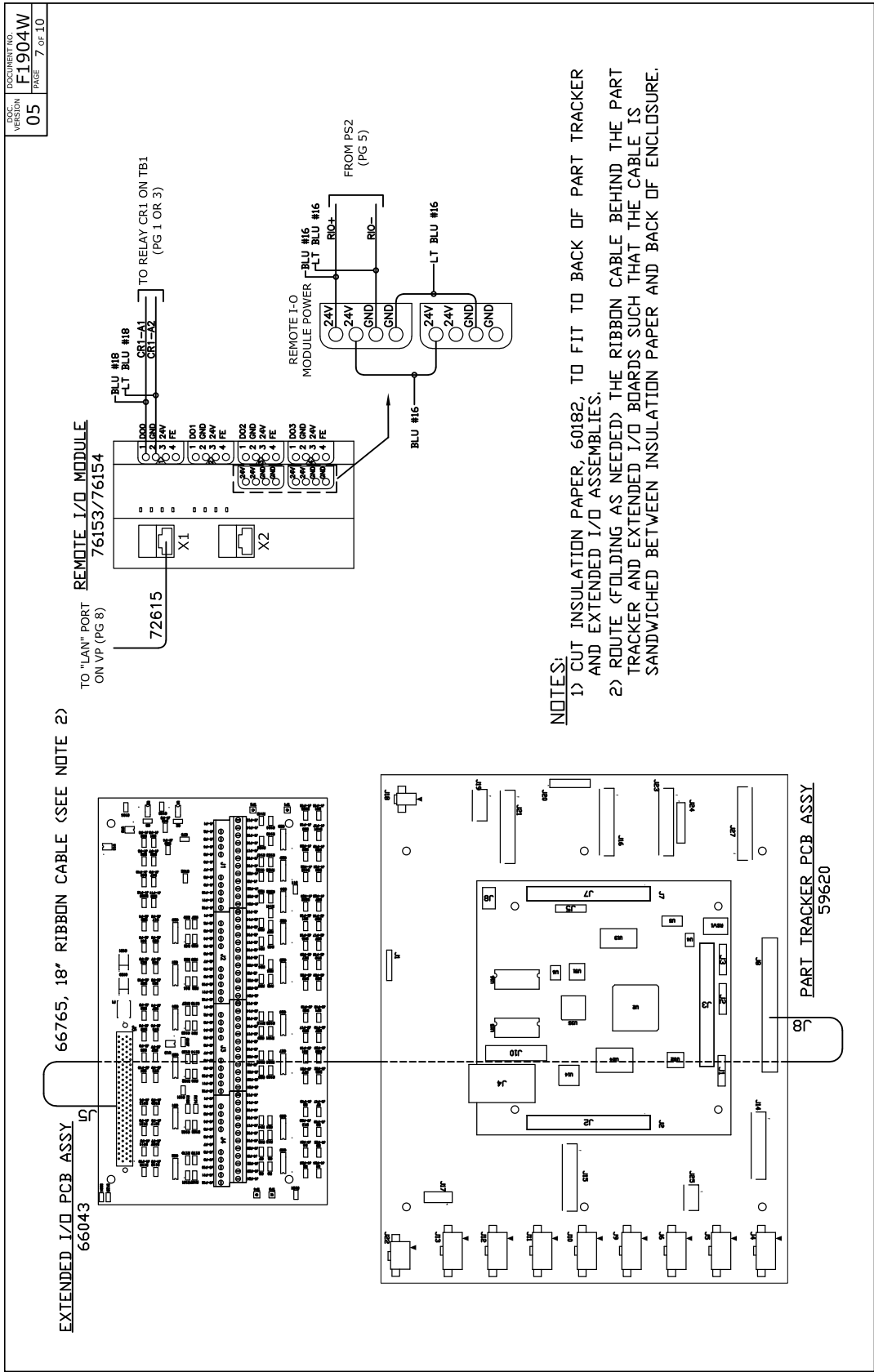

Wiring Diagram - sheet 8 of 10 - Vision Processor and Ethernet Switch

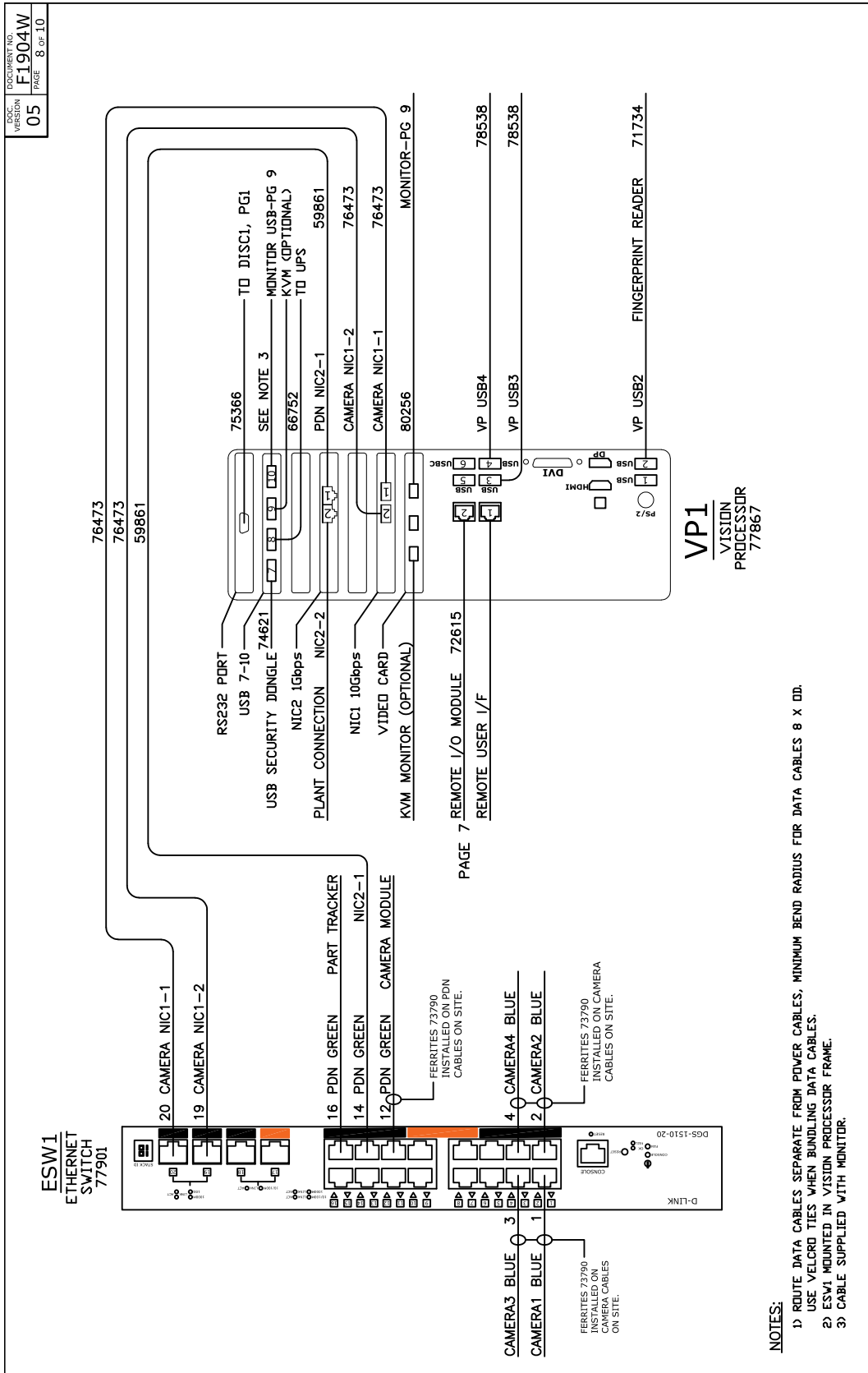

- NOTES:**
- 1) ROUTE DATA CABLES SEPARATE FROM POWER CABLES, MINIMUM BEND RADIUS FOR DATA CABLES 8 X DD.
 - 2) USE VELCRO TIES WHEN BUNDLING DATA CABLES.
 - 3) ESW1 MOUNTED IN VISION PROCESSOR FRAME.

Wiring Diagram - sheet 9 of 10 - monitor and 10-port phoenix block

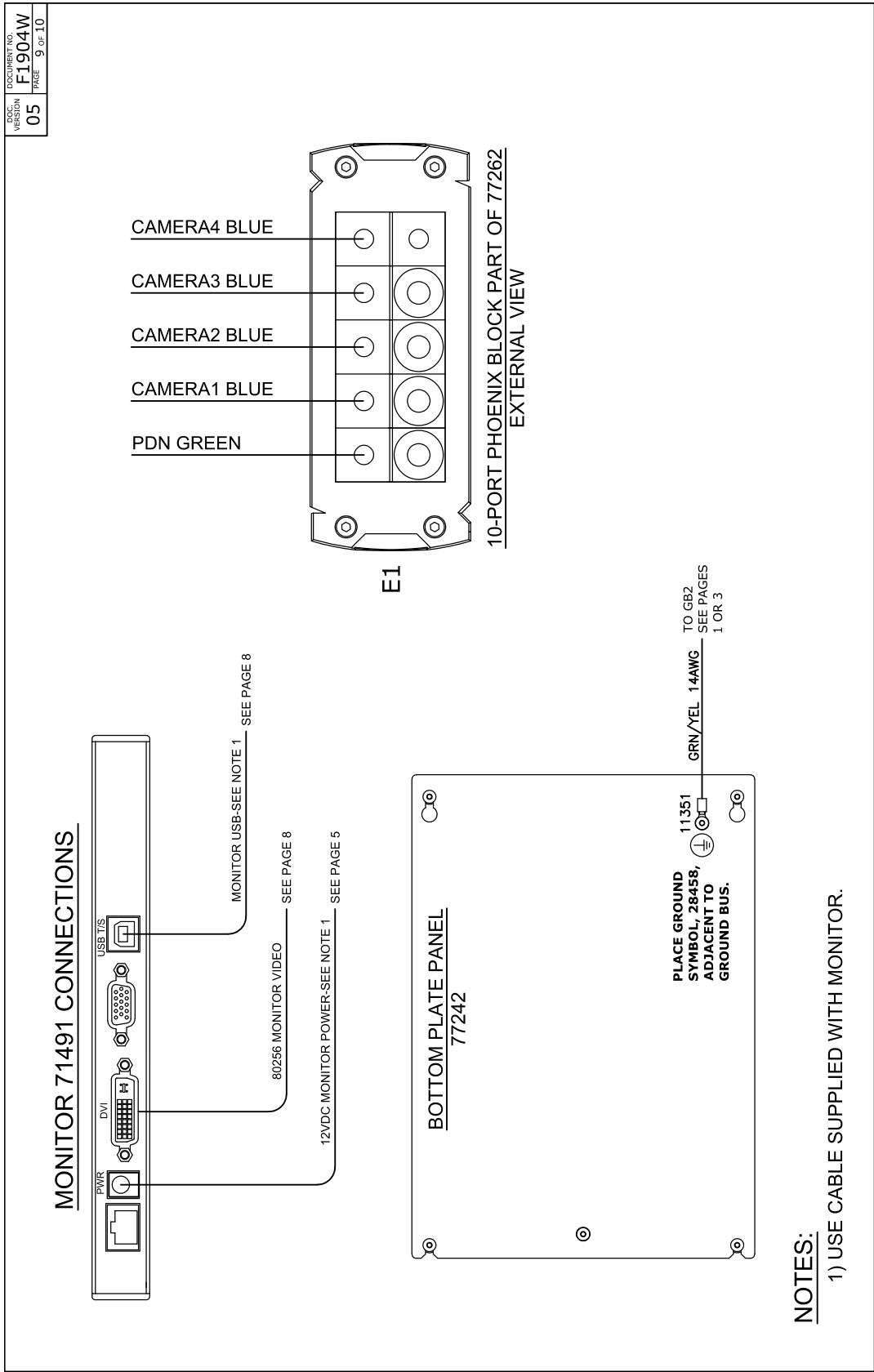

Wiring Diagram - sheet 10 of 10 - gland plate connections

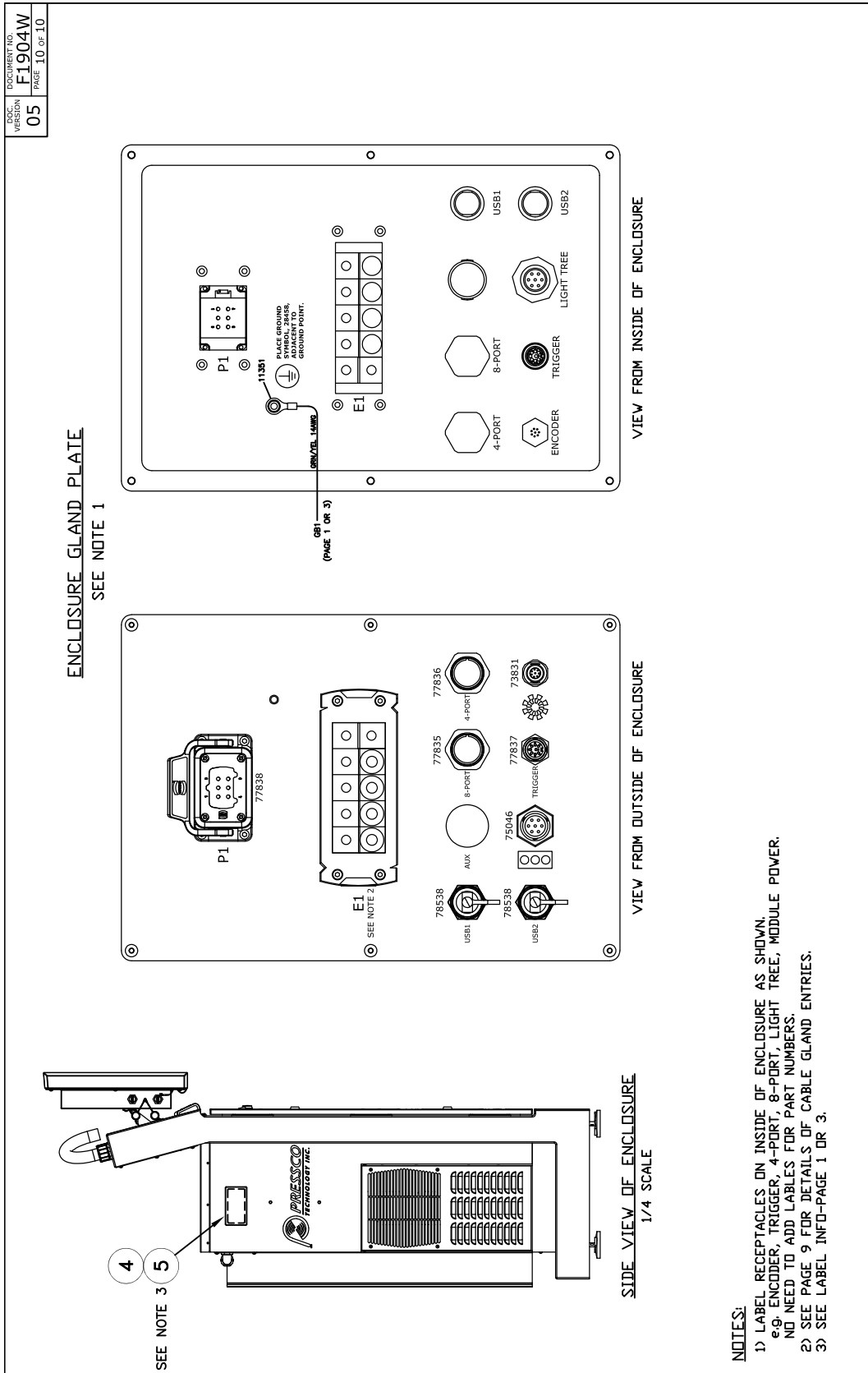

Wiring Diagrams for Inspection Modules

The wiring diagrams on the next several pages are for models DS6 - DS9 and XXL inspection modules. If your system has an earlier inspection module, contact Pressco for the wiring diagrams.

Wiring Diagram DS6 - 2 of 3

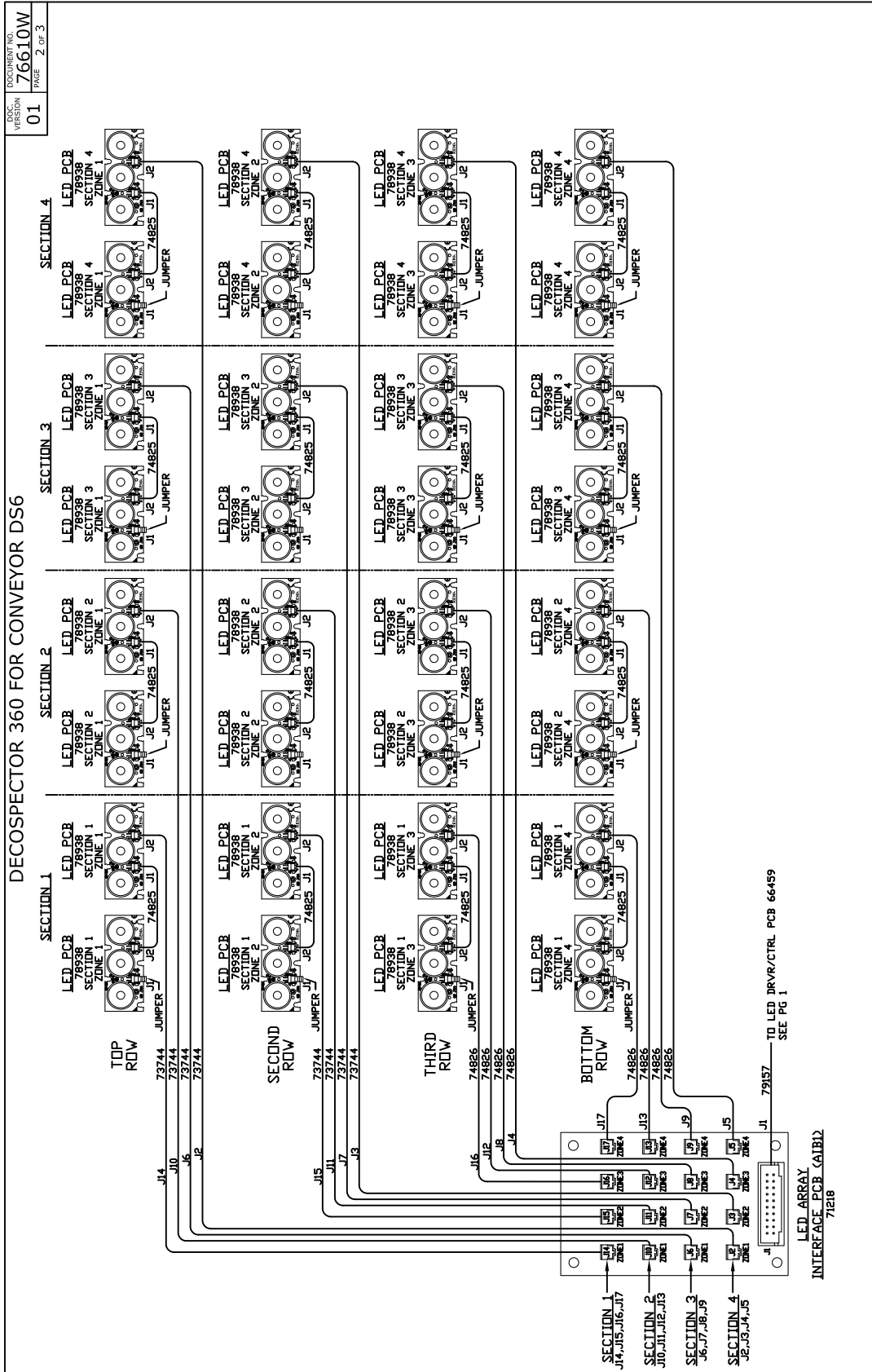

Wiring Diagram DS7 - 4 of 4

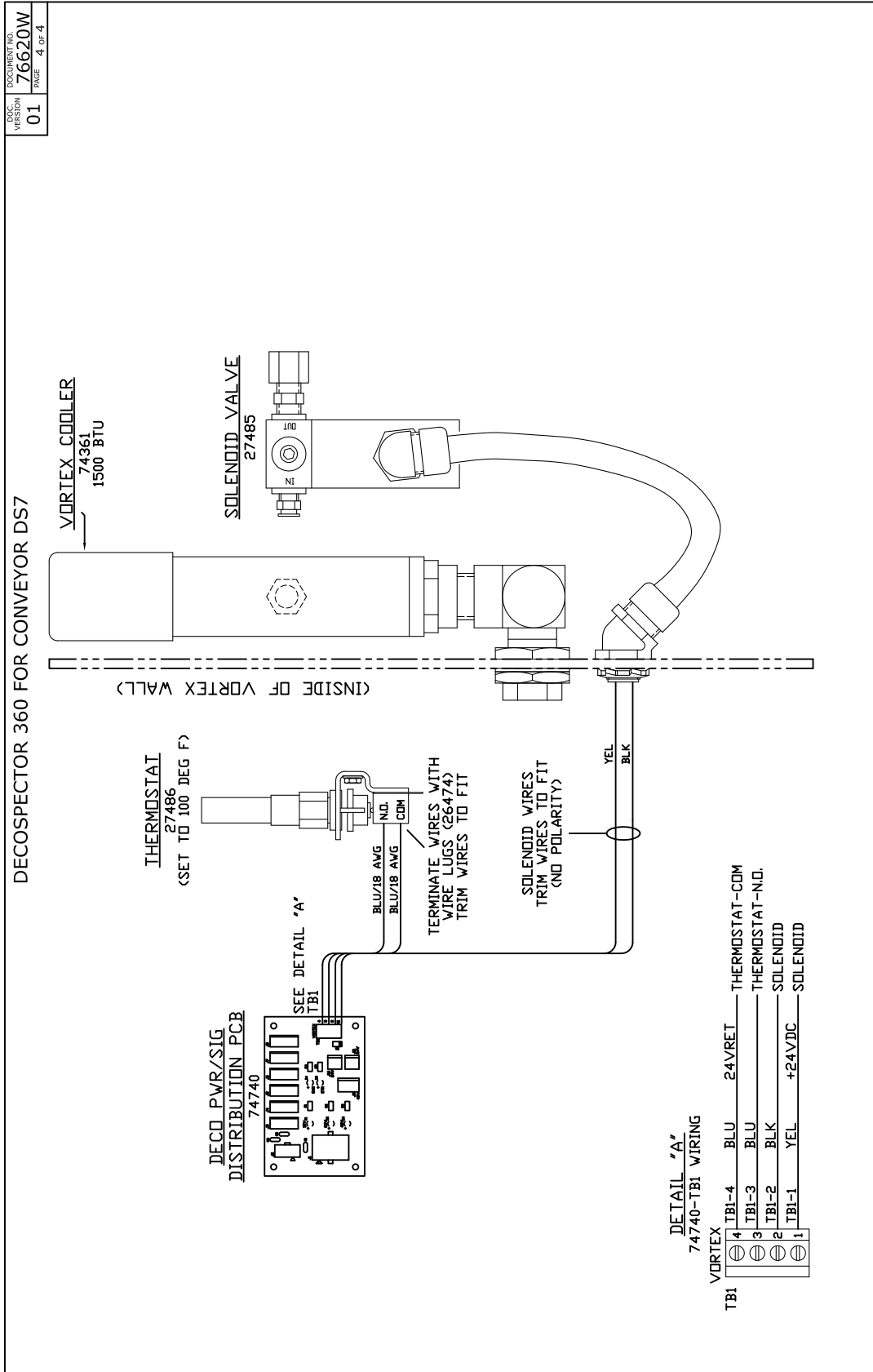

Wiring Diagram DS8 (model 80125W) - 1 of 3

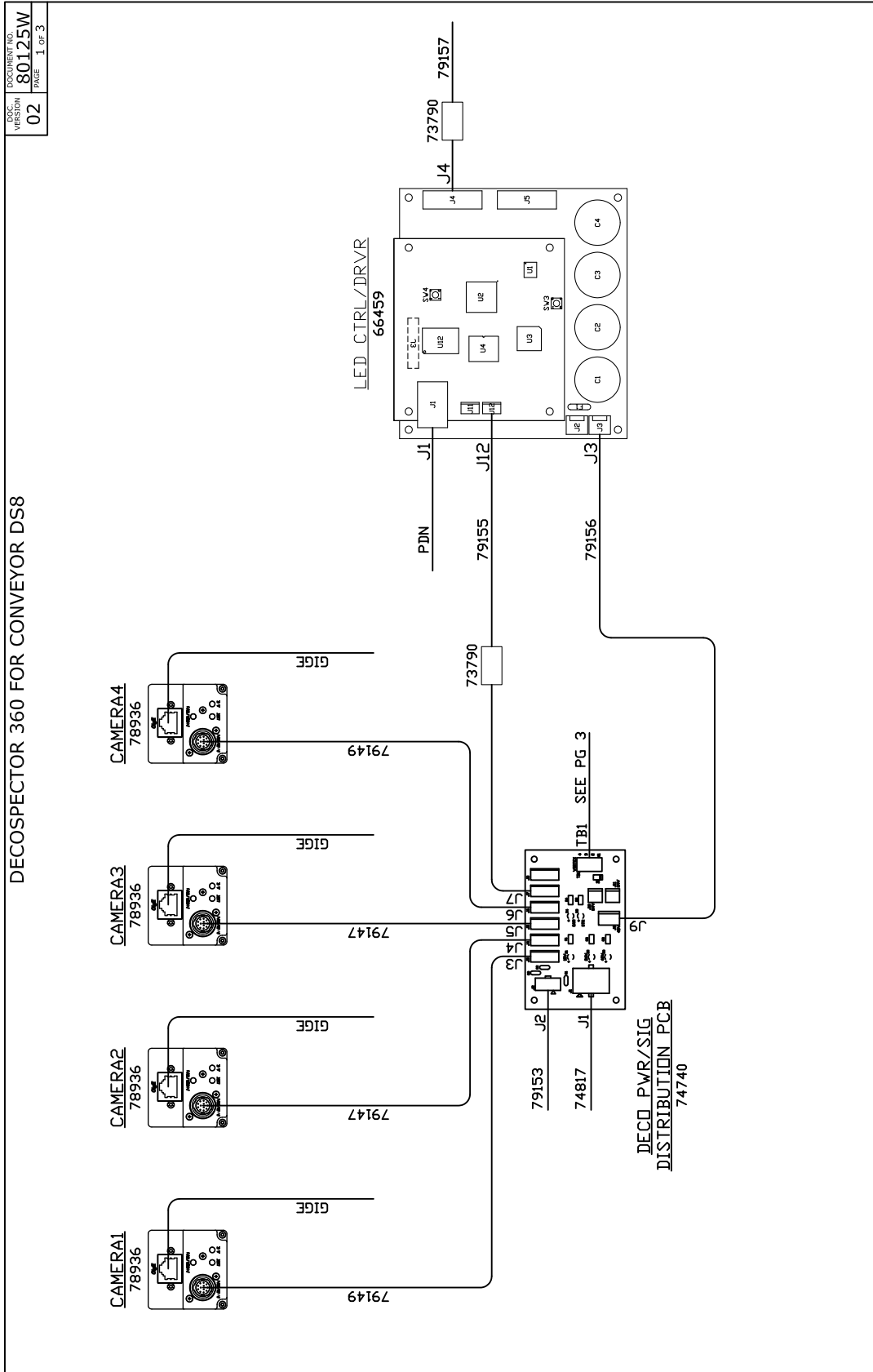

Wiring Diagram DS8 - 2 of 3

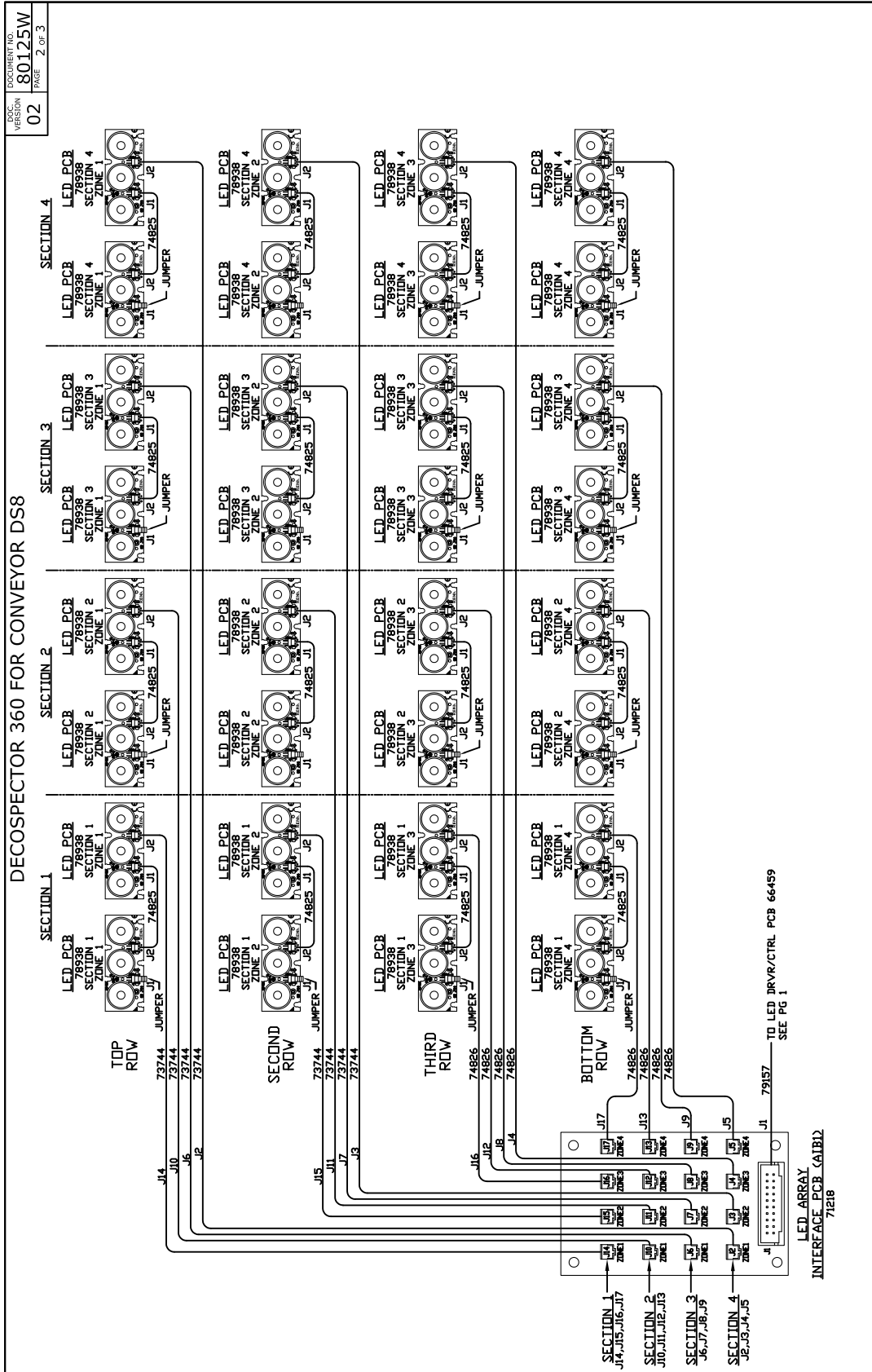

Wiring Diagram DS9 (model 80134W) - 1 of 4

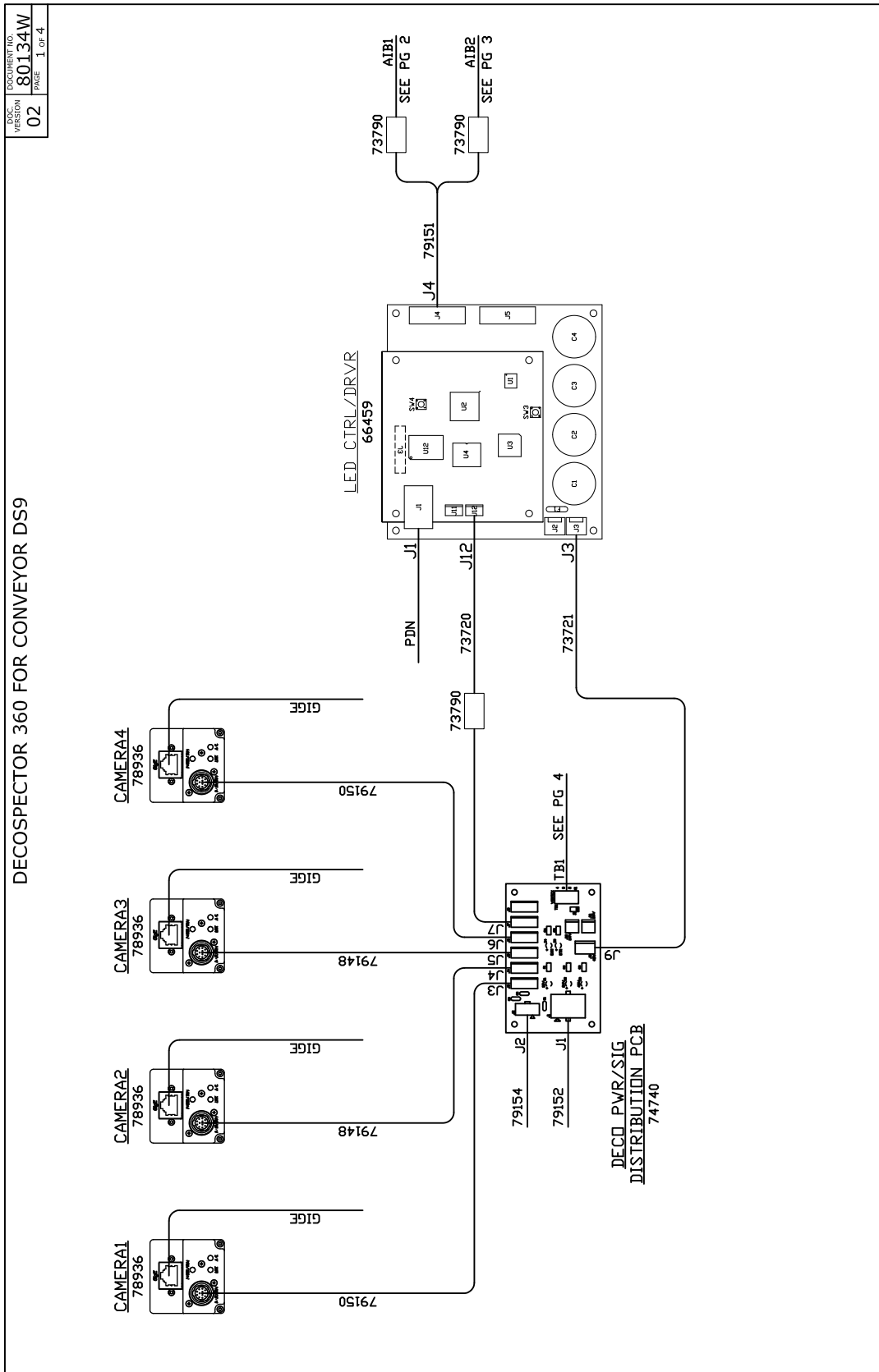

Wiring Diagram DS9 - 3 of 4

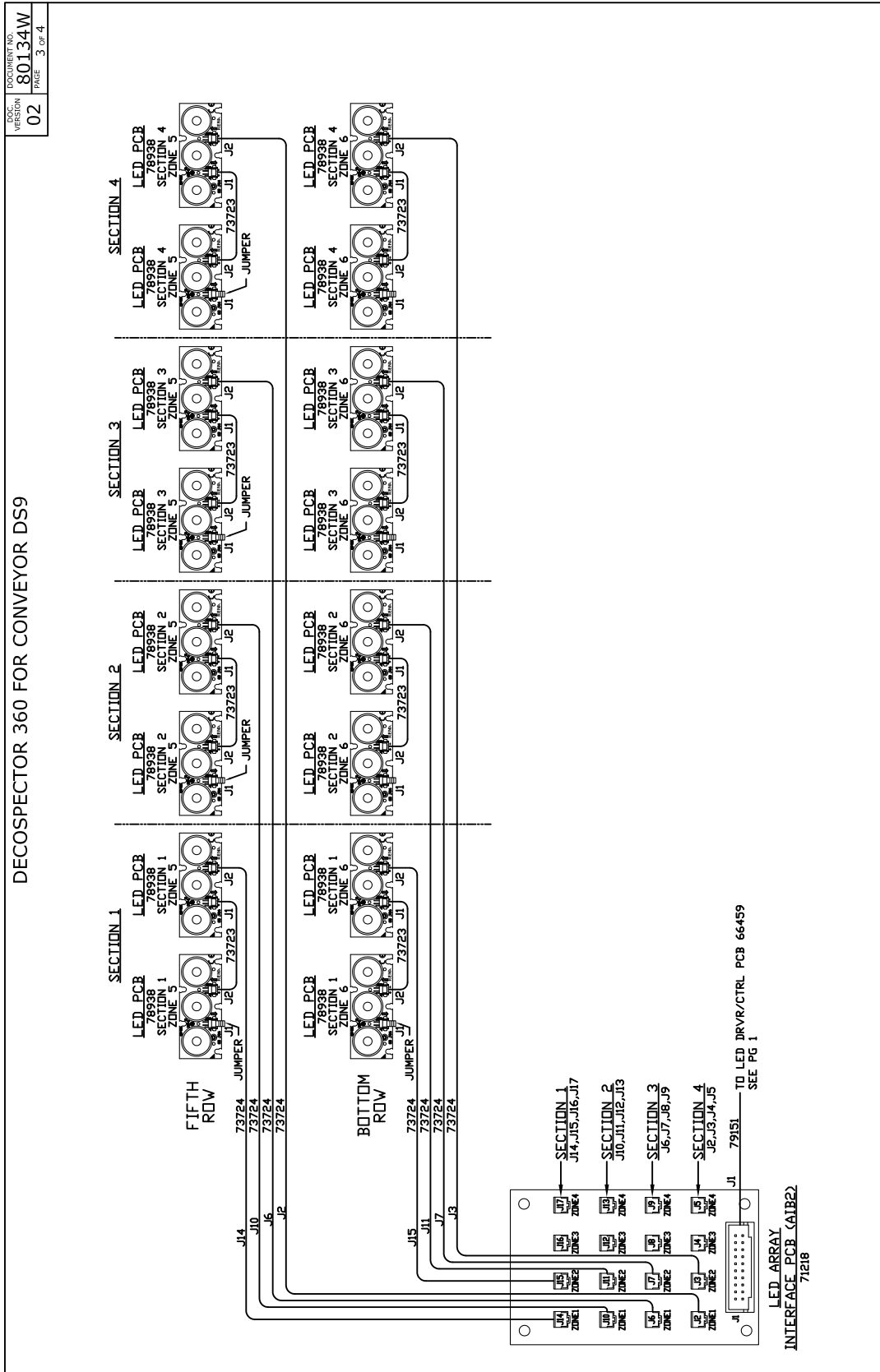

PLC Correlation, Extended I-O Opto Relays 78746 (Optional)

This terminal block (on the bottom of the cabinet) is where you connect the Extended I/O signals to your plant's PLC. Please see the Extended I/O section for wiring information.

Wiring with Relay Terminals marked 1, 2, 3, 4

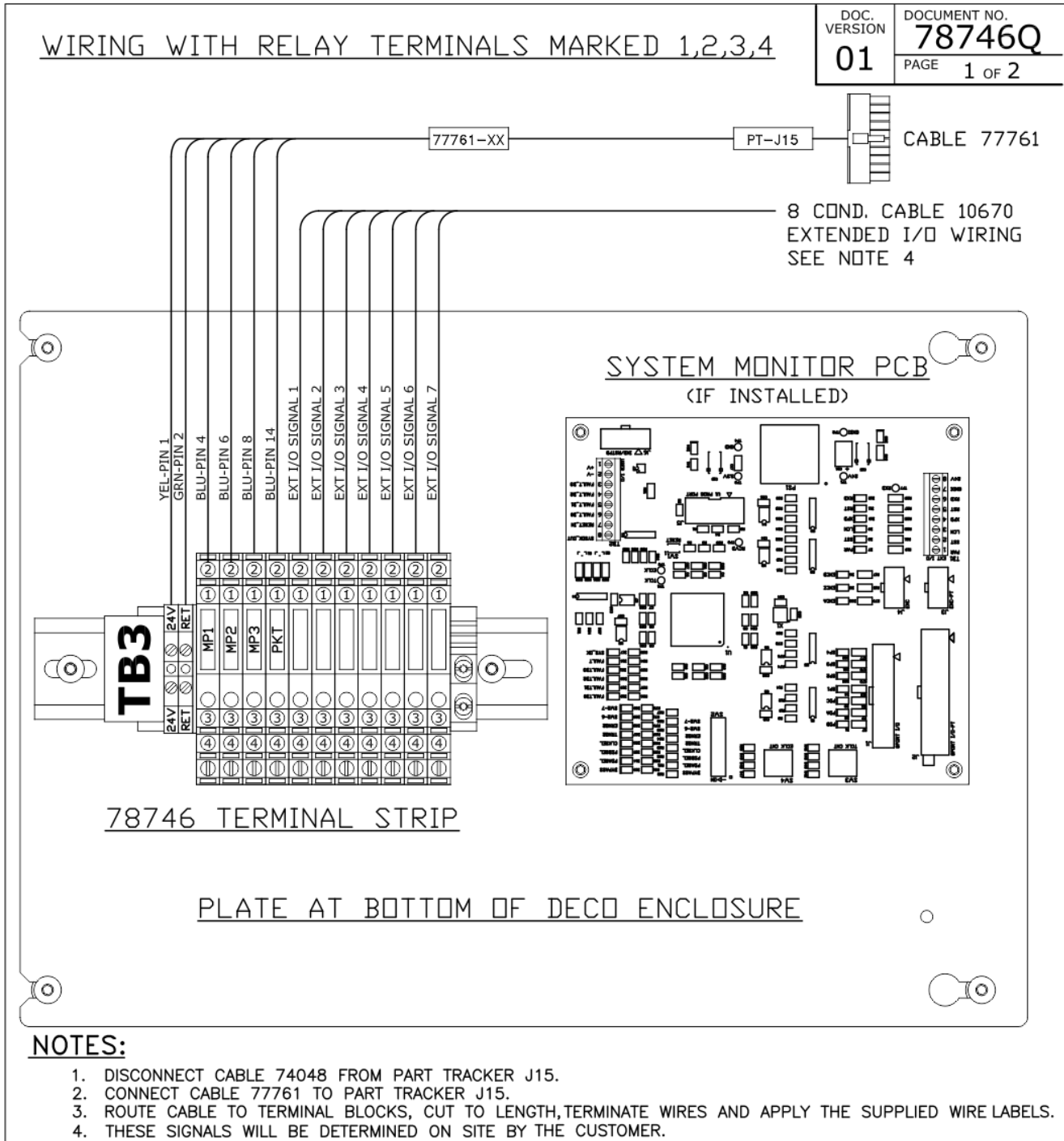

Wiring with Relay Terminals marked A1, A2, 13, 14

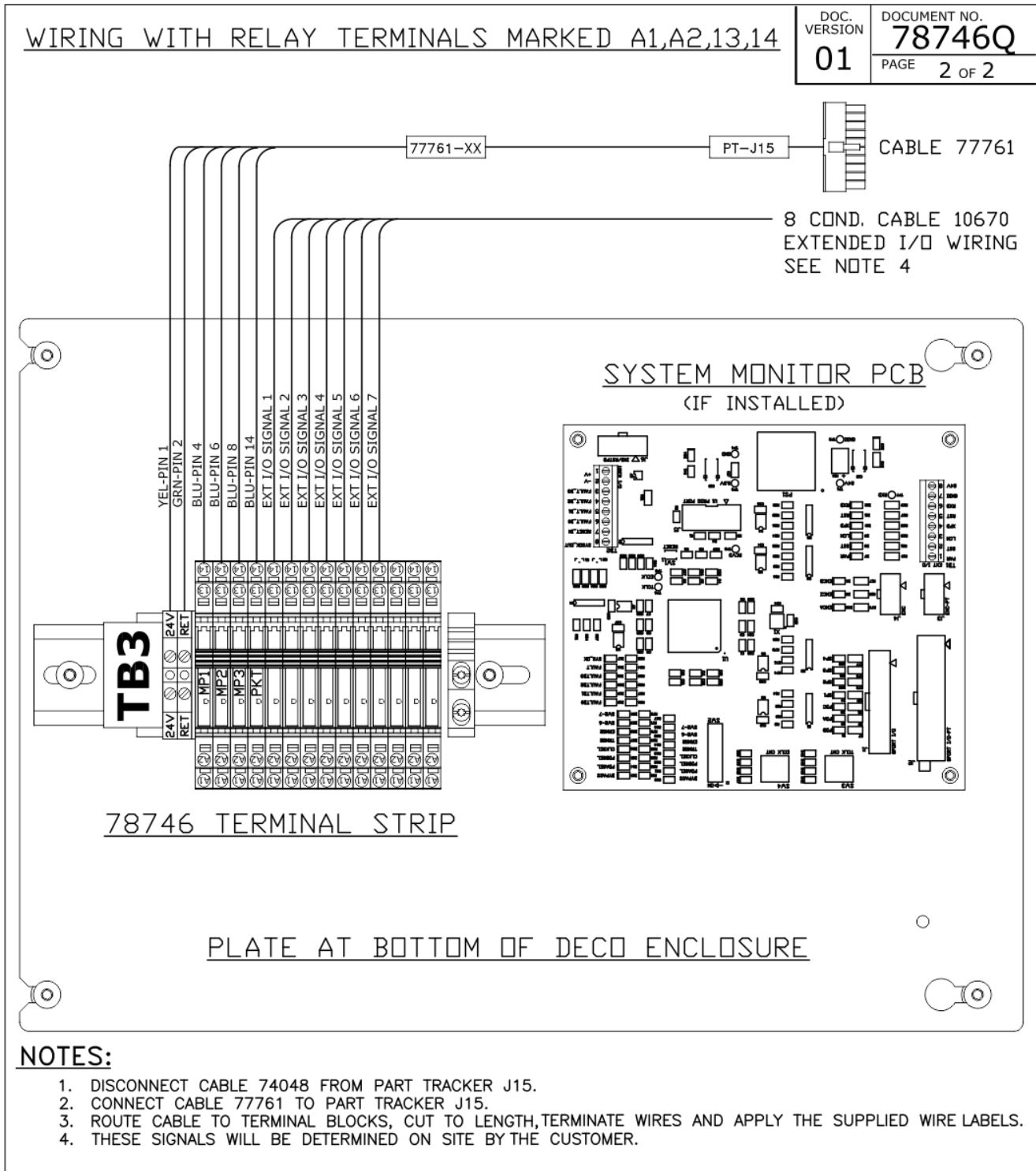

Wiring Diagram 78746 - 1 of 5

78746W Rev. 02. To see the available signals, see the section: "Deco Extended IO" on page 87.

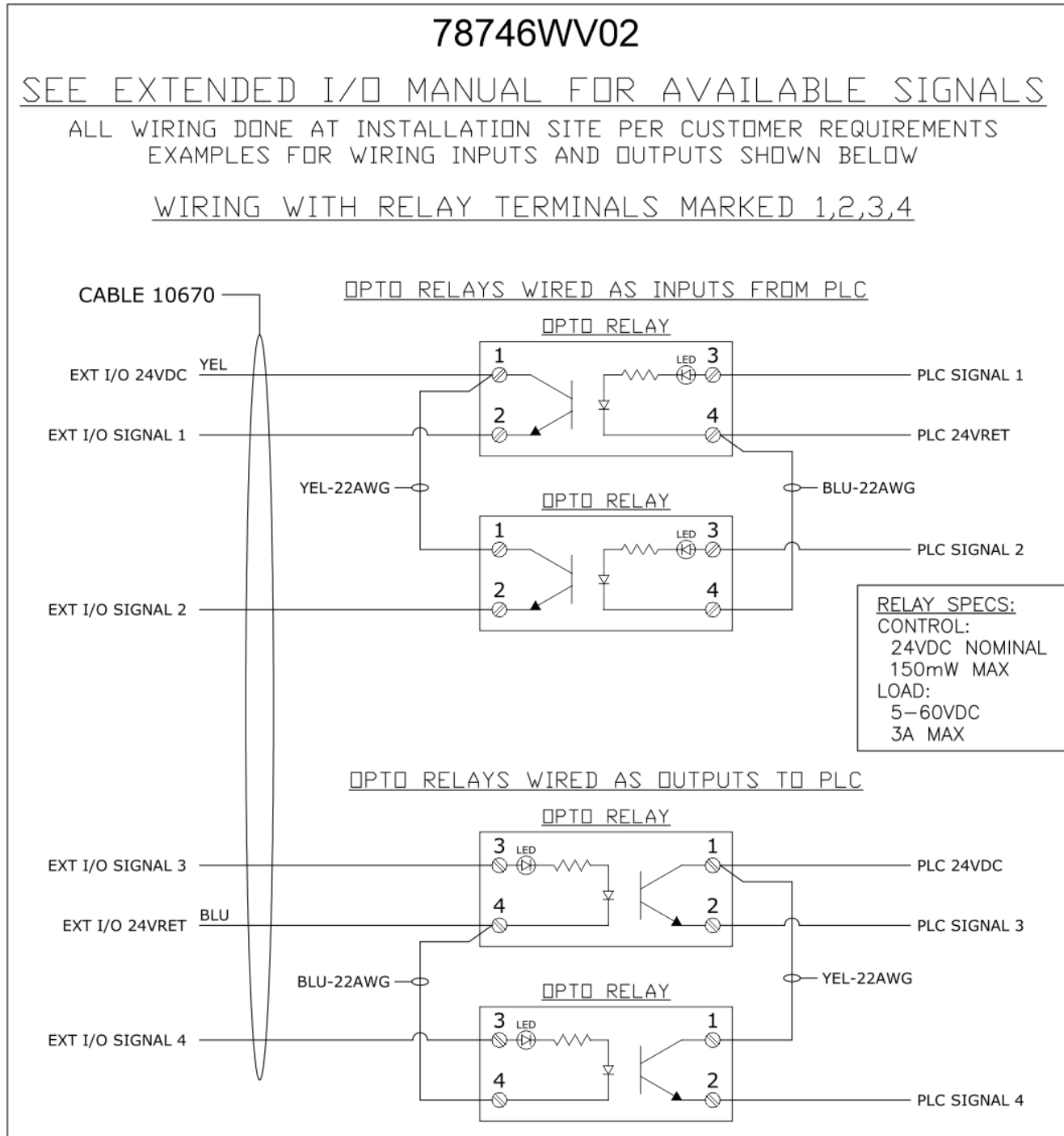

Wiring Diagram 78746 - 2 of 5

78746W Rev. 02. Opto relays wired for correlation inputs from PLC.

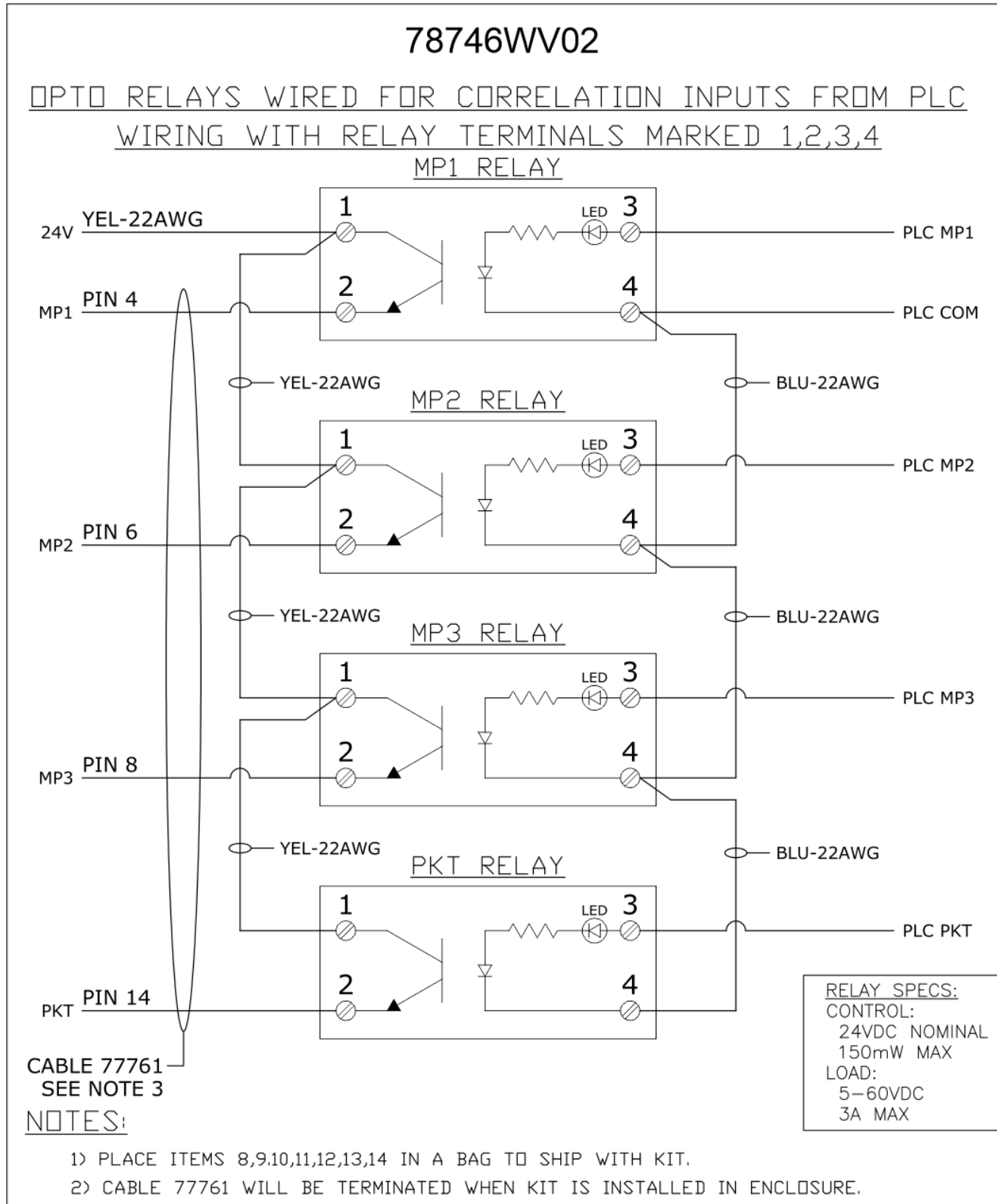

Wiring Diagram 78746 - 3 of 5

78746W Rev. 02. Examples for Opto Relays wiring per customer requirements.

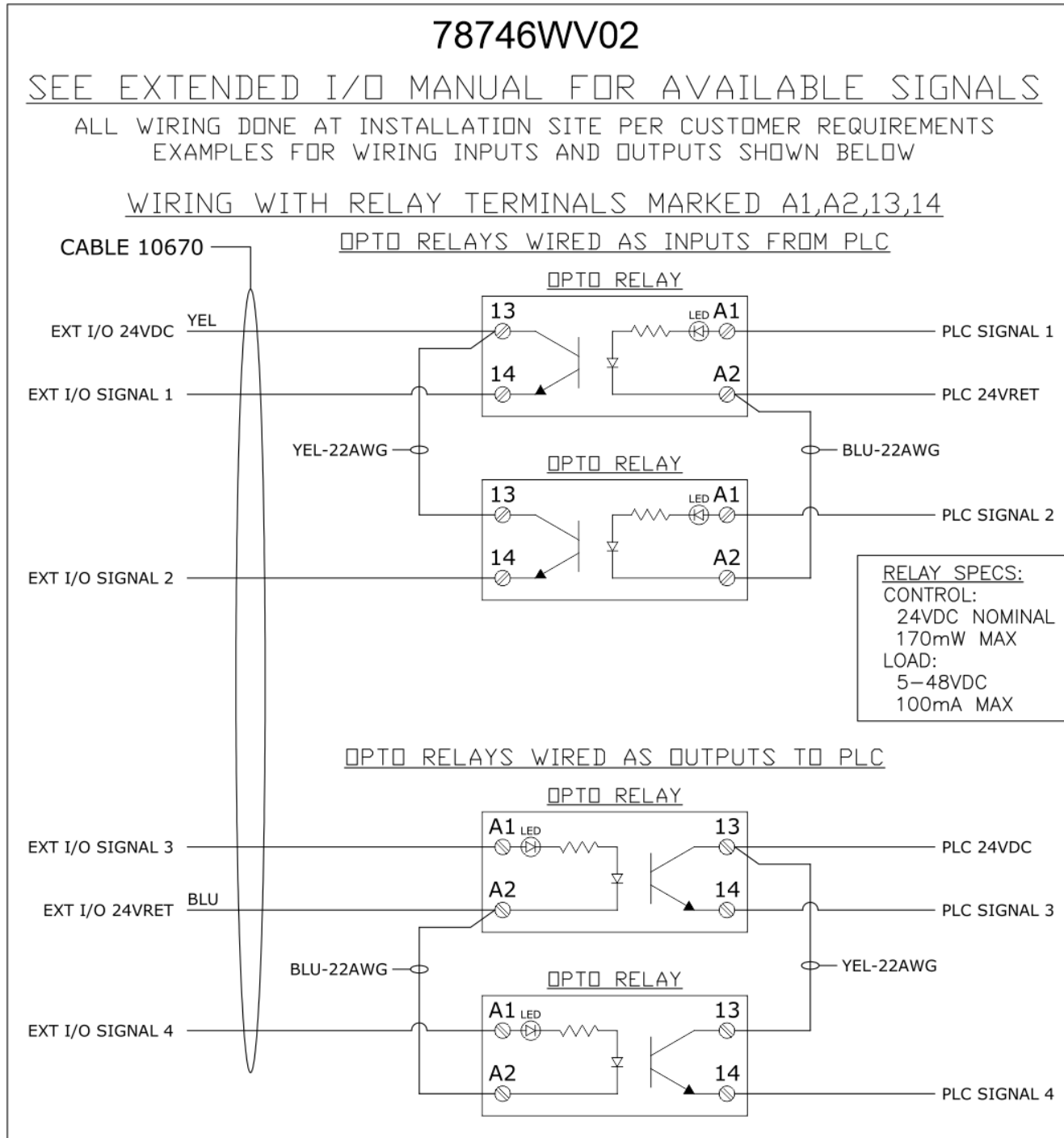

Wiring Diagram 78746 - 4 of 5

78746W Rev. 02. Opto Relays wired for correlation inputs from PLC.

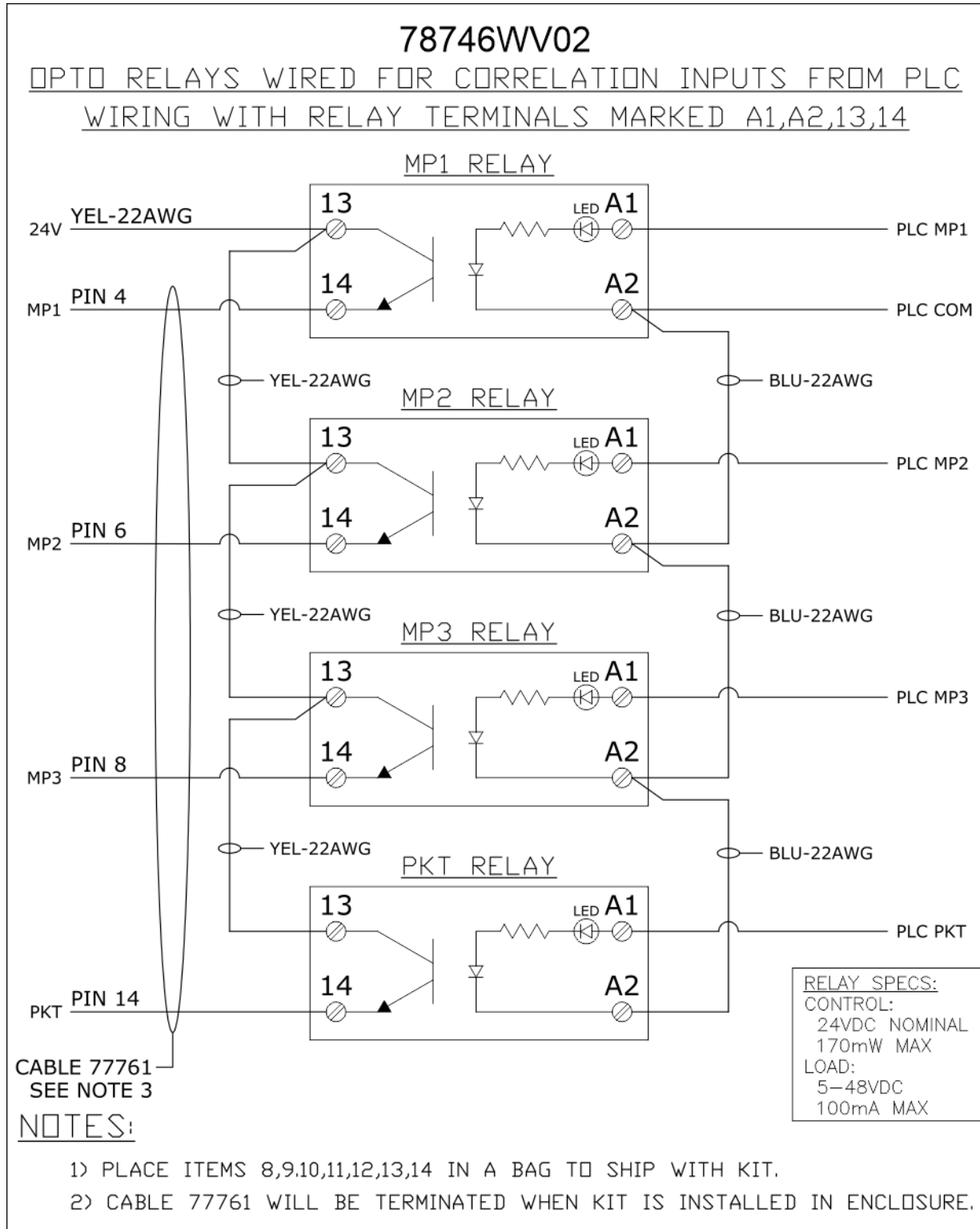

Wiring Diagram 78746 - 5 of 5

78746W Rev. 02. TB3.

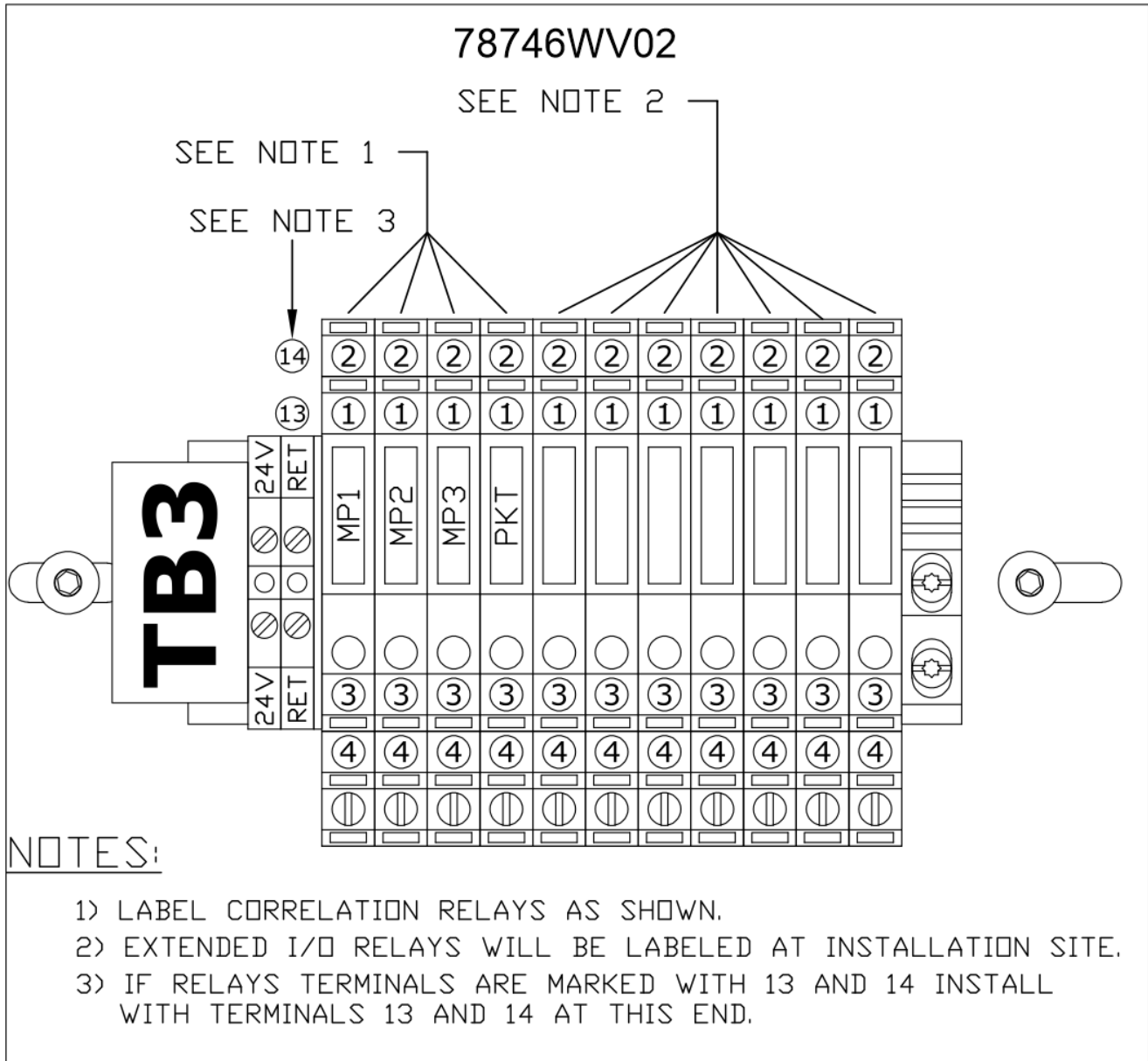

PLC Correlation Opto Relays 78257 (Optional)

This terminal block (on the bottom of the cabinet) is where you connect the Extended I/O signals to your plant's PLC. Please see the Extended I/O section for wiring information.

The difference between this kit (78257) and kit 78746 is that 78746 provides additional relays for the PLC to interface with the Extended I/O signals.

Wiring with Relay Terminals marked 1, 2, 3, 4

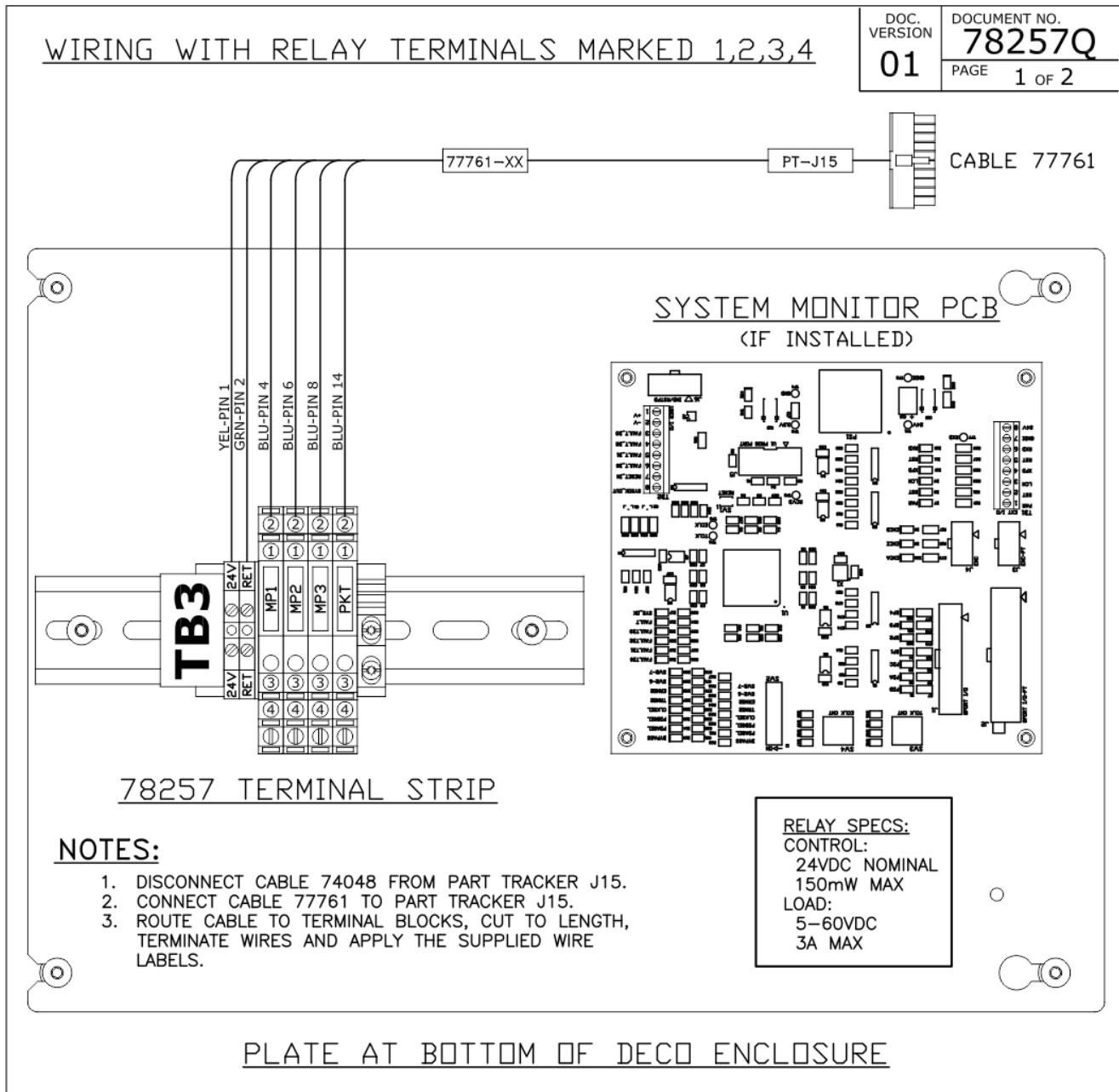

Wiring with Relay Terminals marked A1, A2, 13, 14

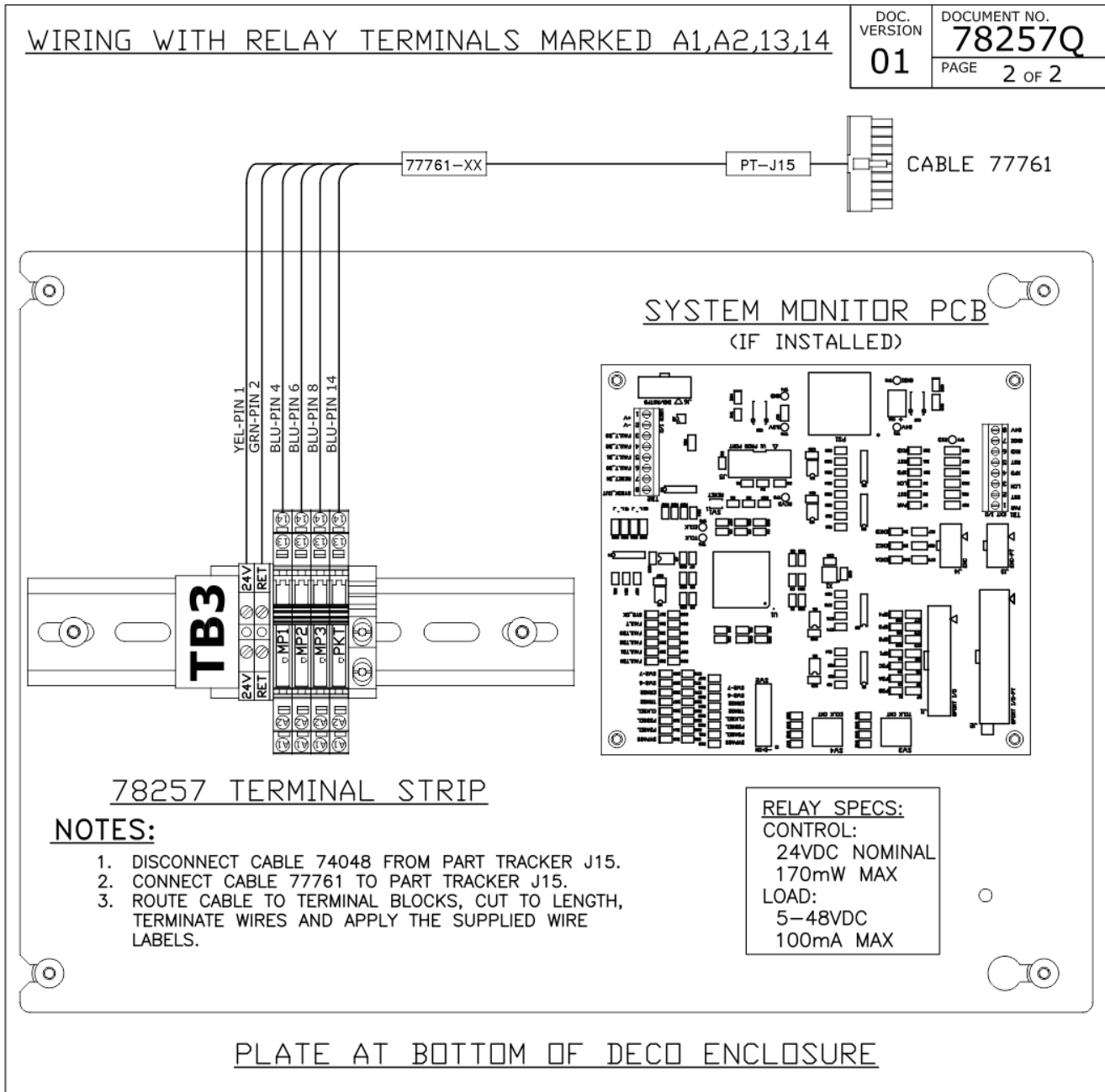

Wiring Diagram 78257 - 1 of 3 (relay terminals marked 1,2,3,4)

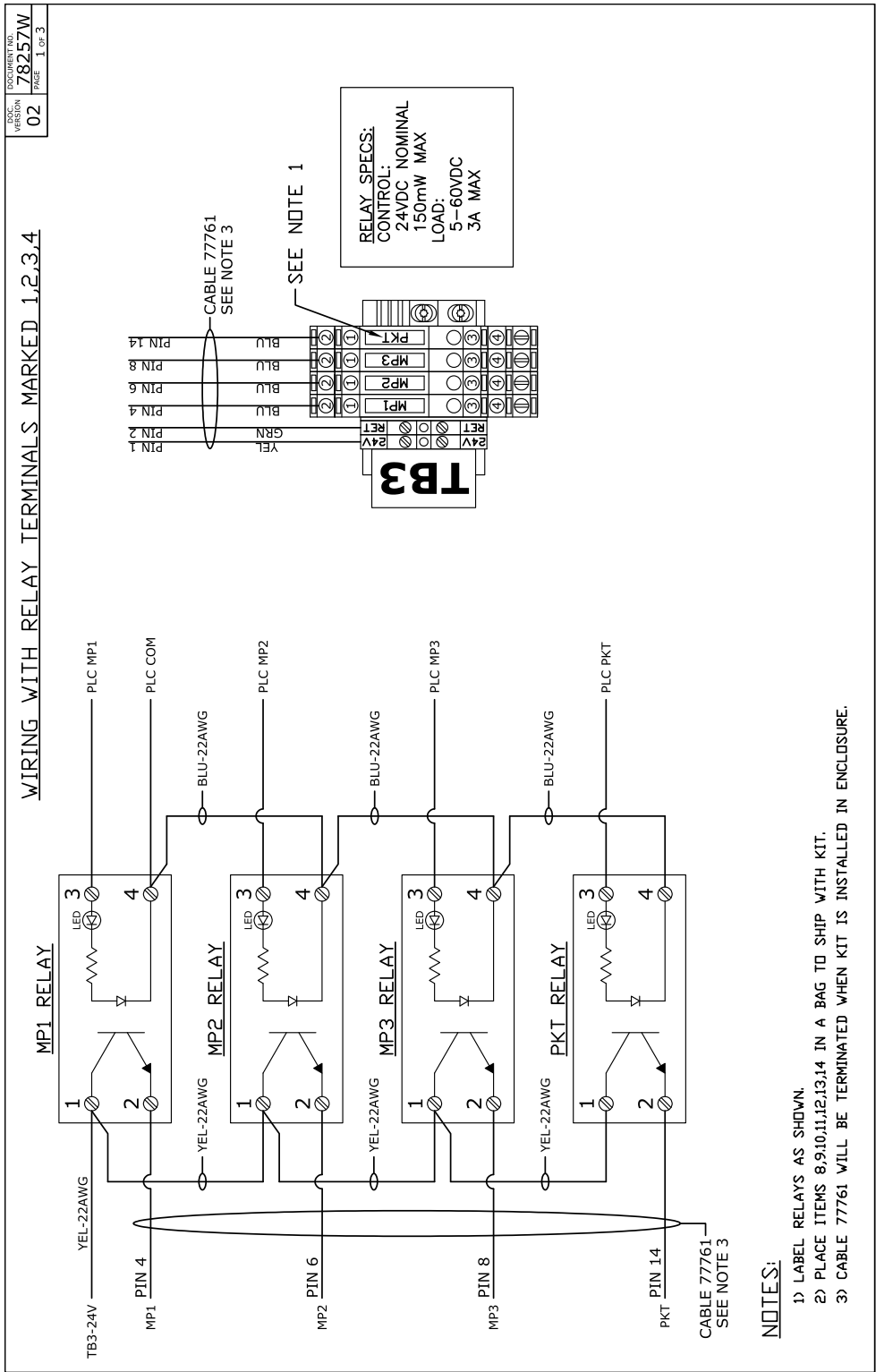

Wiring Diagram 78257 - 2 of 3 (relay terminals marked A1,A2,13,14)

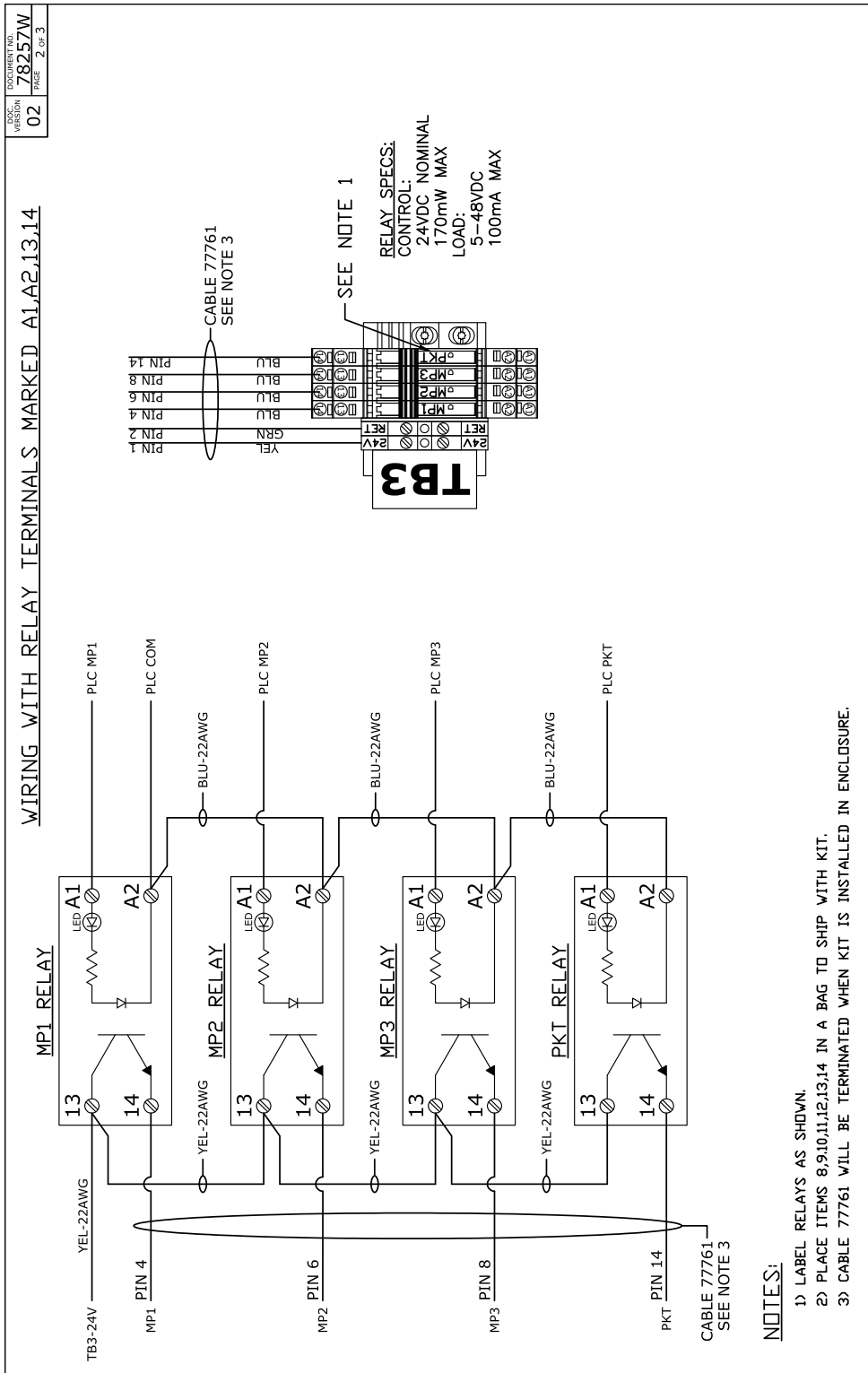

Wiring Diagram 78257 - 3 of 3 (TB3)

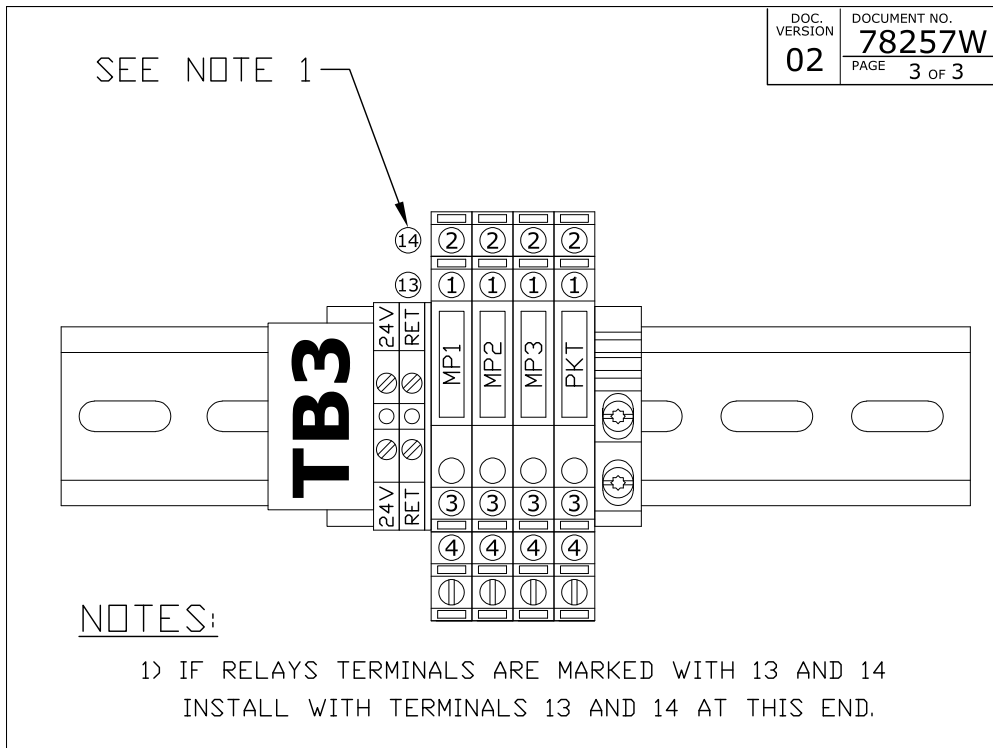

8 Port I-O Box

The I/O box is usually mounted near the tunnel. The cable from this box is plugged into the bottom of the control enclosure, connector A. Control Enclosure External Connections

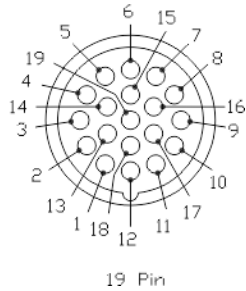
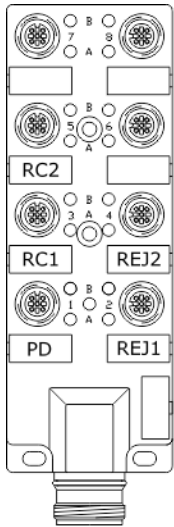

P/D - part detector

REJ1, REJ2 - rejector 1 and 2*

RC1, RC2 - reject confirm 1 and 2* (optional)

**DecoSpector 360™ does not use rejector 2 nor reject confirm 2*

4 Port I-O Box

The I/O box is usually mounted near the correlation sensors. The cable from this box is plugged into the bottom of the control enclosure, connector B.

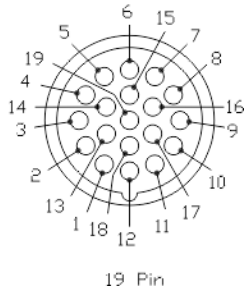
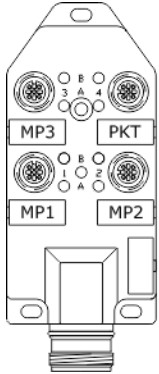

PKT - pocket detector

MP1 - MP3 - machine parts. These are configured through Correlation Settings

MP1 = Mandrel

MP2 - Print Blanket

MP3 = Pin Chain

Chapter 8 Inspection Module

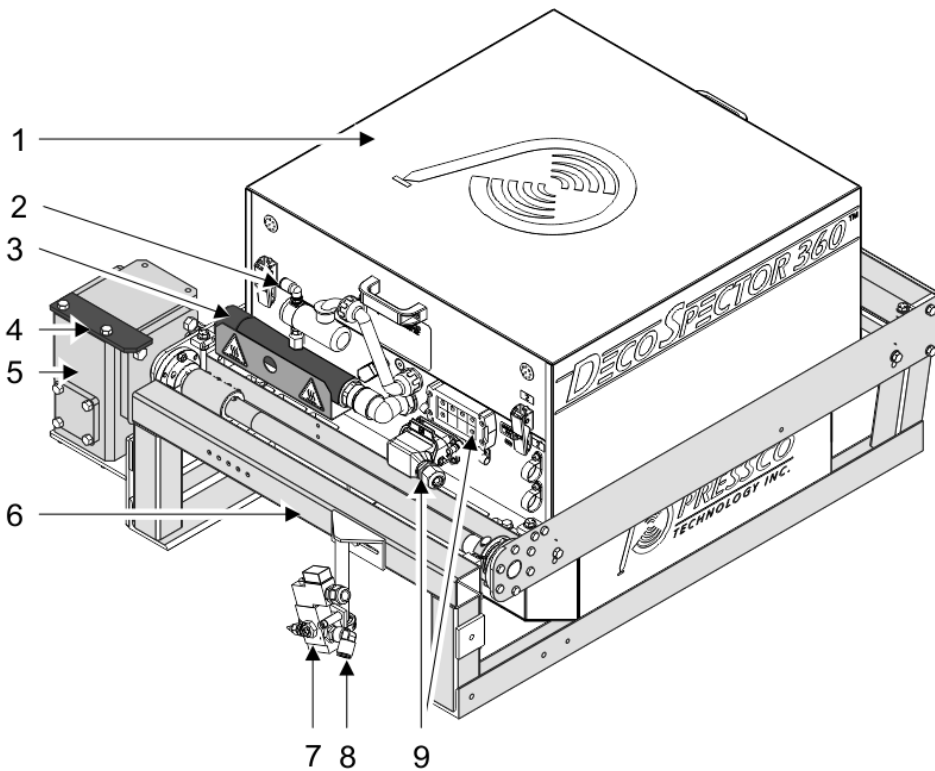

WARNING - Keep hands away from the Vortex cooler [3] to avoid risk of burns.

- 1) DecoSPECTOR 360™ inspection module
- 2) air connection for Vortex cooler
- 3) Vortex cooler
- 4) mechanical stop for the service frame
- 5) gear box for moving the service frame
- 6) service frame
- 7) air connection for the Vortex cooler
- 8) air connection for the rejector
- 9) connection for cables to the control enclosure

Chapter 8

This page left blank intentionally

Chapter 9 Troubleshooting

This section contains some possible errors that might occur with the DecoSpector system, and actions you can take.

Symptom	Possible Cause	Action
Cannot log in Pop-up window says "Deco has stopped responding" No camera images, or cameras not being found by system	Software error or crash	Restart the system: "Power On and Off at the Control Enclosure" on page 34 If the software is not responding, or restarting the system does not work, then: "Full Power Cycle for DecoSpector" on the next page
Reject rate too high, or false rejects	Learned parts or template have changed	Learn another set of parts: Relearn (or Learn Job)
	"Oil or Dirt on the Inspection Tunnel Windows" below	"Clean the Tunnel Windows" on page 98
Parts not being detected properly	The incorrect can size or can style is selected	Select the proper Can Size and Can Style for your part in the job setup New Part (First Time Inspecting a Part)
	Part location is not set properly. This often occurs when the part is not properly centered in the field of view, or there is more than one part appearing in it.	Check Part Locate Settings Check Lighting Settings

Oil or Dirt on the Inspection Tunnel Windows

You may be able to see oil or dirt on the inspection tunnel windows through the software. Look at the live images on the home screen. When you look at the image, the spot may show up in a different place horizontally for each part, but remains in the same place vertically between parts, as shown below.

"Clean the Tunnel Windows" on page 98



Full Power Cycle for DecoSpector

This procedure should only be performed when a standard power cycle does not work (example: the software is not responding).

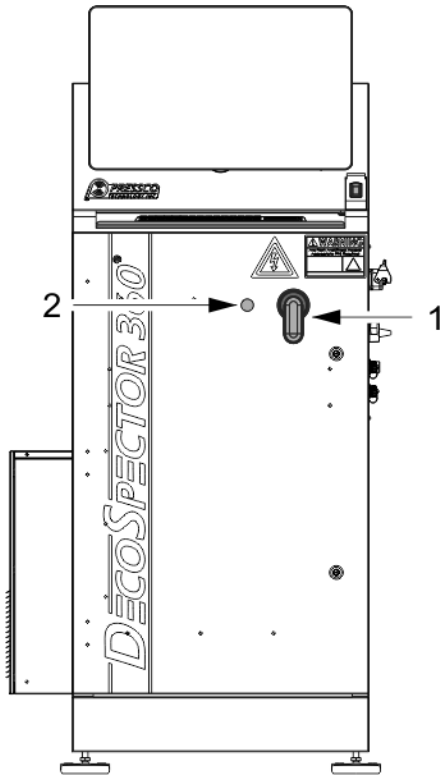

⚠ WARNING - Keep clear of reject devices. Projectiles may cause injury.

⚠ WARNING - When the system is powered down, there is still voltage present at the UPS. Only **AUTHORIZED PERSONNEL** should attempt to open the system. We recommend that only **AUTHORIZED PERSONNEL** have access to the keys.

1. If the software or Windows is locked up, then use [CTRL+ALT+DEL from the mechanical keyboard] and use Task Manager to stop "Deco.exe." Shut down the PC through Windows.
2. Turn off the main power switch [1].
3. Open the cabinet door, using the keys supplied by Pressco.
4. The UPS is on the back of the cabinet door. Shut off the UPS by pressing the on/off button for 3 seconds. Wait 1 minute before turning it back on, to allow components to discharge.



5. Turn on the UPS by pressing the on/off button for 3 seconds.
6. Close the cabinet door.
7. Turn on the main power switch on the cabinet. The software will start within a few minutes.

Chapter 10 Deco Extended IO

This optional module provides additional input and output ports for communicating with the DecoSpector 360™ system. The board is connected to the Part Tracker board via a ribbon cable inside the control enclosure.

In this section:

Extended I-O Signals	87
Defect Group I-O	89
Extended I-O Board	91
Extended I-O Circuits	91

Extended I-O Signals

The Extended I/O signals are listed in the table below. The Extended I/O board is located inside the control enclosure.

Note: For connection information, see ["PLC Correlation, Extended I-O Opto Relays 78746 \(Optional\)" on page 69](#)

Some signals are standard outputs from the system, such as "System State" through "Part at Reject" in the table below.

The Inspection Alarms are user-programmable. See External I-O for Alarms

Note: some input and output pins are not currently used

Output signals are selectable to be either open collector or open emitter. However, that selection applies to ALL output signals.

The input and power LEDs are visual indicators. The output LEDs illuminate if the current reaches 40mA or higher, which is approaching maximum current. The maximum current output is 50mA. See also information about ["Extended I-O Circuits" on page 91](#).

Signal	I/O	Connector	Indicator LED	Comments/ Reference
System State	O	J4-16	D11	Indicates whether the lane is online or offline. Online = active. Offline = inactive.
Part Present (Part Detect)	O	J4-18	D9	Pulses for 12 ms when the part present sensor detects a part
Part Good	O	J4-17	D7	Pulses for 12 ms for each part declared good by the inspection
Part Bad	O	J4-19	D5	Pulses for 12 ms for each

Signal	I/O	Connector	Indicator LED	Comments/ Reference
				part declared bad by the inspection
Part at Reject	O	J4-20	D13	Pulses for 12 ms for each part that crosses the reject point (online mode only)
Group 0 - Material Handling	O	J2-3	D17	<p>Pulses for 12 ms when an inspection fails</p> <p>Group Outputs are only valid with software versions 6.0.67 and higher</p> <p>See "Defect Group I-O" on the next page for a description of these signals.</p> <p>See "Extended I-O Board" on page 91 for the board layout and location of these outputs.</p>
Group 1 - Fixture	O	J2-4	D25	
Group 2 - Wrong Color	O	J2-5	D33	
Group 3 - Scuff	O	J2-6	D41	
Group 4 - Shadow	O	J2-7	D15	
Group 5 - Color Void	O	J2-8	D23	
Group 6 - Too Much Color	O	J2-9	D31	
Group 7 - Color Zone Defects	O	J2-10	D39	
Group 8 - Miscellaneous	O	J2-15	D21	
Group 9 - Camera 1	O	J2-16	D29	
Group 10 - Camera 2	O	J2-17	D37	
Group 11 - Camera 3	O	J2-18	D45	
Group 12 - Camera 4	O	J2-19	D19	
Group 13 - Adjacent Can	O	J2-20	D27	
Group 14 - not used	O	J2-21	D35	
Group 15 - not used	O	J2-22	D43	

Signal	I/O	Connector	Indicator LED	Comments/ Reference
Inspection Alarm 0	O	J3-3	D59	Goes active when the associated alarm condition occurs and stays active until the alarm is cleared
Inspection Alarm 1	O	J3-4	D67	
Inspection Alarm 2	O	J3-5	D75	
Inspection Alarm 3	O	J3-6	D83	
Inspection Alarm 4	O	J3-7	D57	
Inspection Alarm 5	O	J3-8	D65	
Inspection Alarm 6	O	J3-9	D73	
Inspection Alarm 7	O	J3-10	D81	
Inspection Alarm 8	O	J3-15	D63	
Inspection Alarm 9	O	J3-16	D71	
Inspection Alarm 10	O	J3-17	D79	
Inspection Alarm 11	O	J3-18	D87	
Inspection Alarm 12	O	J3-19	D61	
Inspection Alarm 13	O	J3-20	D69	
Inspection Alarm 14	O	J3-21	D77	

All Connectors	
Function	Pin
Isolated ground	1, 2
24 V (isolated)	13, 14

Test Points	
Function	Test Point
24 V	2
24 V Gnd	3
3.3 V	1
3.3 V Gnd	4

Defect Group I-O

This feature is valid on systems with software version 6.0.67 and higher.

Chapter 10

The DecoSpector 360™ system generates an output signal when specific defects are detected. The Group Outputs generate a signal for a total of 12ms when triggered. The signals are hard wired and not configurable. However, you can enable or disable the defect group outputs (all enabled or all disabled). To enable or disable the set, go to Settings | System Utilities | External I/O for Defects.

See "[Extended I-O Signals](#)" on page 87 (Group 0-15) for the pinouts of these signals.

The signals are:

- Material Handling - includes Empty Pockets and Out of Field of View parts
- Fixture - includes Registration, Out of Round, and Orientation defects
- Wrong Color
- Scuff
- Shadow
- Color Void
- Too Much Color
- Color Zones Defects
- Miscellaneous - includes:
 - Forced Reject
 - Missed Acquisition
 - Missed Inspection
 - Missed Result
- Camera 1 - a defect occurred on camera 1
- Camera 2 - a defect occurred on camera 2
- Camera 3 - a defect occurred on camera 3
- Camera 4 - a defect occurred on camera 4
- Adjacent Cans - only triggered when the system sees an adjacent can that has a defect

Extended I-O Board

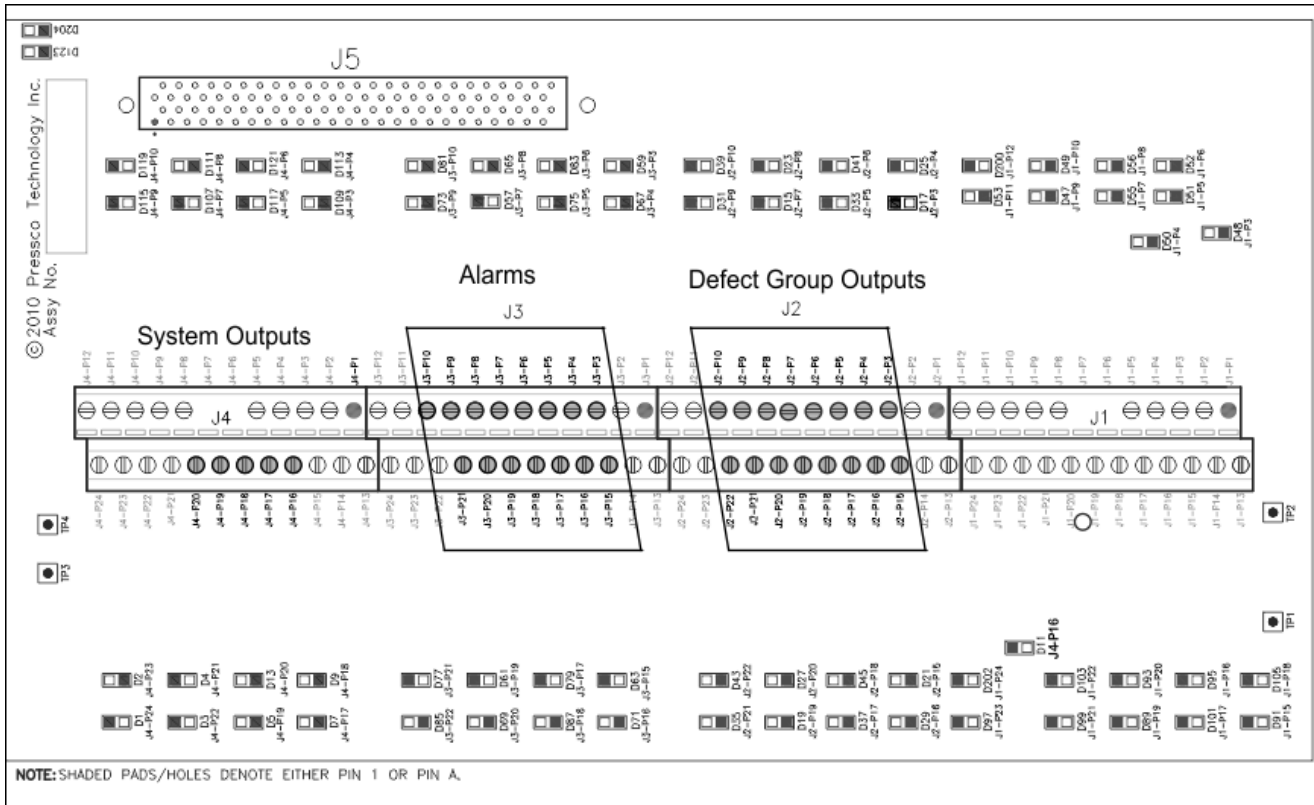

Extended I-O Circuits

The following illustrations show typical input and output circuits you can use to communicate with your plant's PLC, or to connect external LEDs or light trees.

Specifications:

- Minimum dwell time of the input device is 1.1 ms
- Maximum output load is 50 mA
- Default value of output pulse is 12ms. Some output signals, such as alarms, must be cleared on the Pressco system before they turn off.

Default timing of pulsed output



The following illustration shows a typical circuit that can be used for an alarm output.

ALARM 0 OUTPUT

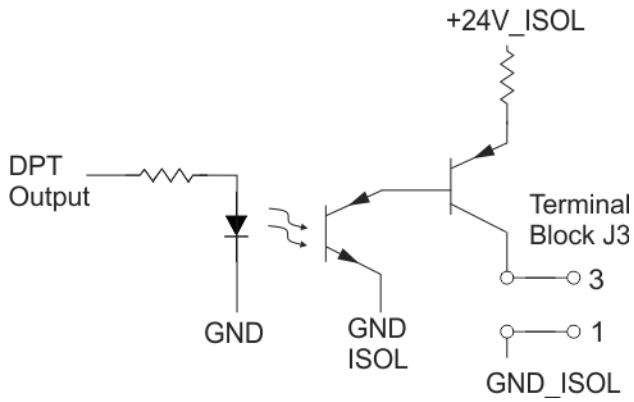

The following illustration shows a typical circuit that can be used to clear alarms.

Note: as of the time of this publication, extended I/O inputs are not available

CLEAR ALARMS - INPUT



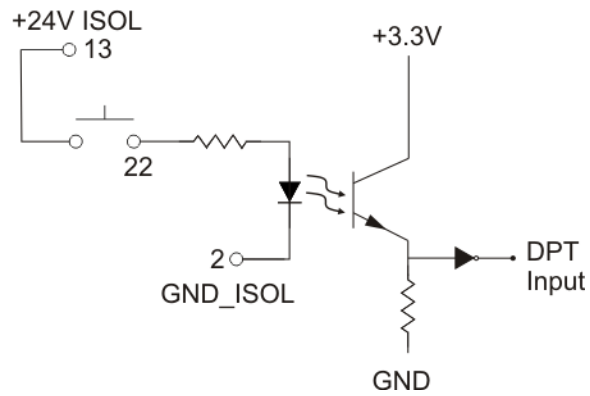



Terminal Block TB4



Chapter 11 Maintenance

Maintenance Cautions

When carrying out maintenance or repair work:

	Disconnect master switch. For switch locations, refer to the Power Up and Power Down section.
	Before starting the machine, ensure that no person is close to the machine.
	If maintenance or repair requires the disconnection or removal of safety or protection systems, this operation must be supervised by authorized personnel who must ensure the prevention of personal injury or damage to the machine. All machine movements must be performed with limited speed and limited movements.
	Maintenance or repair work on electrical components must be carried out exclusively by authorized, trained personnel. When running tests with power connected, you must strictly comply with the rules provided.
	Personnel working on higher parts of a machine must wear a harness and hook it on to the structure and must always move with extreme caution.
	Never perform lubrication or maintenance procedures on mechanical parts with the machine running.

LED Caution:

 **CAUTION** - Possible hazardous optical radiation from LEDs. Do not stare at lamps.

Preventive Maintenance Frequency

 **IMPORTANT** - The windows inside the inspection tunnel need to be cleaned regularly. The frequency depends on plant conditions, and could be as much as three or four times per shift.

Action	Frequency - Number of times per:					Supplies Required
	Shift	Day	Week	Month	Year	
"Clean the Tunnel Windows" on page 98	1x					Part number: 74284 - Kit Window Cleaning DS2 (includes plexi-glass cleaner and lint-free wipes)
"Clean the Control Cabinet Filters" on the next page				1x		Recommended: "RP Super Filter Coat Adhesive." Find this on the Internet or in a hardware store near you.

Action	Frequency - Number of times per:					Supplies Required
	Shift	Day	Week	Month	Year	
Replace the two Filter/ Regulator Filters: 30 minutes "Replace the Filter-Regulator Filters" on page 100						3x Part number: 67622 - Kit Oil Removal Replacement Filters

Clean the Control Cabinet Filters

The filter should be cleaned once a month for best results. The filter is located on the side of the cabinet. Replace with a new filter when necessary.

Note: You may need to clean the filters weekly depending on plant conditions

What you need:

Recommended: "RP Super Filter Coat Adhesive." Find this on the Internet or in a hardware store near you.

To clean the filter:

1. Pull the ring on the bottom of the filter cover, and pull the filter down to remove it. (see photo below)
2. Remove the filter and clean it. DO NOT use caustic solutions.
 - If the filter contains dry dust and dirt, flush the filter with warm water from the exhaust side to the intake side
 - If the filter contains oily dust and dirt, clean it in soapy water, then rinse in clear water
3. Dry the filter completely [placing it with a corner down will assure complete drainage].
4. Recoat the filter with "RP Super Filter Coat Adhesive." Spray both sides for best results.
5. Place the filter back inside the filter cover.

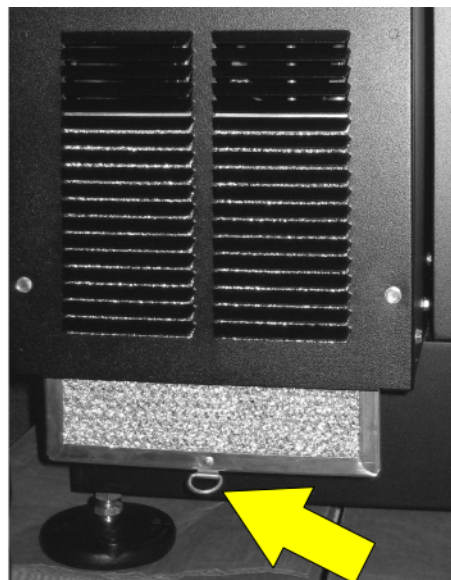
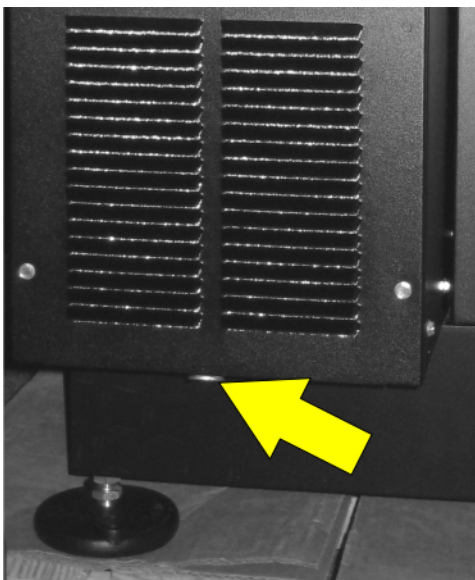

Service Frame

The service frame is used during inspection module maintenance and calibration.

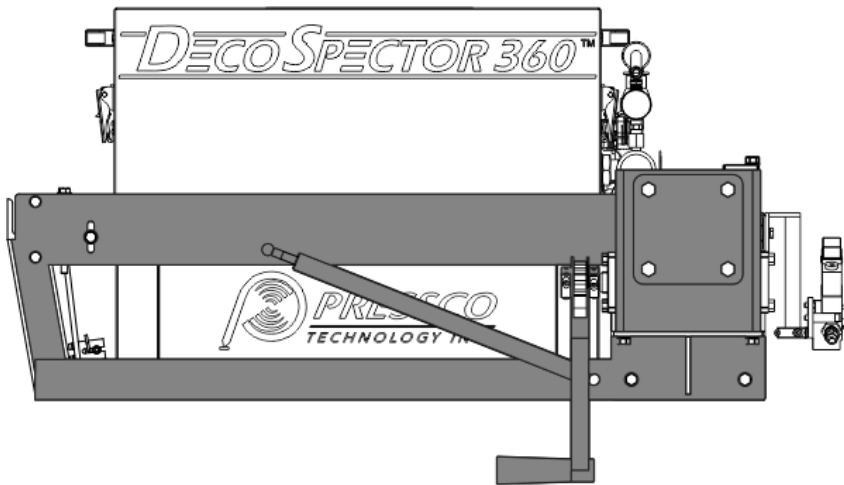

WARNING - This product contains no operator serviceable parts. Contact Pressco for service. How to Contact Pressco

- Do not open the gearbox enclosure. Oil may spill from the gearbox if it is opened.
- KEEP OFF the service frame. The service frame is not for lifting persons.
- KEEP OUT from under the raised service frame until it is secured by the locking device.

Use the Service Frame to Lift the Module for Maintenance

1. Use the handle [A] to lift the module. Turn handle [A] clockwise = module moves up. The handle contains a ratchet device, allowing movement in only one direction at a time.
2. Move the module up until it reaches the stop position [D].
3. Clean the module windows and perform other maintenance procedures as necessary.

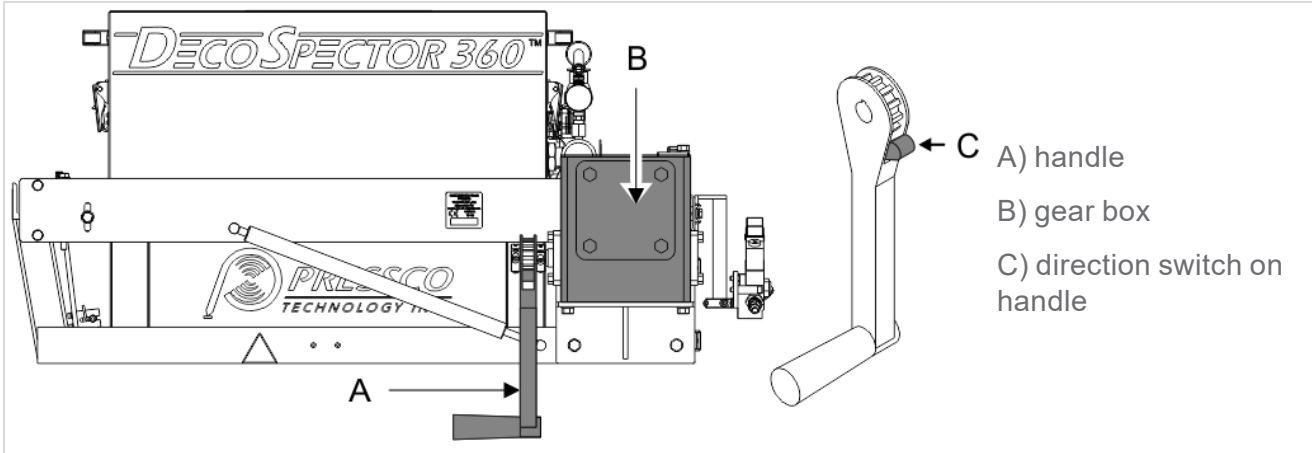

When you are finished with maintenance:

1. Push to release the locking mechanism [F].
2. Use the switch [C] on the handle to change directions.
3. Crank the handle [A] to lower the module. Turn handle [A] counter-clockwise = module moves down.

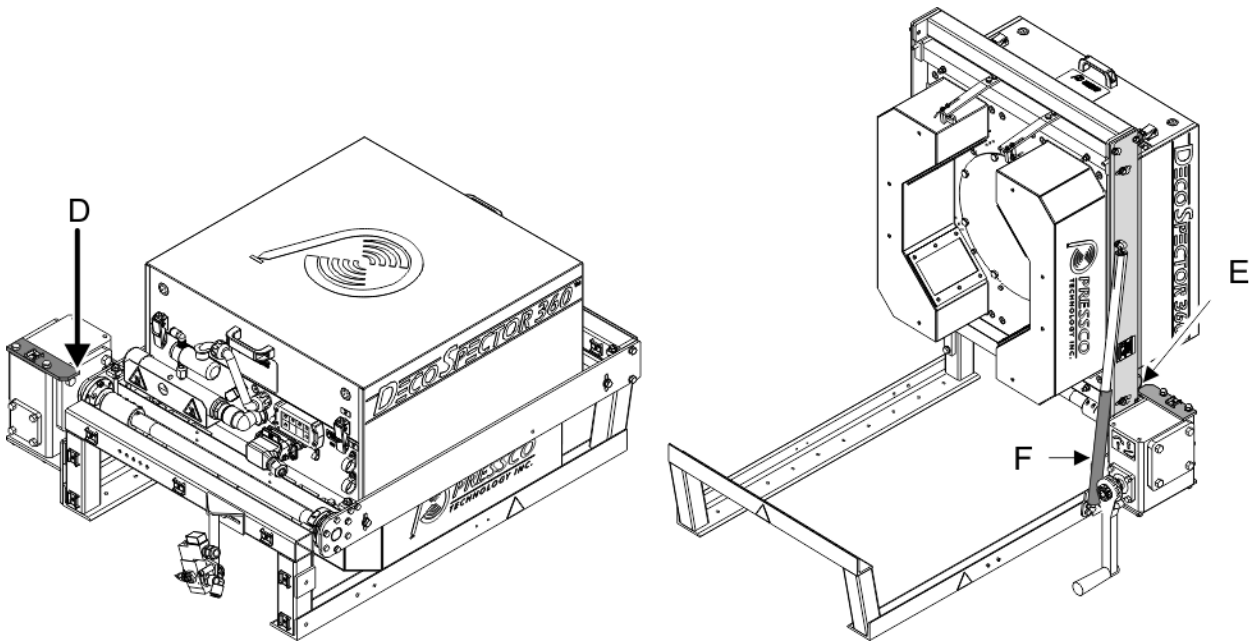

D) mechanical stop

E) service frame does not move after reaching the mechanical stop

Chapter 11

F) locking device holds the module in place while you work

Clean the Tunnel Windows

The inspection tunnel windows need to be cleaned at least once per shift, depending on plant conditions.



Important - Debris and contamination could build up on both the glass and plastic surfaces. This dirt could appear in the inspection windows, causing false rejects of parts, missed defects, or it could degrade lighting. Clean glass and plastic surfaces often.

What you need:

- Soft, clean, oil-free cloths
 - Recommended: Part number: 81945. It includes one bottle of lens cleaning solution and one box of lens cleaning wipes.
 - You may use supplies already in your plant, designed to clean safety glasses, such as Uvex Clear S463 liquid lens cleaner, with Honeywell Uvex Clear Lens Cleaning Tissues
- Mild soap and water solution
- Flashlight to see inside tunnel area
- Stopped production line - only for a short time when you swing the tunnel open and closed

Do NOT use:



Regular paper towels to clean the surfaces. These may scratch the surfaces or leave lint.



Alcohol-based solvents. These may damage the plastic surfaces.



Harsh chemicals. These may damage multiple surfaces.

To clean the windows:

1. Ensure the production line is stopped, and the area surrounding the tunnel is clear (of people, parts, equipment).
2. Turn the service frame handle clockwise to move the tunnel up and away from the production line.
3. Push the locking mechanism into place.

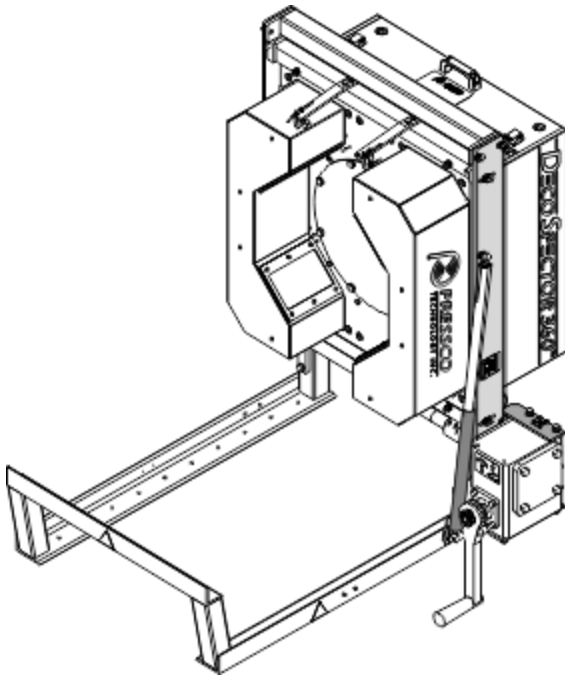

4. If desired, signal to someone in your plant to restart production, while you clean the windows.
5. Using a soft cloth and mild cleansing solution, clean all inspection and lighting windows inside the tunnel. Make sure all grease, oil, and other debris is removed.



6. If you have started production, signal to someone to stop it again.
7. Push to release the locking mechanism on the service frame.
8. Flip the switch to change directions of the service frame.
9. Crank the handle to lower the module back into place.
10. Start production.
11. Select the Relearn button in the DecoSpector 360™ software, so that the system learns parts with the newly cleaned windows.

Replace the Filter-Regulator Filters

The filter/ regulator assembly shown below is installed with the inspection module. Replace filters.

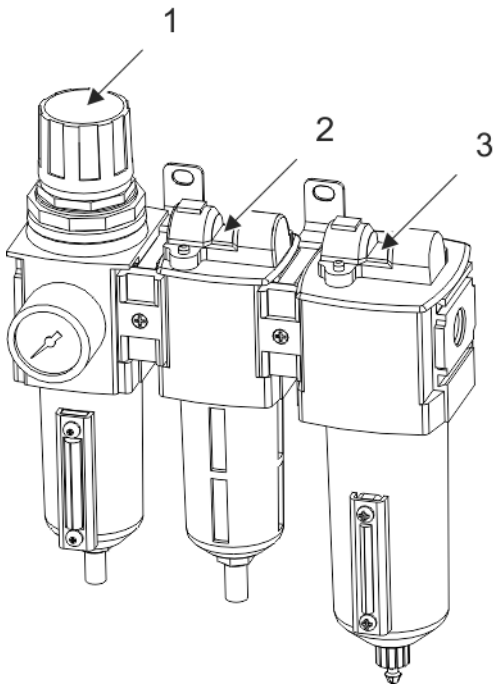

	Pressco part number	Description	Replace at least:
1		Filter/ regulator. No filter change necessary.	
	67622	Kit (contains one each of 67620 and 67621) It is easier to replace both of these filters at the same time	
2	67620	Filter oil removal	Every 2000 hours
3	67621	Filter oil vapor removal	Once per year