

INTELLISPEC™

Hardware Guide Series IV-D, IV-D+

Pressco Technology Inc.

Chromapulse™



Part number 65397 Rev. 03

© 2009 Pressco Technology Inc. All rights reserved.

No part of this manual may be reproduced or transmitted in any form or by any means, electronic or mechanical, including photocopying and recording, for any purpose, without the express written permission of Pressco Technology Inc.

The contents of this manual are furnished for informational use only, are subject to change without notice, and should not be construed as a commitment by Pressco Technology Inc.

Written and designed at:

Pressco Technology Inc. World Headquarters

29200 Aurora Road

Cleveland, OH USA 44139-1847

TEL 440-498-2600

FAX 440-498-2615

www.pressco.com

Table of Contents

Chapter 1 Introduction	5
What's New in Series IV-D Intellispec?	5
Typographical Conventions	6
Static Discharge Protection	7
Chapter 2 Intellispec System	9
Hardware Component Overview	9
How to Shut Down the Intellispec	16
How to Power Up the Intellispec	17
Chapter 3 Hardware and Software functions	19
Vision Processor Computer boards	19
Intellispec System Software	20
Intellispec System Block Diagram Series IV-D	22
Sequence of Inspection Events	23
Chapter 4 I/O Assignments	25
Input Signals and Devices	26
Output Signals and Devices	31
Light Tree	33
I/O signals - Test Point Reference	33
Ultra I/O Option	37
Chapter 5 Main I/O Board Series IV-D	43
Main I/O in Series IV-D	43
Main I/O Board, Front View	44
Main I/O Board, Rear View	45
Main I/O Jumper Settings	45
Main I/O Switch Settings	47
Main I/O Board LEDs and Test Points	49
Main I/O Daughter Board Pinouts	57
Main I/O Daughter board pinouts 2	58
Extended I/O daughter board pinouts	59
Chapter 6 Wiring Diagrams - Processor Cabinet S IV-D, D+	61
Cabinet Components S IV-D	61
Power Connections S IV-D	62
Main I/O Connections S IV-D	63
Gland Plate Connections S IV-D	64
Computer Connections S IV-D	65
FG Trigger Jumper S IV-D	66
Main I/O Front Connections S IV-D	67
AC/DC Power Drawer Wiring Details	68
AC Power Switch and Fan Wiring Series IV	70
Air conditioning unit multi-volt wiring S IV-D	71

Chapter 7 Jumper and Switch Settings.....	73
Circuit Board Protection	73
Chapter 8 Maintenance Frequency.....	87
Cleaning Optical Surfaces.....	88
Cleaning Glass Surfaces.....	88
Cleaning Plastic Surfaces	93
Cleaning the Ellipsoidal Mirror.....	94
Cleaning the Part Detector	95
Maintaining the Mounting Assembly	96
Replacing Filter/ Regulator Filters	97
Processor Cabinet Air Filter Maintenance.....	98
Chapter 9 Troubleshooting	101
Troubleshooting Flowcharts	101
Changing cameras in Series IV-D, IV-D+ systems	105
Additional Troubleshooting Hints	108
Chapter 10 Chromapulse™ Inspection Theory	111
Overview and Theory	111
Chapter 11 CP500, CP750 Modules	117
Description.....	117
System Level Interconnect CP750 Series IV	119
Adjusting the CP500 or CP750 Inspection Module	120
Maintenance of CP500, CP750, CP750E modules	124
Chapter 12 CP4402, CP4410 Belvac modules.....	127
Description.....	127
Belvac Interconnection Diagrams	129
Adjusting the CP4402 Inspection Module	136
Adjusting the CP4410 Module.....	140
Reject Settings	145
Chapter 13 CP4402E, CP4410E modules	147
Description.....	147
System Level Interconnect CP4402E/ CP4410E	151
Adjusting the CP4402E and CP4410E Inspection Modules	152
Maintenance	155
Chapter 14 CP4411E, CP4412E modules	157
Description.....	157
CP4411E/ CP4412E Interconnect Diagrams	160
Adjusting the CP4411E/ CP4412E Inspection Module	161
Maintenance	164
Chapter 15 CP/E Series Modules.....	167
Description of CP/E Modules	167
Interconnect Diagram CP/E Modules Series IV	170
Adjusting the CP/E series module.....	171
Maintenance	175

Chapter 16 Cable Wiring Diagrams 177
 Cabinet cables..... 178
 Chromapulse cables..... 185
 PET camera module cables 258
How to Contact Pressco..... 272
Index..... 273

Chapter 1

INTRODUCTION

This is your Hardware Reference Guide to the Pressco Intellispec Series IV-D and Series IV-D+ Vision Inspection Systems. This Hardware Reference Guide covers technical information necessary to adjust and maintain the Series IV-D and IV-D+ Intellispec Systems.

❖ *Note: Programming and user interface operations are covered in a separate manual titled “Intellispec Programming Guide”.*

WHAT'S NEW IN SERIES IV-D INTELLISPEC?

The information referred to in this manual as Series IV applies also to Series IV-D unless specified otherwise. 'D' indicates Digital system.

The differences between Intellispec Series IV and Intellispec Series IV-D systems include:

- Cameras are digital instead of analog. Camera names are designated with 'D' as in 'PD1'.
 - Series IV systems support analog cameras. Series IV-D supports digital cameras. No combination of analog/digital cameras in one system.
- Cables from cameras to distribution boards (in inspection modules) are new
- Coax cables replaced by Cat6 cables
- Frame grabber replaced by ethernet adapter and *camera switcher* (on page 16)
- Main I/O has new *shorting jumpers* (see "Main I/O Daughter board pinouts 2" on page 58) on camera personality board
- Network cable added from computer to *gland plate* (see "Gland Plate Connections S IV-D" on page 64)
- No multiplexed images. Each camera image is displayed individually.
- Software version 4.2.017 or later required for Series IV-D systems

What's new in Series IV-D+?

The differences between Series IV-D and Series IV-D+ include:

- Software version 4.4.004 or later required for Series IV-D+
- 20" LCD monitor on Series IV-D+. Series IV-D systems may have standard 15" monitors.
- Maximum eight digital cameras per system in Series IV-D+ (maximum four in Series IV-D)
 - Maximum four digital cameras per acquisition point (in one tunnel)

- Different *gland plate* (see "Gland Plate S IV-D+" on page 13) to accommodate additional video inputs
- **Camera switcher** (see "Camera Switcher S IV-D+" on page 16)
 - 16 port camera switcher (some systems)
 - dual five port camera switcher (some systems, after March 2009)
 - DHCP server software (after March 2009)
- New Chromapulse **camera signal distribution board** (see "Camera signal distribution board S IV-D+" on page 75) in inspection modules

Additional specifications

These specifications apply to all Series IV, IV-D, and IV-D+ systems

- Maximum four lanes per system
- Maximum four rejecters per system
- Maximum one BMID per Intellispec cabinet

TYPOGRAPHICAL CONVENTIONS

Following is a list of typographical conventions used in this manual:

- **Bold type** indicates a topic heading or an important item or statement.
- *Italicized type* indicates emphasis.
- Names of main components and system control signals have the first letter of each word capitalized. For example: Processor Cabinet.
- Danger messages appear as shown below:

DANGER

Danger messages alert you to specific conditions that can cause serious or fatal personal injury. Danger messages give you important information which must be observed to prevent injury. These messages are set off from the body text as shown here.

- Caution messages appear as shown below:

CAUTION

Caution messages indicate important information which must be observed to prevent: loss of data, poor system performance, or equipment damage. These messages are set off from the body text as shown here.

- Notes appear as shown below:
- ❖ *Note: Notes contain special information that warrants being set off from the body text as shown here.*

STATIC DISCHARGE PROTECTION



Caution

Electronic components can be damaged by static electricity discharge.

Always observe the following precautions before removing, installing or handling any electronic components within the Inspection System:

- Wear an anti-static wristband which is grounded to the Inspection System.
- Stand on an anti-static, grounded floor mat, and lay circuit boards on the mat during any board replacement.
- Keep circuit boards in static shield bags when storing and transporting. Ensure the bag is sealed.

Chapter 2

INTELLISPEC SYSTEM

HARDWARE COMPONENT OVERVIEW

The main hardware components include the Processor Cabinet, Inspection Modules for one to four production process channels, and the User Interface.

Processor Cabinet

The Processor Cabinet houses the System Computer, AC Transformer and DC Power Supplies, an Uninterruptible Power Supply, and the Main I/O Board. The Vision Processor Computer is an industrial PC with additional image acquisition and part tracking boards.

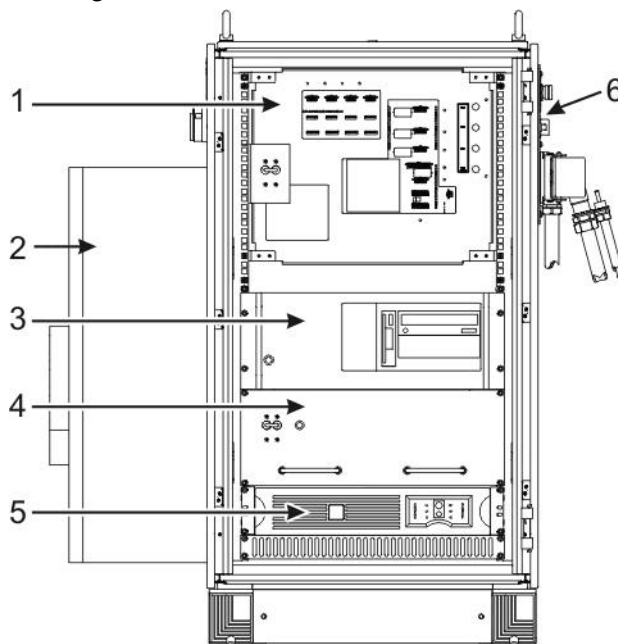

1	Main I/O board
2	Air conditioner
3	Vision processor computer
4	AC/DC power drawer
5	Uninterruptible Power Supply (UPS)
6	Gland plate

Inspection Modules

The Inspection Modules are usually installed on or near the users' production equipment. The Inspection Modules include the vision system cameras and part lighting devices. Part-present detectors, conveyor encoders, correlation sensors (optional), and part reject mechanisms are installed to track parts and reject defective product.

User Interface

The User Interface is mounted on a support caddy with adjustable arm. It includes a flat-screen monitor and a keyboard with trackball. It can be mounted either on top of the cabinet or on a *light tree* (on page 33) pole.

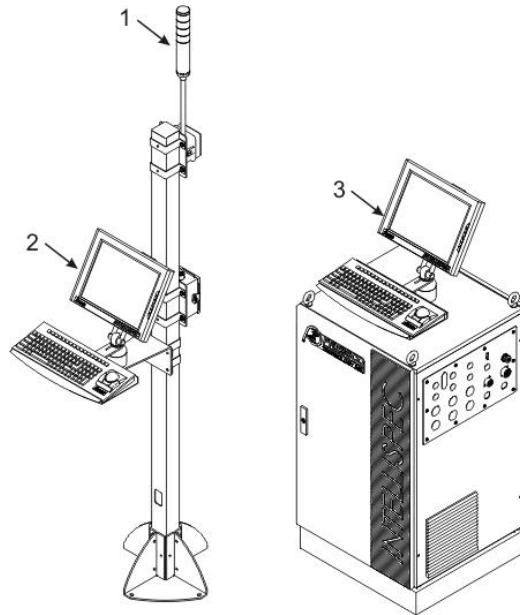

1	Optional light tree
2	Pole mount user interface
3	Cabinet mount user interface

Dual User Interface (optional)

Some systems may be equipped with two monitors and two keyboards/trackballs. The dual user interface is useful in plants that are inspecting multiple production lanes with one Intellispec, and the lanes are far apart. The user has quicker access to the lanes and statistics with the dual interface. These systems are also equipped with a switching device that allows automatic access to either interface.

Systems installed with Intellimass may have dual monitors, that display the Intellispec interface on one monitor and the Intellimass interface on the other monitor.

❖ *Note: Systems with a dual user interface support only one light tree – they do not support a light tree for each user interface.*

USING THE DUAL INTERFACE

Press any key or move the trackball to make a user interface the active one. It will become active automatically unless another keyboard or trackball is already active (e.g., someone is moving the trackball on the other user interface).

Both monitors display the exact same information. Any action performed on one user interface may be viewed on the other monitor.

MAKING THE CONNECTIONS

Warning

Power must be OFF before connecting any of the cables to the switching device. Turn off the switch on the side of the Intellispec cabinet.

The connections are made in our factory prior to shipment. Should any cable become disconnected, refer to the following diagram. Power up the Intellispec after all connections have been made.

Computer - rear view

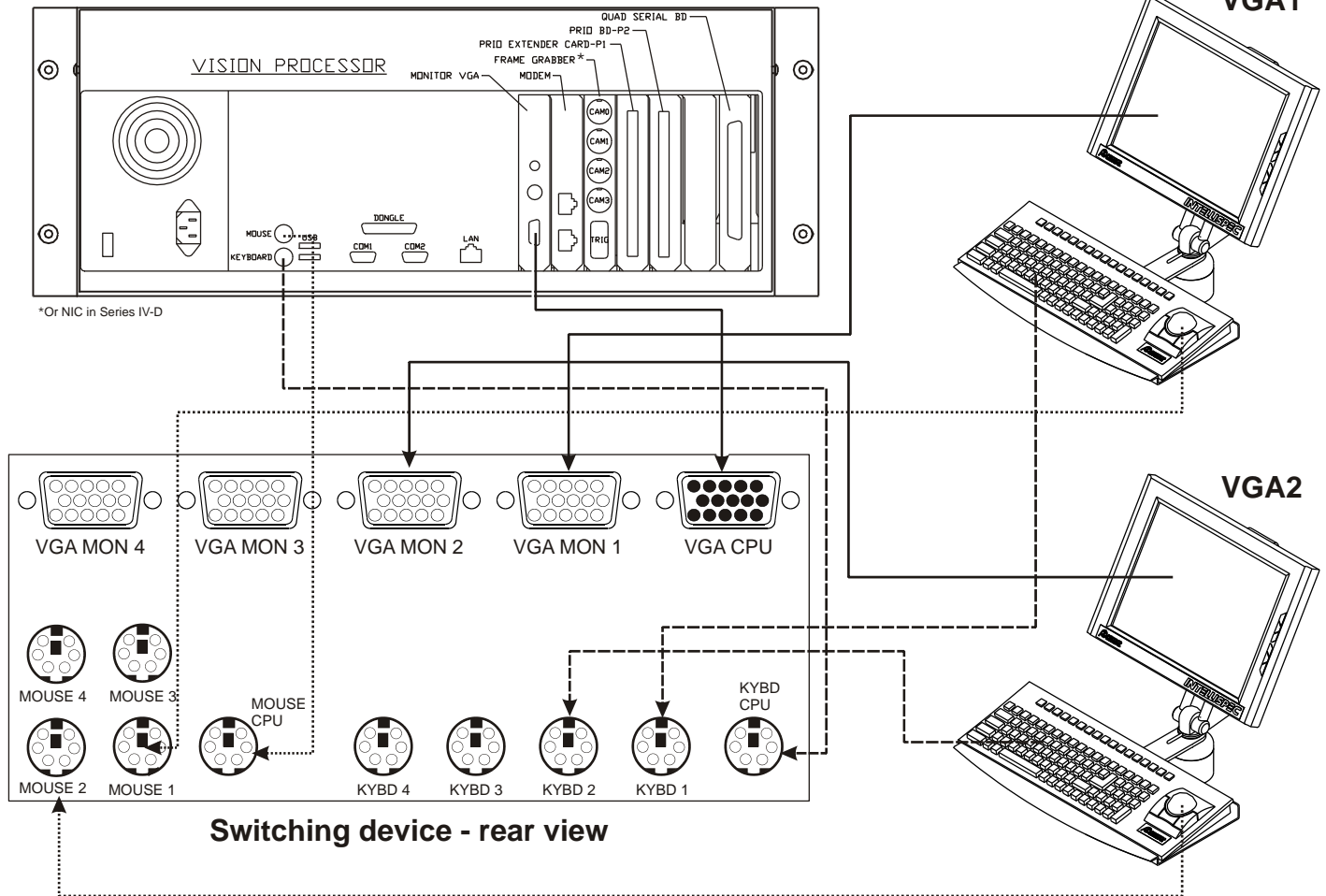

TROUBLESHOOTING

If any problems with the dual user interface occur, such as one interface operates correctly and the other one does not, use the following suggestions.

TROUBLESHOOTING SUGGESTIONS

Make sure power is OFF before connecting or disconnecting any cable or monitor.

- Make sure all cables are securely and properly connected.
 - If a cable is disconnected, turn OFF power switch on side of Intellispec cabinet
 - Make the cable connection
 - Power-up the Intellispec
- Make sure a monitor is connected to VGA MON1 on the switching device. Otherwise, the switching device will not operate properly.
- If you cannot solve the problem using the above suggestions, contact Pressco.

Processor Cabinet Components

The Series IV [or IV-D or IV-D+] **Processor Cabinet** (on page 9) is a floor-mounting, NEMA 12 type cabinet. It is the main enclosure for the Intellispec system electronics.

Connections on Side of Processor Cabinet

The illustration below shows the full names of the cables that connect on the side of the cabinet. This is called the Gland Plate. Your gland plate may vary, and may be abbreviated. This drawing is for reference only.

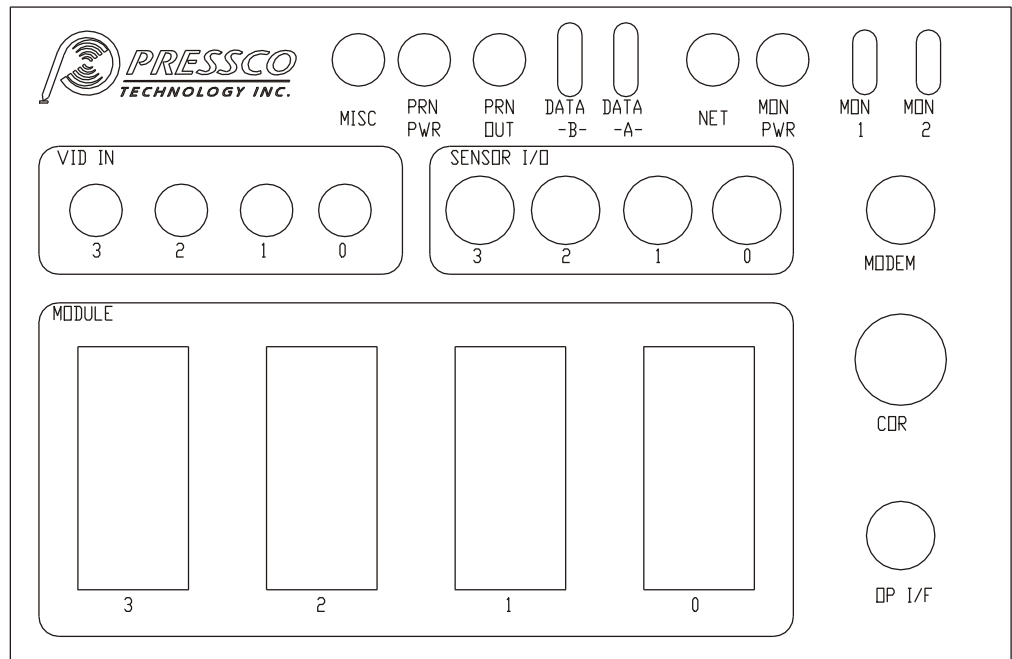

GLAND PLATE S IV-D+

In Series IV-D+ systems, there are extra video inputs, as shown below.

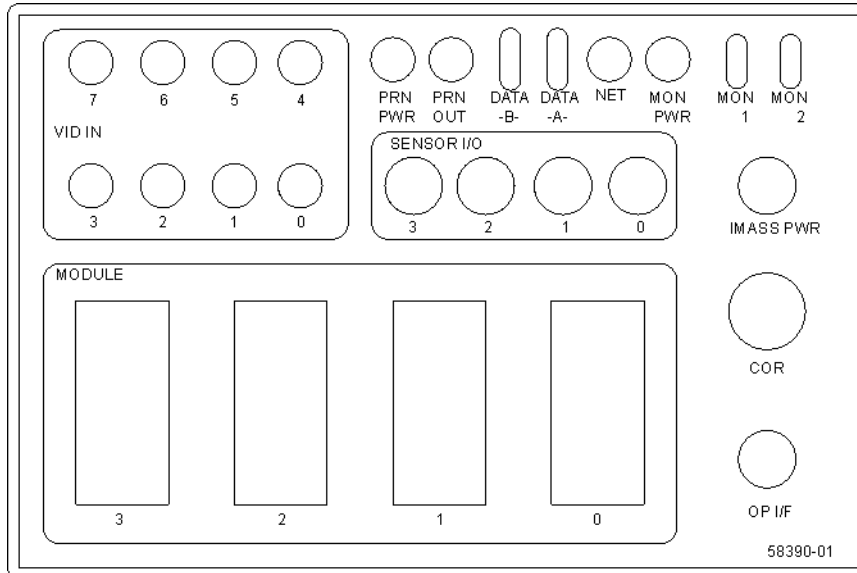

Vision Processor Computer

The Intellispec Series IV Vision Processor Computer (host PC) is an industrial PCI/ISA PC chassis mounted on support rails and fastened to the front end of the processor rack. The host PC includes a Windows® XP multi-tasking operating system. The host PC is specially configured for operating the Intellispec vision system.

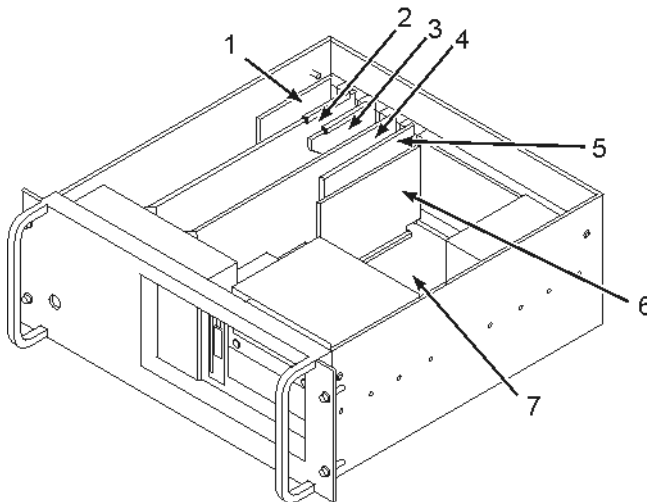

The boards in the **Vision Processor Computer** (see "Vision Processor Computer boards" on page 19) include:

1	4-port serial board
2	Pressco I/O (PRIO) board
3	PRIO extender board
4	▪ Frame Grabber (image acquisition) board in Series IV systems

	▪ Network Interface Card (NIC) in Series IV-D systems
5	Modem board (optional on some systems)
6	VGA board
7	Motherboard with integrated network board

❖ *Note: Whenever it is necessary to remove the computer, the cables on the rear of the computer must be disconnected first. Refer to **computer connections S IV-D** (on page 65).*

AC/DC Power Drawer

The AC/DC Power Drawer includes an AC section and a DC section. AC power to the cabinet is routed through a power ON/OFF switch and line filter to the AC section of the Power Drawer.

The AC portion of the Power Drawer includes a toroidal AC transformer and voltage distribution block. The AC portion provides 120 volts AC to the uninterruptible power supply and the processor cabinet cooling fans.

The LED on the front of the Power Drawer (if equipped) indicates that 120VAC is present at the Power Drawer from the UPS.

The DC portion of the power drawer includes five DC power supplies: PS1 (12V DC isolated), PS2 (24V DC isolated), PS3 (5/ 12V DC), PS4 (12V DC linear), and PS5 (48V DC).

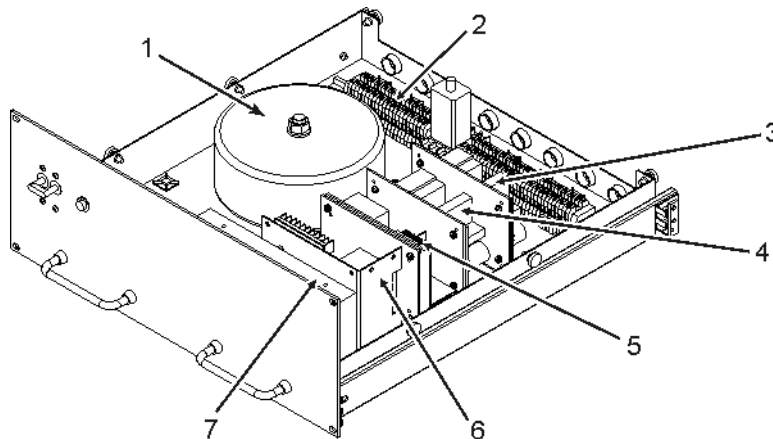

1	Toroidal AC Transformer
2	AC/ DC Voltage distribution block
3	PS1 - 12V isolated I/O power supply ▪ provides 12 volts isolated DC power to the power isolation circuits on the Isolated I/O boards
4	PS2 - 24V isolated I/O power supply ▪ provides 24 volts isolated DC power to the part sensors, system encoders, and part reject devices
5	PS3 - 5V/ 12V electronics power supply

	<ul style="list-style-type: none"> provides 5 volts DC to the Main I/O board and 12 volts DC to the camera module electronic circuits
6	PS4 - 12V linear camera power supply <ul style="list-style-type: none"> provides 12 volts DC linear to the inspection module cameras
7	PS5 - 48V array power supply <ul style="list-style-type: none"> provides 48 volts DC to light the inspection module lighting array LEDs

Also refer to *AC/DC power drawer wiring details* (on page 68).

Uninterruptible Power Supply (UPS)

The Uninterruptible Power Supply provides battery backup power for temporary Intellispec System operation in case of a power failure. AC power for system operation is routed from the AC section of the Power Drawer to the UPS and back to the DC section of the Power Drawer. Power conditioning electronics in the UPS ensure the AC output to the DC power supplies is free from voltage spikes and momentary power outages. A programmed power-down sequence ensures that the Intellispec System shuts down properly whenever the Main AC Power Switch is turned OFF.

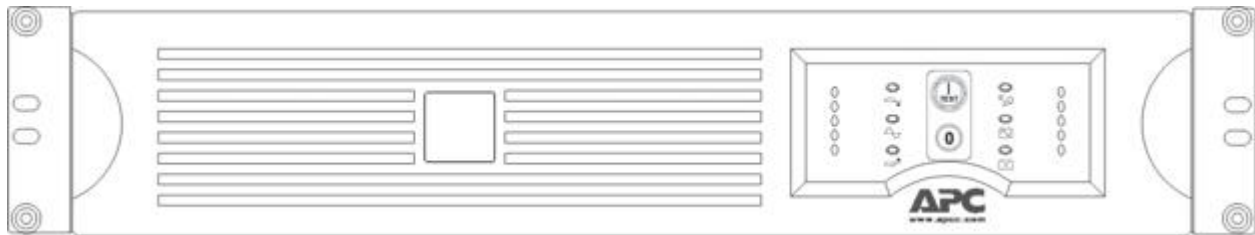

Main I/O Board

The Main I/O Board is mounted vertically to a support plate in the rear of the Processor Cabinet. The back side of the Main I/O Board provides input and output (I/O) communication with the System Computer and the UPS. The front of the board provides for communication with the visible/ audible alarm, the part position sensors, the encoder, the correlation sensors, and cameras. The sensor inputs and alarms are optically isolated; the vision system cameras are not.

The Main I/O board includes three daughter boards on the rear side: the Camera Personality Daughter Board and two Isolated I/O Daughter Boards.

The Camera Personality Daughter Board plugs into connector terminals J16 and J17 on the rear of the Main I/O Board. This board conditions the camera driver signals going out to the camera modules and the communication signals between the PRIO Board and the Image Acquisition Board.

The Isolated I/O Daughter Boards plug into connector terminals J36/J37 and J38/J39 on the Main I/O Board. This board uses optical isolators to isolate incoming part sensor signals, encoder signals, and actuator signals from the system electronic circuits. The Extended I/O isolation daughter board plugs into J21/J22 on the front of the Main I/O board. The Extended I/O signals are accessible on terminal strip TB1 on the *rear of the Main I/O* (see "Main I/O Board, Rear View" on page 45).

Camera switcher

The camera switcher transfers video signals from the gland plate to the ethernet board in the vision processor computer. This box is mounted on a plate near the inside top of the Intellispec cabinet. See the *wiring diagrams* (see "Gland Plate Connections S IV-D" on page 64) for further details.

Intellispec systems Series IV-D have a 5-port camera switcher.

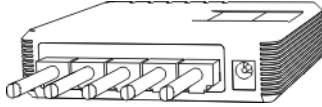

CAMERA SWITCHER S IV-D+

Some Series IV-D systems have a 16 port camera switcher.



Some Series IV-D+ systems have a dual 5-port camera switcher.

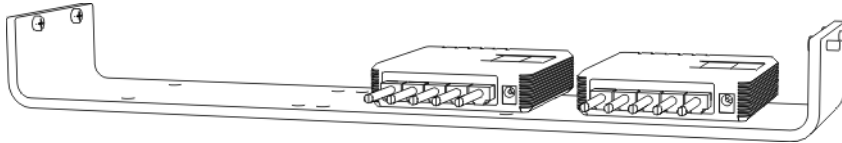

HOW TO SHUT DOWN THE INTELLISPEC

The Intellispec must be shut down properly, depending how the UPS is set up.

To see whether your system's UPS is configured:

USER LEVEL: ADMINISTRATOR

1. Log in. The system must be offline.
2. Click the  button.
3. Under the System tab, check the Show All Advanced Parameters button. The UPS is configured if the box next to 'UPS Configured' is checked.

If the UPS is configured

(All user levels) If the UPS is configured, simply switch off the rotary switch on the left side of the Processor Cabinet.

If the UPS is not configured

To shut down the Intellispec system, you must be logged in as an Administrator, and system must be Offline.

Warning

Do not shut off the power switch while the Intellispec is still running. The system must go through its proper shutdown sequence. This prevents loss of production data as well as possible program corruption.

To shut down Intellispec:

4. Click the  button.
5. Click Shutdown.

- Switch off the rotary switch on the left side of the Processor Cabinet.

HOW TO POWER UP THE INTELLISPEC

To power up the Intellispec, simply switch on the rotary switch (item 1) on the left side of the Processor Cabinet. After approximately 1 ½ minutes, the boot-up process will be complete.

The following three switches must be in the ON position:

- The breaker on the front of the AC/DC power drawer (item 3) (Up position for ON)
- The power switch on the right front of the UPS (item 4)
- The power switch on the left front of the computer (item 2)

Normally, these three switches can be left in their ON positions all the time.

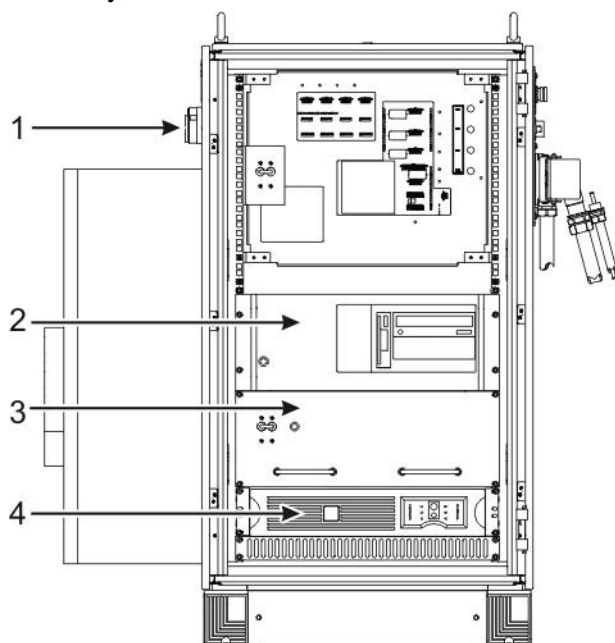

1	On/ off switch
2	Vision processor computer
3	AC/ DC power drawer
4	Uninterruptible Power Supply (UPS)

Chapter 3

HARDWARE AND SOFTWARE FUNCTIONS

VISION PROCESSOR COMPUTER BOARDS

The following topics briefly describe the function of the Intellispec system software and the operation of the circuit boards in the Vision Processor Computer. These boards include the PRIO board, the network interface board, the 4-Port Serial board, and the VGA board.

PRIO Board

The PRIO Board tracks each part from a Part Present detector to the part reject station. Part tracking is accomplished by counting encoder pulses. The encoder pulses enable the PRIO circuits to time the part progression through the inspection stations.

Based on adjustable position offsets, the Intellispec System knows exactly when each part reaches the inspection stations. Inspection camera and strobe signals are initiated according to the position offsets.

Part tracking is maintained until the part reaches the part reject station. Acceptable parts pass by the reject station. When a defective part reaches the reject station, the PRIO Board sends a Part Reject signal to the reject station. The part reject mechanism (compressed air or other user apparatus) removes the part from the part stream.

Also refer to the *sequence of inspection events* (on page 23).

Image Processing

The Part Present signal triggers the light module and camera. The light module illuminates the part and the camera lens projects the transmitted light onto a 640 x 480 grid of light sensors. Each light sensor generates a voltage related to the amount of light detected.

The digital scale used to represent the light detected by each sensor is called the gray scale. The gray scale values range from 0 to 255, with 0 representing the darkest pixel and 255 the brightest.

The video buffer assigns each digital value to an X-Y grid address. This allows the computer to access each pixel and read its gray level value. The grid size is 640 x 480 pixels. Pixel address X=1/Y=1 is located at the top left of the grid while X=640/Y=480 is located at the bottom right.

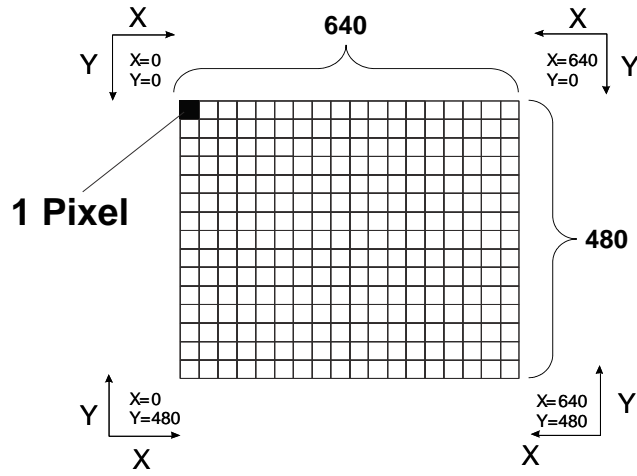

256 Shades of Gray

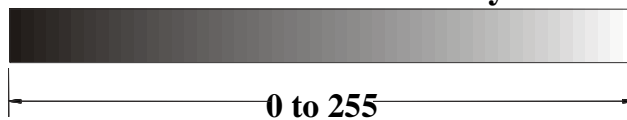

The Intellispec System inspects the gray scale data in one or more user-defined part inspection windows. The gray scale value of each pixel within the inspection window is compared to a specified threshold value (binary inspection), compared to another pixel within the window (edge detection), or entered into an algorithm for evaluation. Based on the results of the inspection, the Intellispec System accepts or rejects each part. If a part is defective, a message is sent to the PRIO Board. The PRIO Board issues a Part Reject signal for the related part. Accurate part tracking allows the Intellispec System to trigger the part reject device when the defective part reaches the reject station.

VGA Board

The VGA board copies camera images and textual graphics from the host PC memory and sends the images to the monitor.

4-Port Serial Board

The 4-Port Serial Board provides RS-485 communication networks for inspection station lighting control and camera focus control. The 4-Port Serial Board also provides RS-232 ports for communication with the uninterruptible power supply.

INTELLISPEC SYSTEM SOFTWARE

The Intellispec System software and host PC perform the following tasks:

1. **Acquire Image.** When in the Run mode (Online), the Intellispec acquires an image and provides a data storage location for the image data.
2. **Inspect the Image.**

3. **Send Pass/Fail Results.** After the image inspection is finished, the host sends a pass/fail result to the PRIO.
4. **Update Image Display.** A signal is then sent to the VGA to update the image display with the inspection image. (Several ways of displaying images are available.)
5. **Compile Statistics.** The Intellispec System software compiles and displays inspection statistics on user command.
6. **Communications.** The system software sends and receives information to and from the user interface.

INTELLISPEC SYSTEM BLOCK DIAGRAM SERIES IV-D

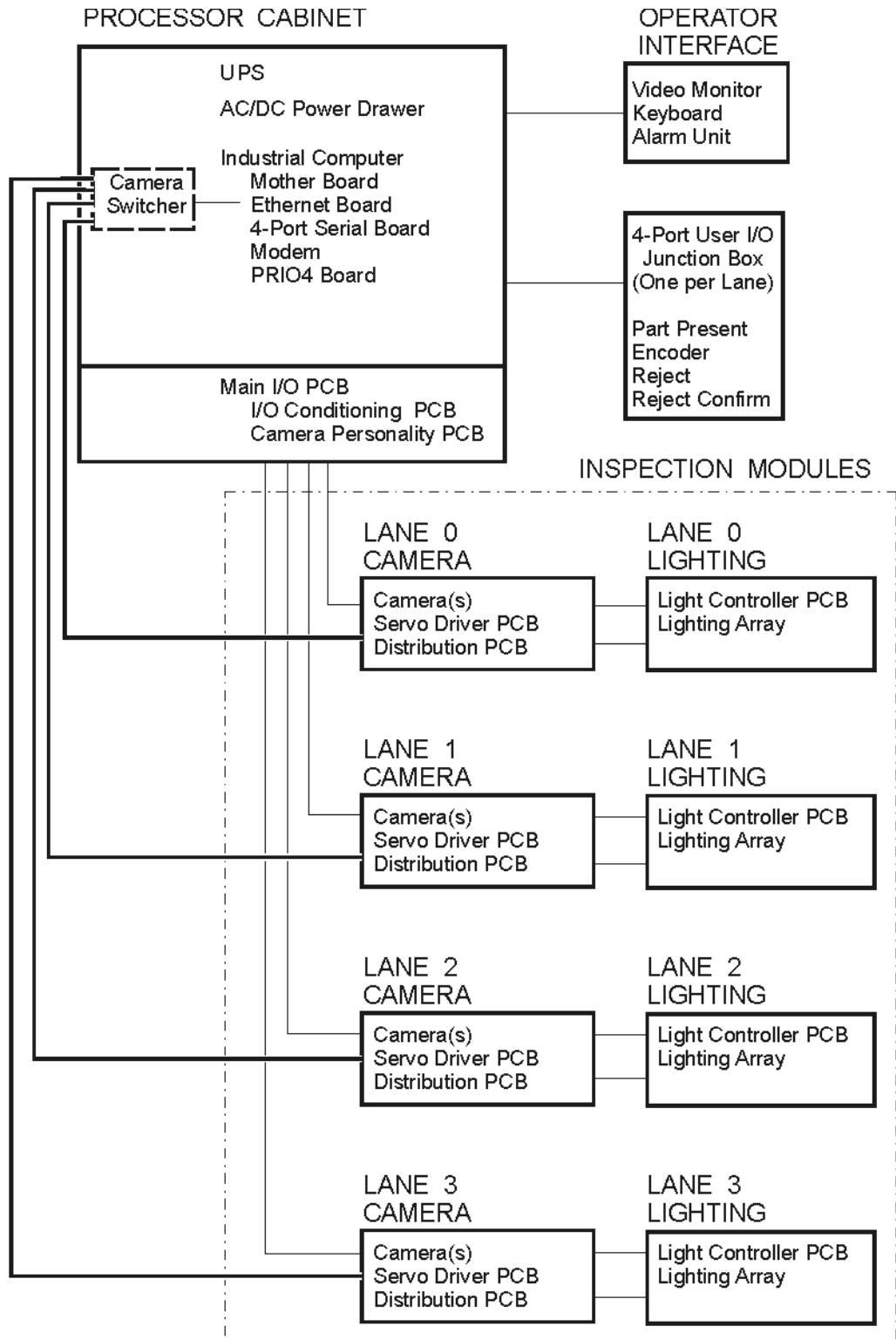

SEQUENCE OF INSPECTION EVENTS

The following sequence briefly describes how the Intellispec System inspects a part, processes the image data, and rejects the part if defective. The sequence of events is valid for all conveyor type parts.

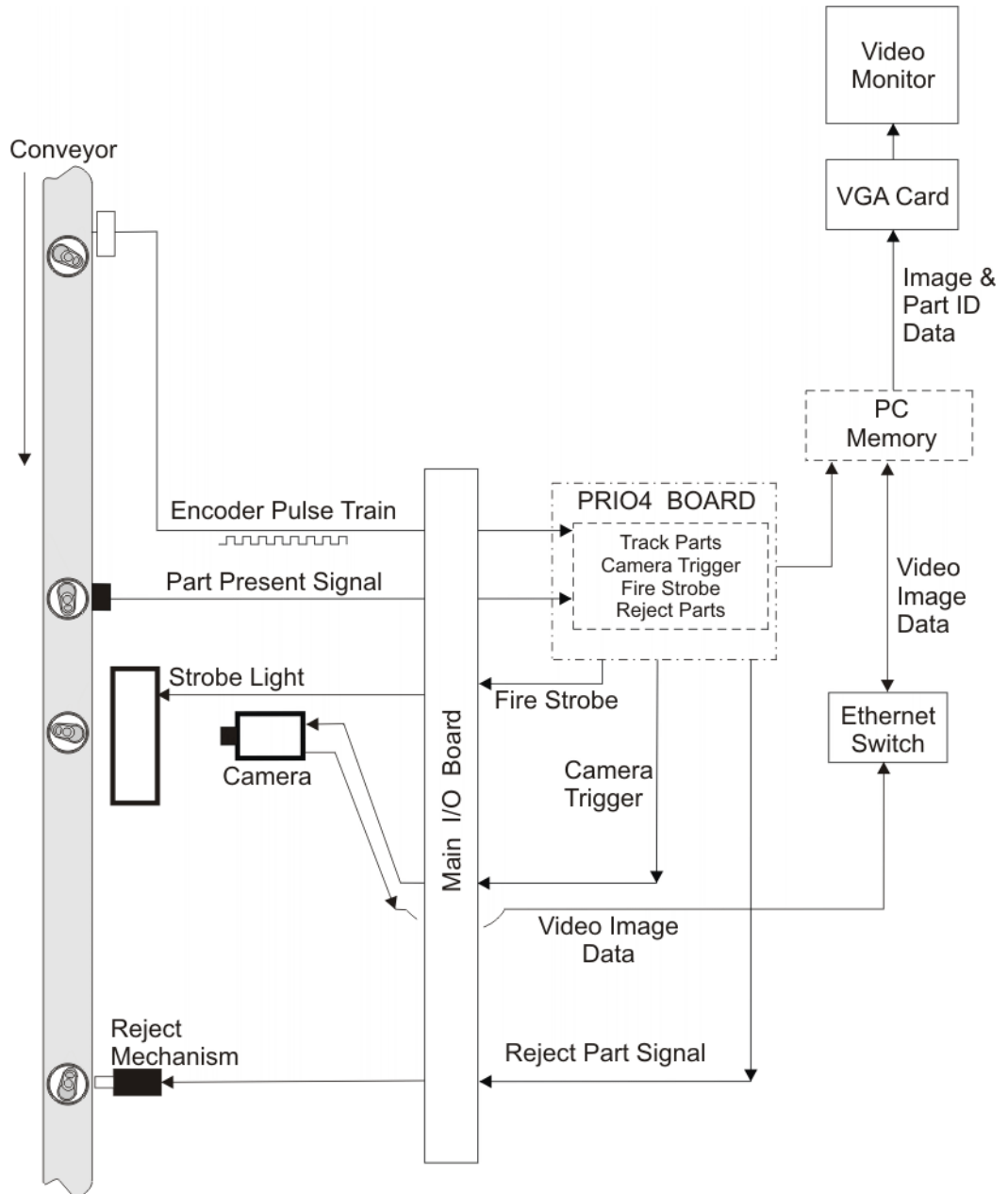

During the following inspection process, the Intellispec System is in Run Mode (Online). This description and above illustration mention only one camera, but all camera images are processed between part present sensor and reject station.

1. Part reaches the part present sensor.
2. PRIO informs the host PC that a new part is in the system and sends the host a part identity (ID) number (sequential count).
3. Part reaches the camera.

4. PRIO sends a trigger signal to the camera, sends a Fire Strobe signal to the inspection module, and informs the host that the part is at the camera.
5. PRIO sends a camera reset (shutter) signal, the host receives the digitized image, and signals the host that a new image is available.
6. The host inspects the image and sends the pass/fail inspection results to the PRIO results memory. The host signals the VGA to copy the image to the image display section.
7. The part reaches the reject station.
8. The PRIO examines the inspection results memory and sends a Part Reject signal if necessary.

The Intellispec System can simultaneously track up to 256 parts between the Part Present Detector and the Part Reject Station.

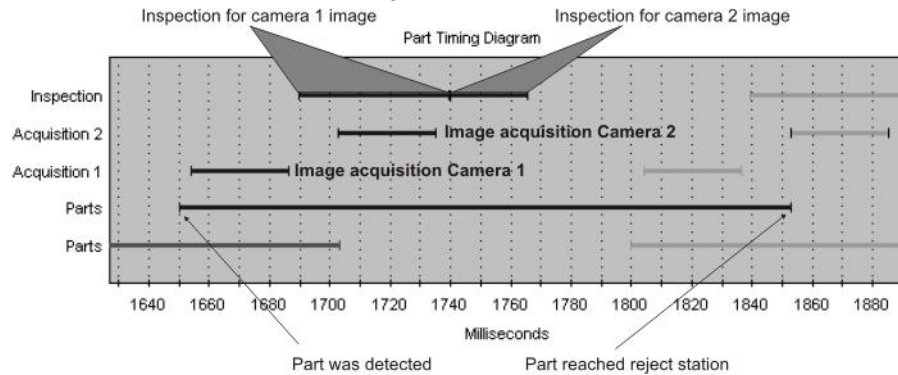

Chapter 4

I/O ASSIGNMENTS

The Intellispec System uses input and output signals to monitor and control part sensors, alarms, and other devices. The following section describes the Intellispec System input and output signals and their related control and monitor devices. The illustration below represents the I/O testing screen in Intellispec.

Inputs

0	Channel 1 Encoder	Channel 2 Encoder	Channel 3 Encoder	Channel 4 Encoder	Reject container full	Sidel door status	Ch. 1 part present	Ch. 2 part present
8	Ch. 3 part present	Ch. 4 part present	Transfer arm index	Spindle index	Cavity index	Pocket detect	Ch. 1 reject confirm	Ch. 2 reject confirm
16	Ch. 3 reject confirm	Ch. 4 reject confirm	Keyboard recover	AC power failure	Low battery backup	High temp.	Clear Alarms	Not assigned
24	Activate Inputs 25, 26, 27	Print Stats	Reset Stats	Print Indicator Values	Not assigned	Not assigned	Not assigned	Not assigned

32	Channel 1 reject	Channel 2 reject	Channel 3 reject	Channel 4 reject	Ch. 1 good part	Ch. 2 good part	Ch. 3 good part	Ch. 4 good part
40	Ch. 1 inspect. complete	Ch. 2 inspect. complete	Ch. 3 inspect. complete	Ch. 4 inspect. complete	Ch. 1 fire strobe	Ch. 2 fire strobe	Ch. 3 fire strobe	Ch. 4 fire strobe
48	Prog. Alarm output 1	Prog. Alarm output 2	Prog. Alarm output 3	Prog. Alarm output 4	Lighting reset	Online status	Visual alarm	Audible alarm
56	Warning indicator	Watch dog	Not assigned	Not assigned	Not assigned	System State (online/offline)	Part Present 1	Part Present 2
64	Part Present 3	Part Present 4	Group output one	Group output two	Group output three	Not available		
72								
80								

Outputs

There are many LEDs available on the Main I/O board to verify these signals. Refer to *Main I/O LEDs and test points* (see "Main I/O Board LEDs and Test Points" on page 48). Location of LEDs and test points on *Main I/O board, rear view*. (see "Main I/O Board, Rear View" on page 45)

INPUT SIGNALS AND DEVICES

Below are descriptions of the input signals available in Intellispec Series IV systems. The table, *I/O signals - test point reference* (on page 33), specifies where these signals are connected and where they can be measured.

Encoder

The Encoder is a pulse generator that is usually coupled to the production conveyor drive spindle. The pulse frequency input corresponds to the speed of the part conveyor. The number of pulses generated corresponds to the distance traveled by the part. A pulse counter on the PRIO Board allows the system to track the position of each part from the Part Detect Sensor to the Reject Station. Signal routed through 4 port I/O box.

Reject Container Full

Used mainly in systems installed within a blow molder – the Intellispec uses the blow molder’s internal reject chute. If the reject chute fills up while the system is in Run mode (Online), a Chute Full signal is sent to the computer, parts rejection stops, and an alarm signal is initiated. Part rejection is stopped until the Chute Full condition is corrected. Signal routed through 8 port I/O box.

Door Open

Used mainly in blow molder applications – the Intellispec’s inspection modules are installed inside. For safety reasons, if the door to the blow molder is opened while in the Run mode (Online), a door-open signal is sent to the computer. Parts rejection stops and an alarm signal is initiated. Signal routed through 8 port I/O box.

Part Present (Part Detect) Sensor

This sensor detects each part entering the system. It is usually a retro-reflective type sensor that signals the computer when a part breaks a reflected light beam. Signal is labeled PD and is routed through 4 port I/O box. Signal presence can be verified through the software:

- Diagnostics Tools button | I/O tab | Show I/O Rates to view Part Rate and Encoder frequency. The Encoder signal must be present to verify the Part Present Signal.
- Diagnostics Tools button | I/O tab | I/O testing to view the state of the Part Present signal. When viewing the I/O screen, look for the Part Present Signal to be changing state when parts are flowing. The I/O screen can only be accessed Offline. The Encoder signal must be present to verify the Part Present Signal.

Transfer Arm Index

Pulse from Transfer Arm sensor – used in systems with correlation. Alternate label is **Machine Part 2**. Signal routed through 8 port I/O box.

Spindle Index

Pulse from Spindle sensor – used in systems with correlation. Alternate label is **Pocket Detect 2**. Signal routed through 8 port I/O box.

Cavity Index

Pulse from Cavity sensor – used in systems with correlation. Alternate label is **Machine Part 1**. Signal routed through 8 port I/O box.

Pocket Detect

Pulse from Pocket Detect sensor – used in systems with correlation. Alternate label is **Pocket Detect 1**. Signal routed through 8 port I/O box.

Reject Confirm

Optional feature – additional hardware required. A part detect sensor positioned at a calibrated and defined distance past the normal reject mechanism determines whether a part was actually rejected. Signal routed through 4 port I/O box. See Intellispec Programming Guide for 3.1 software for details about this feature.

Keyboard Recover

Not used.

AC Power Failure

The processor monitors the Main AC Power Switch status. If the Main AC Power Switch is turned off while the system is otherwise powered up, an AC Fail input is sent to the computer and a warning is initiated.

Low Battery

Not used.

Over-temp Input

If the internal Processor Cabinet temperature exceeds a high limit, a temperature sensor sends an Over-temperature signal to the computer to initiate a fault warning. In the event of an over-temperature warning, the Intellispec System must be powered down to cool off and clear the warning.

Isolated User Inputs

The following are inputs that can be user-activated to gather statistical information. They are accessible on the *Extended I/O* (on page 30) terminal block TB1.

Clear Alarms

(IN1_ISOL) Clears all active alarms.

Activate Inputs

(IN3_ISOL) Alerts the software to read the status of the Print Statistics, Reset Statistics, and Print Indicator Values inputs and take appropriate action.

Print Statistics

(IN4_ISOL) Initiates a print of inspection statistics for all channels, plus correlation defects for all channels. (Correlation statistics printed only if Print File Type = Formatted text in Reports menu under System configuration). See Intellispec Programming Guide for information about file type, file naming, and file destination.

Reset Statistics

(IN5_ISOL) Resets the number of inspected parts and the number of defective parts to zero on all channels.

Print Indicator Values

(IN6_ISOL) Prints a report for each active indicator value for all currently running inspections.

Activate Input (IN3) must be energized to print statistics (IN4), reset statistics (IN5), or print the indicator value graphs (IN6). If you want to print statistics, for example, you must switch on IN4 (Print Statistics), and then toggle on and off input IN3 (Activate). Similarly, you must switch on IN5 (Reset Statistics) or IN6 (Print Indicator Value Graphs) and then toggle on and off IN3. Refer to the diagram below for timing details.

Signal

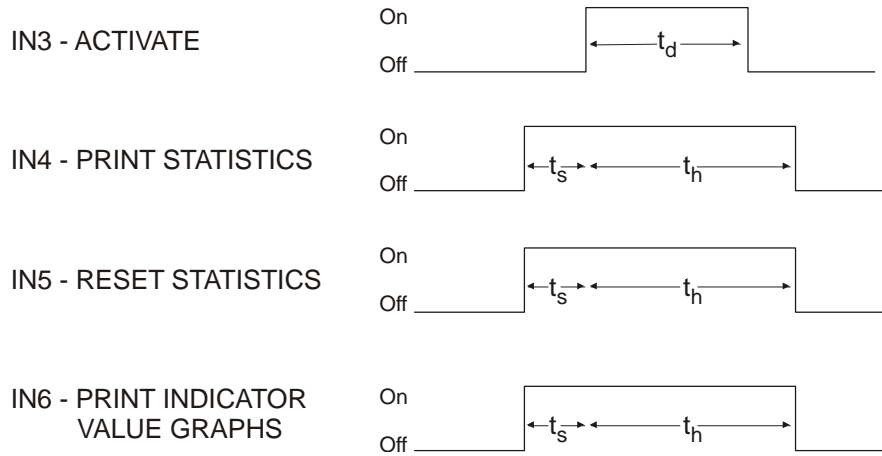

- t_d (minimum dwell time) – Equals twice the value of the maximum turn on time* of the input device
- t_s (minimum setup time) – Equals twice the value of the maximum turn on time* of the input device
- t_h (minimum hold time) – Equals twice the value of the maximum turn on time* of the input device plus 1 ms

Also, if you wish to use only one of the three inputs (e.g., IN4), you can leave that input on, and then simply toggle IN3 when you want to Print Statistics.

The following diagram shows a typical circuit that can be used to clear alarms. The same type of circuit can be used for any available input or output on the *Extended I/O* (on page 30) terminal block. A sample Correlation Reset circuit is also shown.

EXTENDED I/O INPUT/OUTPUT EXAMPLES

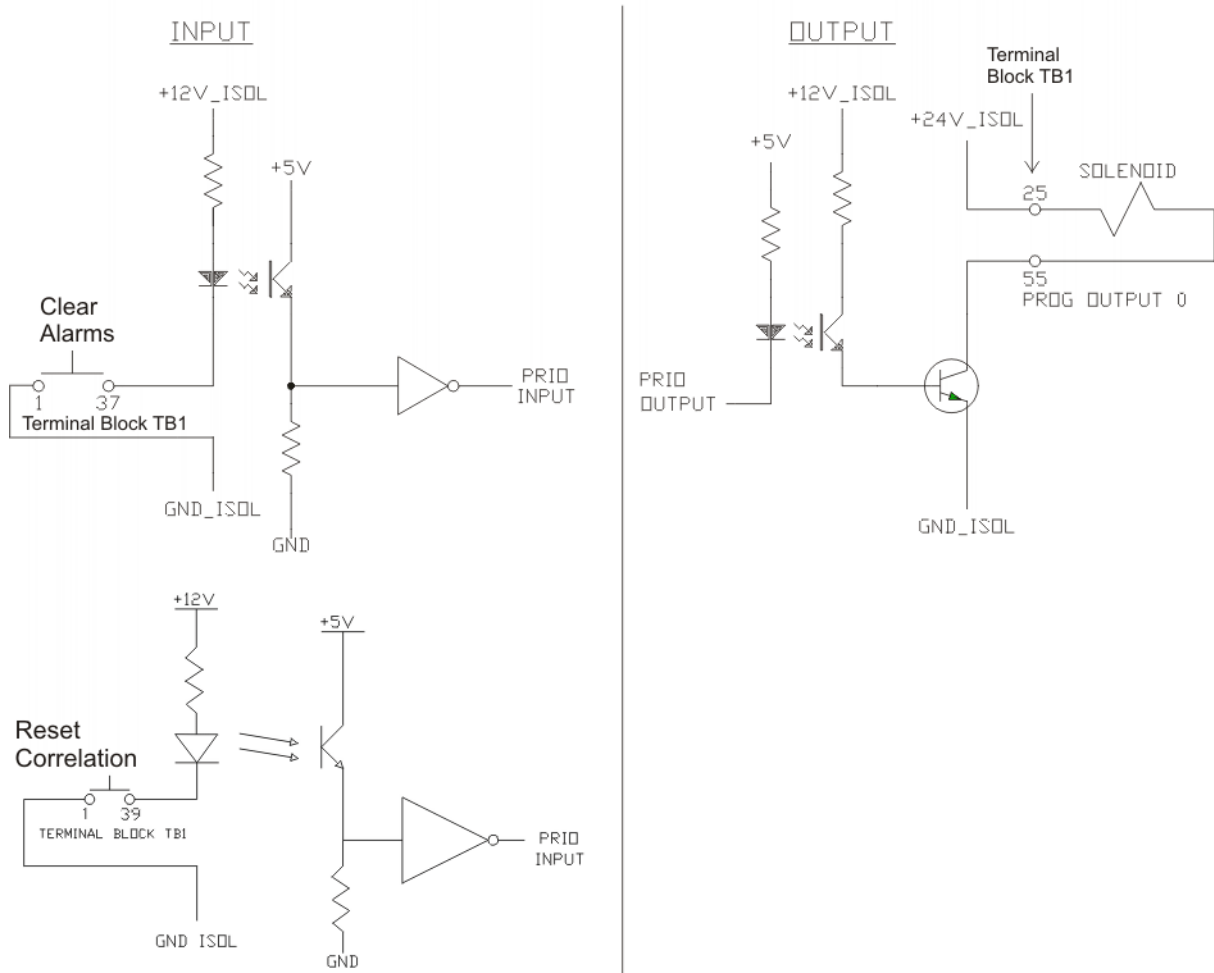

Extended I/O

Extended I/O terminal block TB1

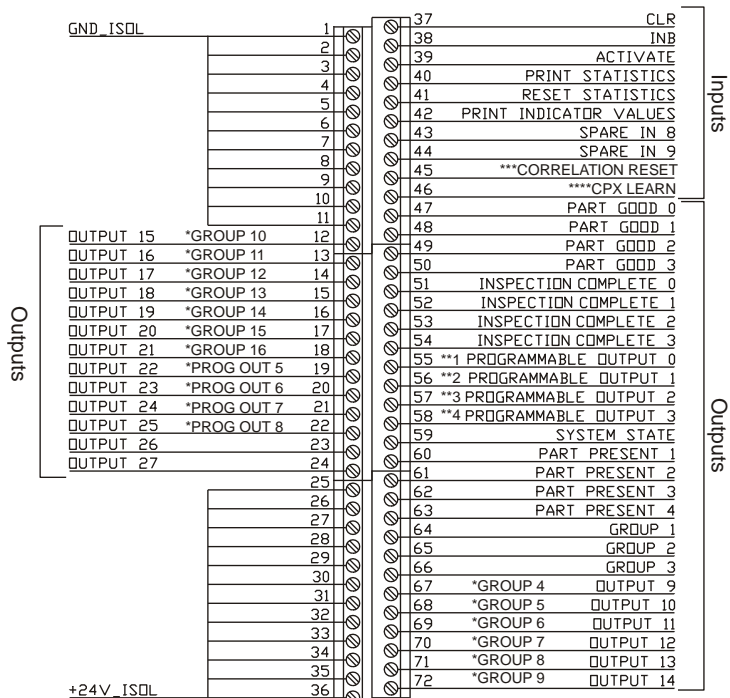

*Available with software version 4.0.027 and later

**Alarms Programmable Outputs labeled 1-8 in software

***Available with software version 4.5.xxx and later

****Available with software version 4.6.xxx and later

Correlation Reset and CPX Learn

Correlation Reset and CPX Learn allow you to connect a push button* to provide simple operator control. They are available as of the version of software listed below. When wiring these circuits, pay attention to the notes and sample wiring below.

*Only one push button should be connected, using either Correlation Reset or CPX Learn. Otherwise, both features become activated at the same time.

CORRELATION RESET

Available in software version 4.5 and higher.

To activate Correlation Reset:

1. Terminal 45 must be jumpered to any terminal 1-8.
2. Terminal 39 is what activates Correlation Reset. Therefore, terminal 39 should be wired to any terminal 1-8 through a momentary push button.

CPX LEARN

Available in software version 4.6 and higher.

To activate Extractor CPX Learn:

1. Terminal 46 must be jumpered to any terminal 1-8.
2. Terminal 39 is what activates CPX Learn. Therefore, terminal 39 should be wired to any terminal 1-8 through a momentary push button.

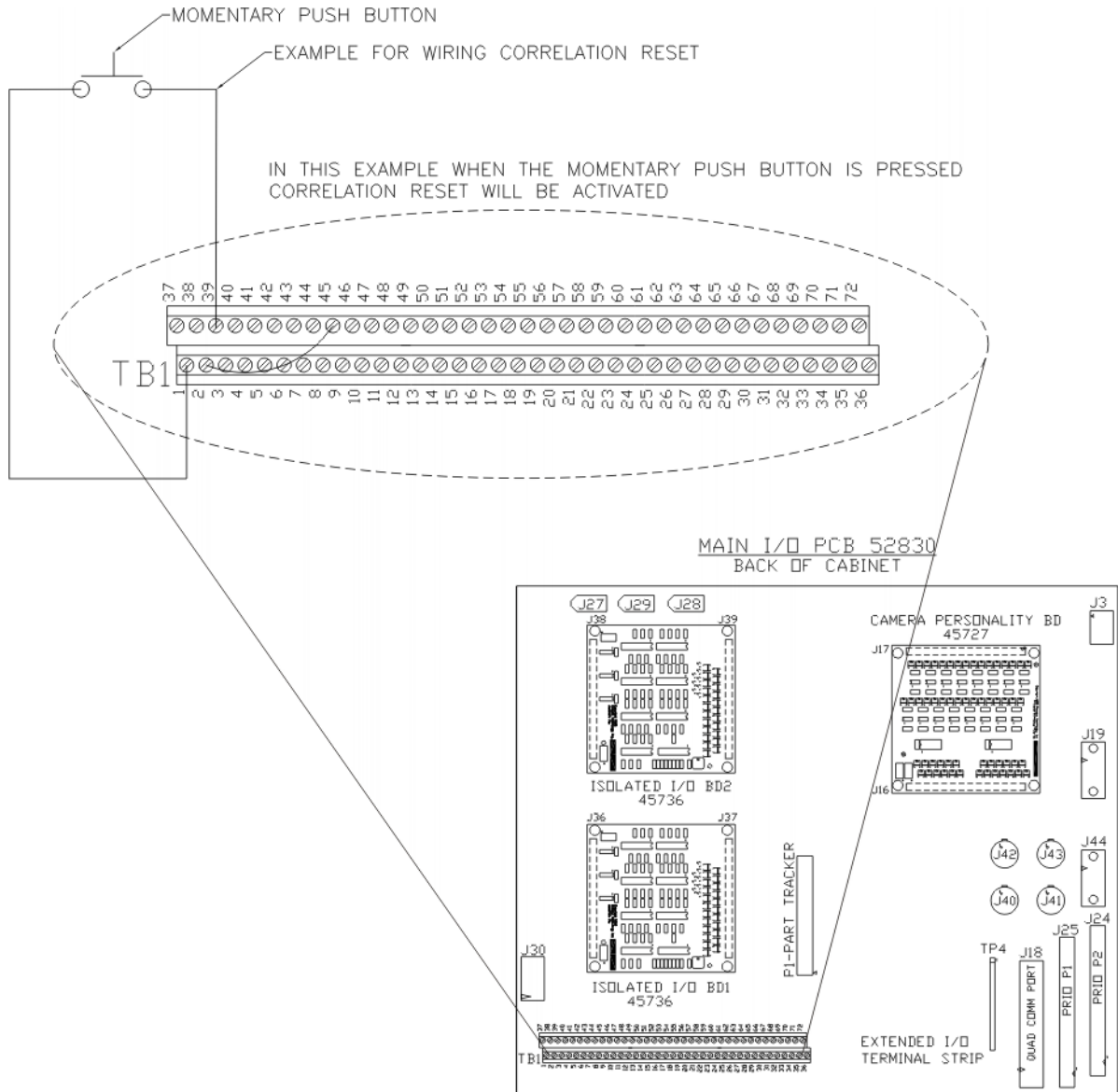

OUTPUT SIGNALS AND DEVICES

Below are descriptions of the output signals available in Intellispec Series IV systems. The table, *I/O signals - test point reference* (on page 33), specifies where these signals are connected and where they can be measured.

Part Reject 1-4

The Part Reject signal triggers the Part Reject mechanism. Signal is routed through the 4 port I/O box.

Part Good 1-4

Produces a pulse (of user definable length) for each good part that passes through the lane. See “Pass Pulse Width” on Tracking tab under System Configuration | Channel Groups menu.

Inspection Complete 1-4

Produces a pulse (of user definable length) for each part that passes through the lane. See “Complete Pulse Width” on Tracking tab under System Configuration | Channel Groups menu.

Fire Strobe 1-4

This signal is hard wired to the light controller. It produces a pulse to fire the strobe for each part that passes through the lane.

Programmable Alarm Output 1-8

User selectable outputs tied to the activation of alarms. Outputs go active when alarm initiates, and go inactive when alarm is cleared.

Lighting Reset

Resets all light control boards to their previous state (not to zero).

Online Status

This signal is hard wired to the light tree. It lights the green light when the system goes online.

Visual Alarm

This signal is hard wired to the light tree. It lights the red light when an alarm condition occurs.

Warning Indicator

This signal is hard wired to the light tree. It lights the yellow light when a warning status is present.

Watchdog

This signal is hard wired to the light tree. It flashes the red light and horn at a 1 Hz rate if the system goes into an un-recoverable state.

System State (Online/ Offline)

Indicates whether the system in Online or Offline. Online = Active. Offline = Inactive.

Part Present 1-4

Produces a pulse for each valid part present.

Group Output 1-3

Produces a pulse when any inspection within any group assigned to that output fails. See “Inspection Grouping” in Intellispec Programming Guide for more information.

LIGHT TREE

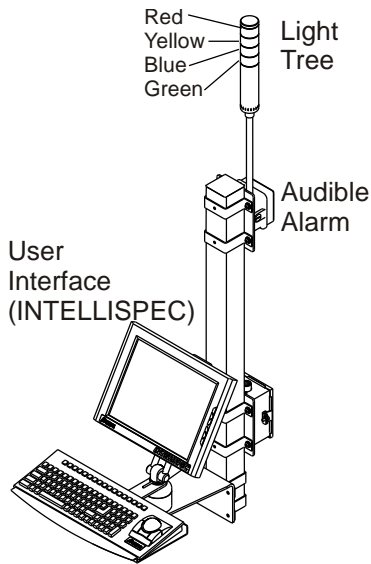

Alarm Light

When an alarm condition is active, the computer sends an Alarm Light output to illuminate the **red** Light Tree indicator lamp. Use the *Digital I/O* (see "I/O Assignments" on page 25) screen to verify lamp operation.

List of available alarms is found in the Intellispec Programming Guide.

Run mode (Online) Light

When the system is in Run mode (Online), the computer sends a Run mode (Online) Light output to illuminate the **green** Light Tree indicator lamp.

The light can be tested offline: use Diagnostics Tools button >> I/O >> I/O testing. Look at "Online Status" output.

AC Power Light

When the Rotary AC Power Switch is turned ON, an AC Power Light output illuminates the **blue** Light Tree indicator lamp.

Warning Light

When a warning condition is active, the computer sends a Warning Light output to illuminate the **yellow** Light Tree indicator lamp. Use the I/O testing screen to verify lamp operation.

Audible Alarm

When an alarm condition is active, the computer sends an Audible Alarm output to sound the alarm.

I/O SIGNALS - TEST POINT REFERENCE

The following table references the I/O assigned numbers (in the software), and the best place to measure these signals.

Notes:

- Signals are labeled 0-3 (e.g., Lane 0, Lane 1, Lane 2, Lane 3) in hardware, but are called 1-4 (e.g., Part Detect 1, 2, 3, and 4) in software
- When measuring on J36 or J38 reference TP5 on the Main I/O board
- J17 signals are differential outputs and should be measured with respect to each other or can be referenced to TP1 on the Main I/O board

I/O number on screen	Signal	Type	Connection Point	Test Point
0	Encoder 1 (ENCODER_0)	Input	Lane 1 Distribution Box	J36-3
1	Encoder 2 (ENCODER_1)	Input	Lane 2 Distribution Box	J38-3
2	Encoder 3 (ENCODER_2)	Input	Lane 3 Distribution Box	J38-5
3	Encoder 4 (ENCODER_3)	Input	Lane 4 Distribution Box	J36-5
4	Reject Container Full	Input	Correlation Sensor Box	J36-7
5	Door Open	Input	Correlation Sensor Box	J36-9
6	Part Detect 1 (PP_SENS_0)	Input	Lane 1 Distribution Box	J36-11
7	Part Detect 2 (PP_SENS_1)	Input	Lane 2 Distribution Box	J38-7
8	Part Detect 3 (PP_SENS_2)	Input	Lane 3 Distribution Box	J38-9
9	Part Detect 4 (PP_SENS_3)	Input	Lane 4 Distribution Box	J36-13
10	Transfer Arm Index (MACHINE PART 2)	Input	Correlation Sensor Box	J36-15
11	Spindle Index (POCKET DETECT 2)	Input	Correlation Sensor Box	J36-17
12	Cavity Index (MACHINE PART 1)	Input	Correlation Sensor Box	J36-19
13	Pocket Detect 1	Input	Correlation Sensor Box	J36-21
14	Reject Confirm 1 (REJ_CNFM_SENS_0)	Input	Lane 1 Distribution Box	J36-23
15	Reject Confirm 2 (REJ_CNFM_SENS_1)	Input	Lane 2 Distribution Box	J38-11
16	Reject Confirm 3 (REJ_CNFM_SENS_2)	Input	Lane 3 Distribution Box	J38-13
17	Reject Confirm 4 (REJ_CNFM_SENS_3)	Input	Lane 4 Distribution Box	J36-25
18	Unassigned (USER 6/ AUX INPUT)	Input	J14-6	J36-27
19	AC Power Failure (USER 5)	Input	Hard wired to power switch	J36-29
20	Unassigned	Input	n/c	
21	Over Temp	Input	Hard wired to thermostat	J36-31
22	Clear Alarms (IN1_ISOL) (CLR)	Input	TB1-37	J38-15

I/O number on screen	Signal	Type	Connection Point	Test Point
23	Unassigned (IN2_ISOL) (INB)	Input	TB1-38	J38-17
24	Activate Inputs #25, 26, 27 (IN3_ISOL)	Input	TB1-39	J38-19
25	Print Statistics (IN4_ISOL)	Input	TB1-40	J38-21
26	Reset Statistics (IN5_ISOL)	Input	TB1-41	J38-23
27	Print Indicator Values (IN6_ISOL)	Input	TB1-42	J38-25
28	Q1 (Hydro only) (IN7_ISOL)	Input	TB1-43	J38-27
29	Q2(Hydro only) (IN8_ISOL)	Input	TB1-44	J38-29
30	Unassigned (IN9_ISOL)	Input	TB1-45	J38-31
31	Unassigned (IN10_ISOL)	Input	TB1-46	J22-2
32	Channel 1 Reject (CNREJECT_0)	Output	Lane 1 Distribution Box	J36-51
33	Channel 2 Reject (CNREJECT_1)	Output	Lane 2 Distribution Box	J38-51
34	Channel 3 Reject (CNREJECT_2)	Output	Lane 3 Distribution Box	J38-53
35	Channel 4 Reject (CNREJECT_3)	Output	Lane 4 Distribution Box	J36-53
36	Part Good 1 (PG_0_OUT)	Output	TB1-47	J36-41
37	Part Good 2 (PG_1_OUT)	Output	TB1-48	J36-43
38	Part Good 3 (PG_2_OUT)	Output	TB1-49	J36-45
39	Part Good 4 (PG_3_OUT)	Output	TB1-50	J36-47
40	Part Complete 1 (IC_0_OUT)	Output	TB1-51	J38-33
41	Part Complete 2 (IC_1_OUT)	Output	TB1-52	J38-35
42	Part Complete 3 (IC_2_OUT)	Output	TB1-53	J38-37
43	Part Complete 4 (IC_3_OUT)	Output	TB1-54	J38-39
44	Fire Strobe 1	Output	Hard wired to Light Controller	J17-61, J17-63
45	Fire Strobe 2	Output	Hard wired to Light Controller	J17-45, J17-47
46	Fire Strobe 3	Output	Hard wired to Light Controller	J17-29, J17-31
47	Fire Strobe 4	Output	Hard wired to Light Controller	J17-13, J17-15
48	Programmable Alarm Output 1 (PROG_OUT_0)	Output	TB1-55	J38-41
49	Programmable Alarm Output 2 (PROG_OUT_1)	Output	TB1-56	J38-43

I/O number on screen	Signal	Type	Connection Point	Test Point
50	Programmable Alarm Output 3 (PROG_OUT_2)	Output	TB1-57	J38-45
51	Programmable Alarm Output 4 (PROG_OUT_3)	Output	TB1-58	J38-47
52	Lighting Reset	Output	Hard wired to Light Controller	J17-57, J17-59
53	Online Status (USER 1)	Output	Hard wired to Green light - Light Tree	J36-33
54	Visual Alarm (USER 2)	Output	Hard wired to Red light - Light Tree	J36-35
55	Audible Alarm (USER 3)	Output	Hard wired to horn - Light Tree	J36-37
56	Warning Indicator (USER 4)	Output	Hard wired to yellow light - Light Tree	J36-39
57	Watchdog	Output	Hard wired to Light Tree	J36-35 (blink)
58	Unassigned	Output		
59	Unassigned	Output		
60	Unassigned	Output		
61	System State (Online/ Offline) (OUT1_ISOL)	Output	TB1-59	J22-4
62	Part Present 1 (OUT2_ISOL)	Output	TB1-60	J22-6
63	Part Present 2 (OUT3_ISOL)	Output	TB1-61	J22-8
64	Part Present 3 (OUT4_ISOL)	Output	TB1-62	J22-10
65	Part Present 4 (OUT5_ISOL)	Output	TB1-63	J22-12
66	Group Output 1 (OUT6_ISOL)	Output	TB1-64	J22-14
67	Group Output 2 (OUT7_ISOL)	Output	TB1-65	J22-16
68	Group Output 3 (OUT8_ISOL)	Output	TB1-66	J22-18
69	Group Output 4* (OUT9_ISOL)	Output	TB1-67	J22-20
70	Group Output 5* (OUT10_ISOL)	Output	TB1-68	J22-22
71	Group Output 6* (OUT11_ISOL)	Output	TB1-69	J22-24
72	Group Output 7* (OUT12_ISOL)	Output	TB1-70	J22-26
73	Group Output 8* (OUT13_ISOL)	Output	TB1-71	J22-28
74	Group Output 9* (OUT14_ISOL)	Output	TB1-72	J22-30

I/O number on screen	Signal	Type	Connection Point	Test Point
75	Group Output 10* (OUT15_ISOL)	Output	TB1-12	J22-32
76	Group Output 11* (OUT16_ISOL)	Output	TB1-13	J22-34
77	Group Output 12* (OUT17_ISOL)	Output	TB1-14	J22-36
78	Group Output 13* (OUT18_ISOL)	Output	TB1-15	J22-38
79	Group Output 14* (OUT19_ISOL)	Output	TB1-16	J22-40
80	Group Output 15* (OUT20_ISOL)	Output	TB1-17	J22-42
81	Group Output 16* (OUT21_ISOL)	Output	TB1-18	J22-44
82	Programmable Alarm Output 5* (OUT22_ISOL)	Output	TB1-19	J22-46
83	Programmable Alarm Output 6* (OUT23_ISOL)	Output	TB1-20	J22-48
84	Programmable Alarm Output 7* (OUT24_ISOL)	Output	TB1-21	J22-50
85	Programmable Alarm Output 8* (OUT25_ISOL)	Output	TB1-22	J22-52
86	Unassigned (OUT26_ISOL)	Output	TB1-23	J22-54
87	Unassigned (OUT27_ISOL)	Output	TB1-24	J22-56

*Unassigned in software versions previous to 4.0.027

ULTRA I/O OPTION

The Ultra I/O option is provided as a kit and includes the components shown on the next few pages. All TB1 terminal references in the following chart refer to the terminal block on the Main I/O, rear.

- * input
- TB1 is on the Main I/O, Rack 1 is the most populated I/O rack
- All outputs are NPN-type

Terminal	Function	Terminal	Function	Terminal	Function
TB1-1	GND ISOL	TB1-43	Unassigned *	Rack 1 - 13	Group 29
TB1-2	GND ISOL	TB1-44	Unassigned *	Rack 1 - 14	Group 30
TB1-3	GND ISOL	TB1-45	Unassigned *	Rack 1 - 15	Group 31
TB1-4	GND ISOL	TB1-46	Unassigned *	Rack 1 - 16	Group 32
TB1-5	GND ISOL	TB1-47	Part Good Lane 1	Rack 1 - 17	Group 33

Terminal	Function	Terminal	Function	Terminal	Function
TB1-6	GND ISOL	TB1-48	Part Good Lane 2	Rack 1 - 18	Group 34
TB1-7	GND ISOL	TB1-49	Part Good Lane 3	Rack 1 - 19	Group 35
TB1-8	GND ISOL	TB1-50	Part Good Lane 4	Rack 1 - 20	Group 36
TB1-9	GND ISOL	TB1-51	Insp. Comp. Lane 1	Rack 1 - 21	Group 37
TB1-10	GND ISOL	TB1-52	Insp. Comp. Lane 2	Rack 1 - 22	Group 38
TB1-11	GND ISOL	TB1-53	Insp. Comp. Lane 3	Rack 1 - 23	Group 39
TB1-12	Group 10	TB1-54	Insp. Comp. Lane 4	Rack 1 - 24	Group 40
TB1-13	Group 11	TB1-55	Prog. Out 1	Rack 1 - 25	Group 41
TB1-14	Group 12	TB1-56	Prog. Out 2	Rack 1 - 26	Group 42
TB1-15	Group 13	TB1-57	Prog. Out 3	Rack 1 - 27	Group 43
TB1-16	Group 14	TB1-58	Prog. Out 4	Rack 1 - 28	Group 44
TB1-17	Group 15	TB1-59	System State	Rack 1 - 29	Group 45
TB1-18	Group 16	TB1-60	Part Pres. Lane 1	Rack 1 - 20	Group 46
TB1-19	Prog. Out 5	TB1-61	Part Pres. Lane 2	Rack 1 - 31	Group 47
TB1-20	Prog. Out 6	TB1-62	Part Pres. Lane 3	Rack 1 - 32	Group 48
TB1-21	Prog. Out 7	TB1-63	Part Pres. Lane 4	Rack 1 - 33	Group 49
TB1-22	Prog. Out 8	TB1-64	Group 1	Rack 1 - 34	Group 50
TB1-23	Unassigned	TB1-65	Group 2	Rack 1 - 35	Group 51
TB1-24	Unassigned	TB1-66	Group 3	Rack 1 - 36	Group 52
TB1-25	+24V ISOL	TB1-67	Group 4	Rack 1 - 37	Group 53
TB1-26	+24V ISOL	TB1-68	Group 5	Rack 1 - 38	Group 54
TB1-27	+24V ISOL	TB1-69	Group 6	Rack 1 - 39	Group 55
TB1-28	+24V ISOL	TB1-70	Group 7	Rack 1 - 40	Group 56
TB1-29	+24V ISOL	TB1-71	Group 8	Rack 1 - 41	Group 57
TB1-30	+24V ISOL	TB1-72	Group 9	Rack 1 - 42	Group 58
TB1-31	+24V ISOL	Rack 1 - 1	Group 17	Rack 1 - 43	Group 59
TB1-32	+24V ISOL	Rack 1 - 2	Group 18	Rack 1 - 44	Group 60
TB1-33	+24V ISOL	Rack 1 - 3	Group 19	Rack 1 - 45	Group 61
TB1-34	+24V ISOL	Rack 1 - 4	Group 20	Rack 1 - 46	Group 62
TB1-35	+24V ISOL	Rack 1 - 5	Group 21	Rack 1 - 47	Group 63
TB1-36	+24V ISOL	Rack 1 - 6	Group 22	Rack 1 - 48	Group 64
TB1-37	Clear *	Rack 1 - 7	Group 23	Rack 2 - 1	Part Not Proc. Lane 1
TB1-38	Unassigned *	Rack 1 - 8	Group 24	Rack 2 - 2	Part Not Proc. Lane 2
TB1-39	Activate *	Rack 1 - 9	Group 25	Rack 2 - 3	Part Not Proc. Lane 3

Terminal	Function	Terminal	Function	Terminal	Function
TB1-40	Print Stats*	Rack 1 - 10	Group 26	Rack 2 - 4	Part Not Proc. Lane 4
TB1-41	Reset Stats*	Rack 1 - 11	Group 27	Rack 1 - C	Tie to Cust. GND
TB1-42	Print Ind. Val.*	Rack 1 - 12	Group 28	Rack 2 -C	Tie to Cust. GND

Ultra I/O wiring 1 of 3

Ultra I/O wiring sheet 1 of 3

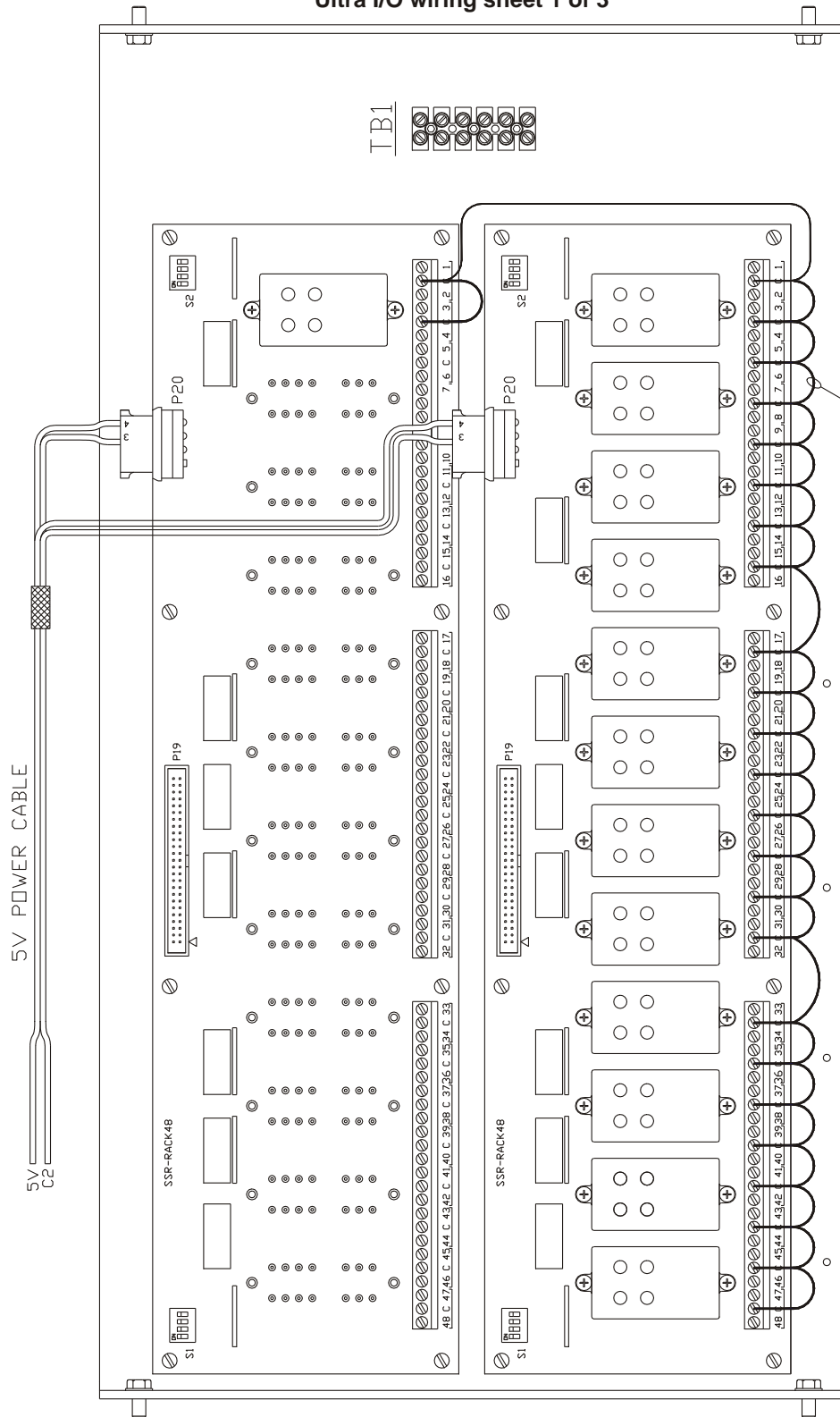

JUMPER ALL 'C' TERMINALS TOGETHER WITH 63481 BLUE WIRE.

NOTES:

- 1) SEE PAGE 2 FOR WIRING TO TB1.
- 2) CONNECT 5V POWER SUPPLY CABLE TO P20 OF EACH BOARD. (SEE PG 3 FOR POWER CABLE)

Ultra I/O wiring 2 of 3

Ultra I/O wiring sheet 2 of 3

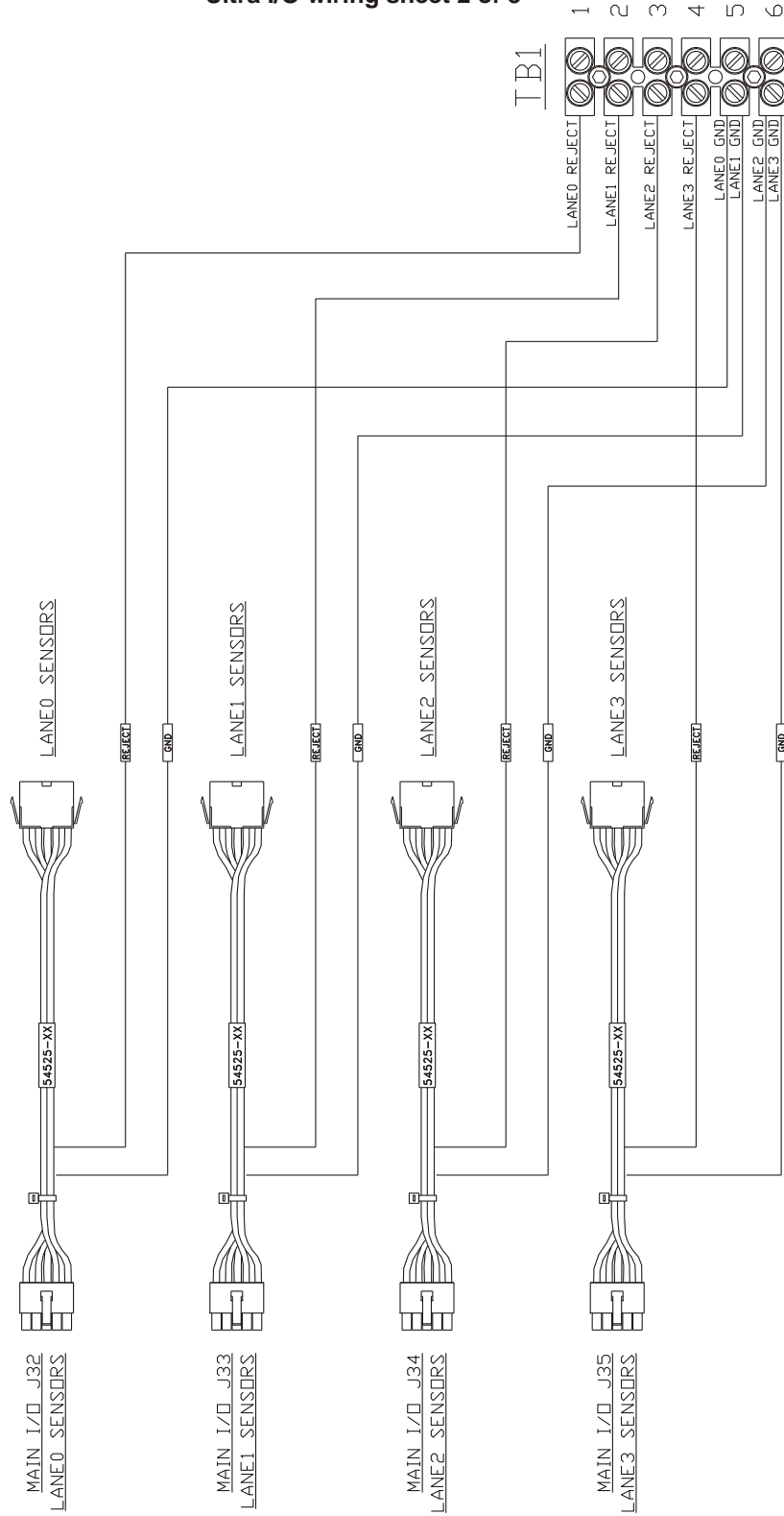

Ultra I/O wiring 3 of 3

Ultra I/O wiring sheet 3 of 3

POWER CABLES ARE INCLUDED WITH THE OPTO RACKS

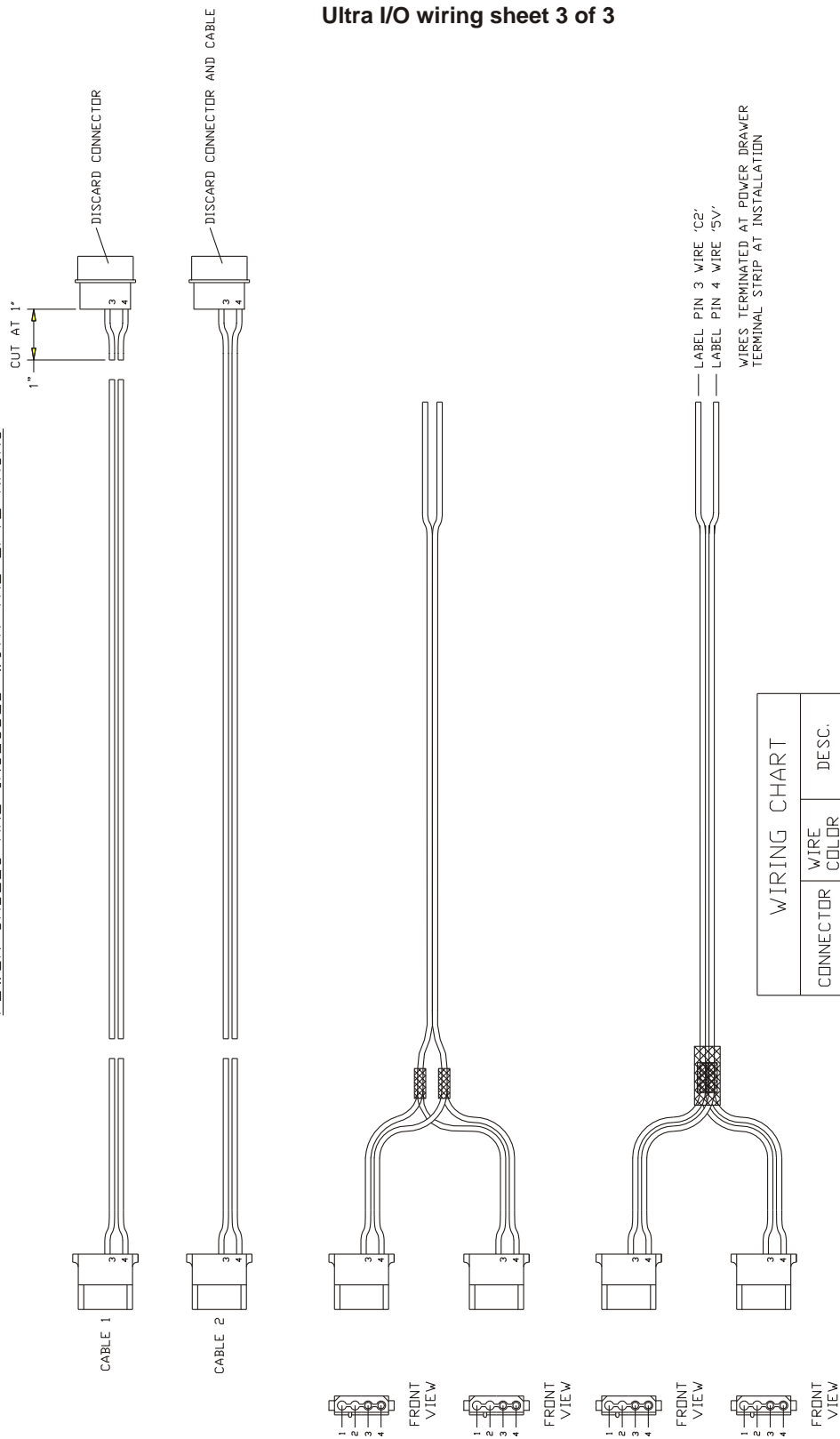

WIRING CHART		
CONNECTOR	WIRE COLOR	DESC.
1	-	-
2	-	-
3	BLACK	COM
4	RED	+5 VDC

Chapter 5

MAIN I/O BOARD SERIES IV-D

The Main I/O Board is mounted vertically to a support plate in the rear of the Processor Cabinet. The back side of the Main I/O Board provides input and output (I/O) communication with the System Computer and the UPS. The front of the board provides for communication with the visible/ audible alarm, the part position sensors, the encoder, the correlation sensors, and cameras. The sensor inputs and alarms are optically isolated; the vision system cameras are not.

The Main I/O board includes three daughter boards on the rear side: the Camera Personality Daughter Board and two Isolated I/O Daughter Boards.

The Camera Personality Daughter Board plugs into connector terminals J16 and J17 on the rear of the Main I/O Board. This board conditions the camera driver signals going out to the camera modules and the communication signals between the PRIO Board and the Image Acquisition Board.

The Isolated I/O Daughter Boards plug into connector terminals J36/J37 and J38/J39 on the Main I/O Board. This board uses optical isolators to isolate incoming part sensor signals, encoder signals, and actuator signals from the system electronic circuits. The Extended I/O isolation daughter board plugs into J21/J22 on the front of the Main I/O board. The Extended I/O signals are accessible on terminal strip TB1 on the *rear of the Main I/O* (see "Main I/O Board, Rear View" on page 45).

MAIN I/O IN SERIES IV-D

In Series IV-D systems, a jumper [55962 (see "Main I/O Daughter board pinouts 2" on page 58)] is installed across J16 on the Camera Personality Board. Additionally, shorting jumpers (55963) are installed on connectors J40-J43 (Frame Grabber connectors on rear of Main I/O board).

MAIN I/O BOARD, FRONT VIEW

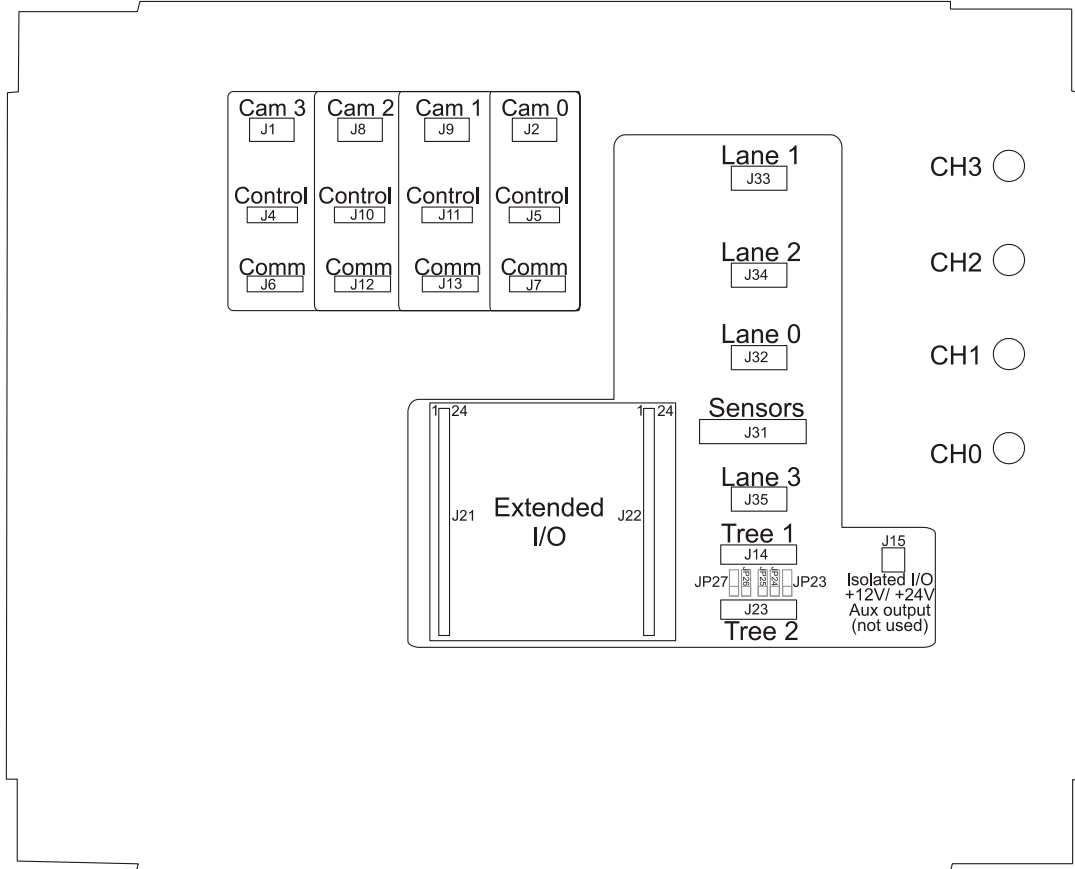

MAIN I/O BOARD, REAR VIEW

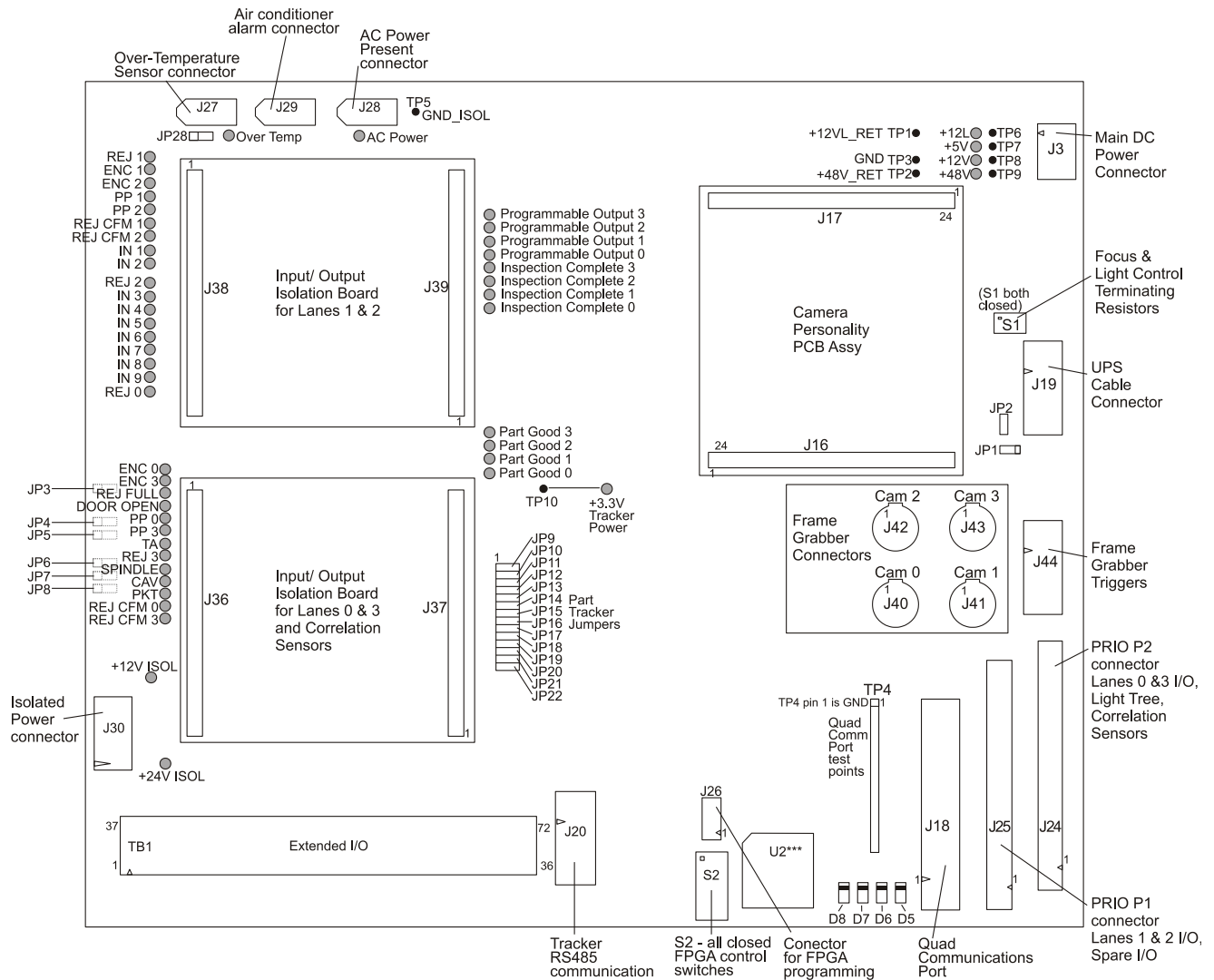

❖ *Note: In Series IV-D and IV-D+ systems, J40-J43 have shorting jumpers (55962) on them.*

***U2

Main I/O - U2 Horn Audible alarm part 52828 Version 02 used as of 5/31/2005. Version 01 chips need to be replaced, not re-programmed. This changes audible alarm (horn): If user programs audible alarm for extended or indefinite period, horn will now sound for one minute, then beep afterwards. It will no longer stay on continuously.

MAIN I/O JUMPER SETTINGS

Jumpers JP1 through JP28 have three pins each and are located on the Main I/O Board. These jumpers must be set properly for the correlation sensors and part tracker circuitry.

Referring to JP3 through JP8, when the jumper is set to 1-2, pin 4 of the *correlation sensors cable* (see "45906 cable 8 port distribution box internal" on page 181) is connected to the Isolated I/O Board. When the jumper is set to 2-3, pin 2 of the correlation sensors cable is connected to the Isolated I/O Board. Whether pin 2 or pin 4 is routed to the Isolated I/O Board depends on the type of sensor used.

Jumper	Description	Function	Default Setting
JP1	UPS port configuration	1-2: UPS port configuration	No jumper
JP2	UPS port configuration	1-2: UPS port configuration 2-3: UPS port configuration	No jumper
JP3	Reject Chute Full Sensor input	1-2: Sensor input on pin 4 of 4-pin connector 2-3: Sensor input on pin 2 of 4-pin connector	2 – 3
JP4	Reject Door Open	1-2: Sensor input on pin 4 of 4-pin connector 2-3: Sensor input on pin 2 of 4-pin connector	1 – 2
JP5	Transfer Arm Index (Machine Part 2*)	1-2: Sensor input on pin 4 of 4-pin connector 2-3: Sensor input on pin 2 of 4-pin connector	1 – 2
JP6	Spindle Index (Pocket Detect 2)	1-2: Sensor input on pin 4 of 4-pin connector 2-3: Sensor input on pin 2 of 4-pin connector	1 – 2
JP7	Cavity Index (Machine Part 1)	1-2: Sensor input on pin 4 of 4-pin connector 2-3: Sensor input on pin 2 of 4-pin connector	2 – 3 (1 – 2)
JP8	Pocket Detect (Pocket Detect 1)	1-2: Sensor input on pin 4 of 4-pin connector 2-3: Sensor input on pin 2 of 4-pin connector	1 – 2
JP9	Cavity Index Sensor Input Configuration	1-2: Input to PRIO 2-3: Input to Part Tracker then to PRIO	1 – 2
JP10	Spindle Index Sensor Input Configuration	1-2: Input to PRIO 2-3: Input to Part Tracker then to PRIO	1 – 2
JP11	Transfer Arm Index Sensor Input Configuration	1-2: Input to PRIO 2-3: Input to Part Tracker then to PRIO	1 – 2
JP12	Spare Input 11 Configuration	1-2: Input to PRIO 2-3: Input to Part Tracker then to PRIO	1 – 2
JP13	Pocket Detect Sensor Input Configuration	1-2: Input to PRIO 2-3: Input to Part Tracker then to PRIO	1 – 2
JP14	Lane 0 Part Present Input Configuration	1-2: Input to PRIO 2-3: Input to Part Tracker then to PRIO	1 – 2
JP15	Lane 3 Part Present Input Configuration	1-2: Input to PRIO 2-3: Input to Part Tracker then to PRIO	1 – 2
JP16	Lane 0 Reject Output Configuration	1-2: Output from PRIO to Rejecter 2-3: Output from PRIO to Part Tracker to Rejecter	1 – 2

Jumper	Description	Function	Default Setting
JP17	Spare Input 10 Configuration	1-2: Input to PRIO 2-3: Input to Part Tracker then to PRIO	1 – 2
JP18	Spare Input 9 Configuration	1-2: Input to PRIO 2-3: Input to Part Tracker then to PRIO	1 – 2
JP19	Spare Input 8 Configuration	1-2: Input to PRIO 2-3: Input to Part Tracker then to PRIO	1 – 2
JP20	Lane 0 Encoder Input Configuration	1-2: Input to PRIO 2-3: Input to Part Tracker then to PRIO	1 – 2
JP21	Lane 3 Encoder Input Configuration	1-2: Input to PRIO 2-3: Input to Part Tracker then to PRIO	1 – 2
JP22	Lane 3 Reject Output Configuration	1-2: Output from PRIO to Rejecter 2-3: Output from PRIO to Part Tracker to Rejecter	1 – 2
JP23	Intellispec Light Tree Blue Lamp Output	1-2: Output from PRIO 2-3: Output from PRIO or Part Tracker	1 – 2
JP24	Intellispec Light Tree Yellow Lamp Output	1-2: Output from PRIO 2-3: Output from PRIO or Part Tracker	1 – 2
JP25	Intellispec Light Tree Horn Output	1-2: Output from PRIO 2-3: Output from PRIO or Part Tracker	1 – 2
JP26	Intellispec Light Tree Red Lamp Output	1-2: Output from PRIO 2-3: Output from PRIO or Part Tracker	1 – 2
JP27	Intellispec Light Tree Green Lamp Output	1-2: Output from PRIO 2-3: Output from PRIO or Part Tracker	1 – 2
JP28	Air Conditioner Alarm Configuration	1-2: Alarm kit not installed 2-3: Alarm kit installed	1 – 2

(*Names and settings in parentheses are for two-lane correlation)

MAIN I/O SWITCH SETTINGS

Dip switch S1 places a termination resistor on the end of the RS-485 Lighting and Focus Control Networks. When needed, shorting plugs (Pressco P/N 46244) connect to terminals J6, J12, and/or J13 to jumper out missing camera modules.

The RS-485 Lighting and Focus Control networks originate on the 4-Port Serial Board and connect by cable to the Main I/O Board. From the Main I/O Board, the networks are daisy-chained to the camera lighting modules.

The Lighting and Focus Control Network S1 dip switch settings, positions 1 and 2, are both closed. Connectors J6, J7, J12 and J13 should be connected with the standard mating connector or have the shorting plugs (46244) installed.

Refer to the *Main I/O Board rear view* (see "Main I/O Board, Rear View" on page 45) for the locations of S1 and S2. Refer to the Main I/O Board front view for the locations of J6, J7, J12, and J13.

Switch	Default	Description	Function
S1 (2 position)	All Closed	RS485 termination	Light and focus control termination resistors
S2 (8 position)	All Closed	Strobe Trigger Mode	Strobes can be triggered by more than one channel

Mode	Main I/O Switch S2								To Inspection Module 0	To Inspection Module 1	To Inspection Module 2	To Inspection Module 3
	1	2	3	4	5	6	7	8	Module 0	Module 1	Module 2	Module 3
1	0	0	0	0	0	0	0	0	Fire_strobe_0	Fire_strobe_1	Fire_strobe_2	Fire_strobe_3
2	1	0	0	0	0	0	0	0	Fire_strobe_0 or 1	Fire_strobe_1	Fire_strobe_2	Fire_strobe_3
3	0	1	0	0	0	0	0	0	Fire_strobe_0	Fire_strobe_1	Fire_strobe_2 or 3	Fire_strobe_3
4	1	1	0	0	0	0	0	0	Fire_strobe_0 or 2	Fire_strobe_1	Fire_strobe_2	Fire_strobe_3
5	0	0	1	0	0	0	0	0	Fire_strobe_0 or 1 or 2	Fire_strobe_1	Fire_strobe_2	Fire_strobe_3
6	1	0	1	0	0	0	0	0	Fire_strobe_0 or 1 or 2 or 3	Fire_strobe_1	Fire_strobe_2	Fire_strobe_3
7	0	1	1	0	0	0	0	0	Fire_strobe_0 or 1	Fire_strobe_1	Fire_strobe_2 or 3	Fire_strobe_3
8	1	1	1	0	0	0	0	0	Fire_strobe_0	Fire_strobe_1 or 2	Fire_strobe_2	Fire_strobe_3

NOTES:

- 0=Closed (down); 1=Open (up)
- Mode 1 - Normal Mode - each Channel triggers own array
- Mode 2 - Channels 0 or 1 trigger Channel 0 array; Channels 2, 3 normal
- Mode 3 - Channels 2 or 3 trigger Channel 2 array; Channels 0, 1 normal
- Mode 4 - Channels 0 or 2 trigger Channel 0 array; Channels 1, 3 normal
- Mode 5 - Channels 0, 1 or 2 trigger Channel 0 array; Channel 3 normal
- Mode 6 - All Channels trigger Channel 0 array
- Mode 7 - Channels 0 or 1 trigger Channel 0 array; Channels 2 or 3 trigger Channel 2 array
- Mode 8 - Channels 1 or 2 trigger Channel 1 array; Channels 0, 3 normal
- Mode 1 = any other switch setting different from above

MAIN I/O BOARD LEDS AND TEST POINTS

LED Label	Signal	Comments	Default
+12L	+12 Vdc Linear	+12 Vdc Camera power supply	ON
+12V	+12Vdc	+12Vdc Electronics power supply	ON
+12V_ISO	+12 Vdc Isolated	+12 Vdc Isolated I/O power supply	ON
+24V_ISO	+24 Vdc Isolated	+24 Vdc Isolated I/O power supply for system encoders, sensors, and actuators	ON
+3.3V	+3.3Vdc	+3.3Vdc power supply for Tracker board (Vreg U3)	ON
+48V	+48 Vdc	+48 Vdc Light Array power supply	ON
+5V	+5 Vdc	+5 Vdc Electronics power supply	ON
AC PWR	Power Status	The processor monitors the Main AC Power Switch status. If the Main AC Power Switch is turned off while the system is otherwise powered up, an AC Fail input is sent to the computer and a warning is initiated.	ON
CAV	Cavity Index	Pulse from Cavity sensor – used in systems with correlation. Alternate label is Machine Part 1 . Signal routed through 8 port I/O box.	OFF
DO	Door Open	Used mainly in blow molder applications. LED lights when blow molder door is open. The Blow Molder Door alarm is triggered (if enabled).	OFF
ENC0	Encoder, Lane 0	Flashes/lights when channel 0 encoder is running	OFF
ENC1	Encoder, Lane 1	Flashes/lights when channel 1 encoder is running	OFF
ENC2	Encoder, Lane 2	Flashes/lights when channel 2 encoder is running	OFF
ENC3	Encoder, Lane 3	Flashes/lights when channel 3 encoder is running	OFF
IC 0	Inspection Complete, Lane 0	Flashes/lights when a part through channel 0 completes the inspection process. Duration of pulse = Complete Pulse Width on Tracking tab under System Configuration Channel Groups	OFF
IC 1	Inspection Complete, Lane 1	Flashes/lights when a part through channel 1 completes the inspection process. Duration of pulse = Complete Pulse Width on Tracking tab under System Configuration Channel Groups	OFF
IC 2	Inspection Complete, Lane 2	Flashes/lights when a part through channel 2 completes the inspection process. Duration of pulse = Complete Pulse Width on Tracking tab under System Configuration Channel Groups	OFF
IC 3	Inspection Complete, Lane 3	Flashes/lights when a part through channel 3 completes the inspection process. Duration of pulse = Complete Pulse Width on Tracking tab	OFF

LED Label	Signal	Comments	Default
		under System Configuration Channel Groups	
IN 1 (Isolated Inputs)	Clear Alarms (CLR)	Flashes/lights when this input is activated. It clears all active alarms.	OFF
IN 2	Unassigned (INB)		OFF
IN 3	Activate Inputs (for IN4, IN5, IN6)	Flashes/lights when this input is activated. It alerts the software to read the status of the Print Statistics, Reset Statistics, and Print Indicator Value inputs and take appropriate action.	OFF
IN 4	Print Statistics	Flashes/lights when this input is activated. It initiates a print of the current job statistics. Input IN 3 must be activated concurrently.	OFF
IN 5	Reset Statistics	Flashes/lights when this input is activated. It resets the current job statistics. Input IN 3 must be activated concurrently.	OFF
IN 6	Print Indicator Values	Flashes/lights when this input is activated. It prints a report for each active indicator value for all currently running inspections. Input IN 3 must be activated concurrently.	OFF
IN 7	Q1 (Multi-void tube applications only)	Q1 is a qualifying signal sent from the Shell to the PRIO. Q1 is active for fake part detects that are generated for middle views of the system part.	OFF
IN 8	Q2 (Multi-void tube applications only)	Q2 is a qualifying signal sent from the Shell to the PRIO. Q2 is active for fake part detects that are generated for trailing edge views of the system part.	OFF
IN 9	Unassigned		OFF
OT	High Temp	If the internal Processor Cabinet temperature exceeds a high limit, a temperature sensor sends an Over-temperature signal to the computer to initiate a fault warning. In the event of an over-temperature warning, the Intellispec System must be powered down to cool off and clear the warning.	ON
PG 0	Part Good, Lane 0	Flashes/lights when a part through channel 0 passes inspection. Duration = Pass Pulse Width on Tracking tab under System Configuration Channel Groups	OFF
PG 1	Part Good, Lane 1	Flashes/lights when a part through channel 1 passes inspection. Duration = Pass Pulse Width on Tracking tab under System Configuration Channel Groups	OFF
PG 2	Part Good, Lane 2	Flashes/lights when a part through channel 2 passes inspection. Duration = Pass Pulse Width on Tracking tab under System Configuration Channel Groups	OFF
PG 3	Part Good, Lane 3	Flashes/lights when a part through channel 3 passes inspection. Duration = Pass Pulse Width	OFF

LED Label	Signal	Comments	Default
		on Tracking tab under System Configuration Channel Groups	
PKT	Pocket Detect	Pulse from Pocket Detect sensor – used in systems with correlation. Alternate label is Pocket Detect 1 . Signal routed through 8 port I/O box.	OFF
PO 0	Programmable Output 0	Programmable Alarm Output 1 in software. LED lights when any assigned alarm is triggered. (Intellispec 3.1 & later)	OFF
PO 1	Programmable Output 1	Programmable Alarm Output 2 in software. LED lights when any assigned alarm is triggered. (Intellispec 3.1 & later)	OFF
PO 2	Programmable Output 2	Programmable Alarm Output 3 in software. LED lights when any assigned alarm is triggered. (Intellispec 3.1 & later)	OFF
PO 3	Programmable Output 3	Programmable Alarm Output 4 in software. LED lights when any assigned alarm is triggered. (Intellispec 3.1 & later)	OFF
PP 0	Part Present, Lane 0	Flashes/lights when channel 0 part present sensor detects parts	OFF
PP 1	Part Present, Lane 1	Flashes/lights when channel 1 part present sensor detects parts	OFF
PP 2	Part Present, Lane 2	Flashes/lights when channel 2 part present sensor detects parts	OFF
PP 3	Part Present, Lane 3	Flashes/lights when channel 3 part present sensor detects parts	OFF
RC 0	Reject Confirm, Lane 0	Flashes/lights when channel 0 detects that a part was rejected. Active after original reject pulse width + confirm delay. Optional feature – requires additional hardware.	OFF
RC 1	Reject Confirm, Lane 1	Flashes/lights when channel 1 detects that a part was rejected. Active after original reject pulse width + confirm delay. Optional feature – requires additional hardware.	OFF
RC 2	Reject Confirm, Lane 2	Flashes/lights when channel 2 detects that a part was rejected. Active after original reject pulse width + confirm delay. Optional feature – requires additional hardware.	OFF
RC 3	Reject Confirm, Lane 3	Flashes/lights when channel 3 detects that a part was rejected. Active after original reject pulse width + confirm delay. Optional feature – requires additional hardware.	OFF
REJ 0	Reject, Lane 0	Flashes/lights when channel 0 rejects a part.	OFF
REJ 1	Reject, Lane 1	Flashes/lights when channel 1 rejects a part.	OFF
REJ 2	Reject, Lane 2	Flashes/lights when channel 2 rejects a part.	OFF
REJ 3	Reject, Lane 3	Flashes/lights when channel 3 rejects a part.	OFF

LED Label	Signal	Comments	Default
RF	Reject Full	Used mainly in blow molder applications. Lights when the reject bin is full. The Chute Full alarm is triggered (if enabled).	OFF
SP	Spindle Index	Pulse from Spindle sensor – used in systems with correlation. Alternate label is Pocket Detect 2 . Signal routed through 8 port I/O box.	OFF
TA	Transfer Arm Index	Pulse from Transfer Arm sensor – used in systems with correlation. Alternate label is Machine Part 2 . Signal routed through 8 port I/O box.	OFF
Label	Ground Test Point	Comments	
+12L_RET	TP1	+12 Vdc Linear ground (return line) for camera modules	
+48V_RET	TP2	+48 Vdc ground (return line) for lighting arrays	
GND	TP3 on Main I/O Bd, TP1 on Cam. Pers. Bd, TP1 on Isolated I/O Bd	+5/ +12 Vdc Electronics power supply return	
GND_ISOL	TP5 on Main I/O Bd, TP2 on Isolated I/O Bd	+12V/ +24Vdc Isolated I/O power supply return	
Label	Test Point	Comments	
	TP4	Quad serial card signal test points	
+12L	TP6	+12 V dc Linear for camera modules	
+5V	TP7	+5Vdc supplied to Main I/O board	
+12V	TP8	+12Vdc supplied to the camera module electronic circuits	
+48V	TP9	+48Vdc for inspection module lighting array LEDs	
+3.3V	TP10	+3.3V Part Tracker Power	

Camera and Lighting Signals

Signal	*Location	Comments
ASYNC_RESET_X	Camera Personality Bd	Should be at part rate; check camera personality board and cables if not.
+ASYNC_RESET_X	Camera Personality Bd	Should be at part rate; check camera personality board and cables if not.
-ASYNC_RESET_X	Camera Personality Bd	Should be at part rate; check camera personality board and cables if not.

Signal	*Location	Comments
FRESET_X	Camera Personality Bd	Should be at part rate; check cables if not.
LIGHT_RESET	PRIO Bd	Check PRIO or cables if missing. This signal occurs only on startup or if turned on using the Diagnostics Tools I/O I/O testing application.
+STROBE_RESET_X	Camera Personality Bd	Check camera personality board if missing.
-STROBE_RESET_X	Camera Personality Bd	Check camera personality board if missing.
+STROBE_TRIG_X	Camera Personality Bd	Should be at part rate; check camera personality board and cables if not.
-STROBE_TRIG_X	Camera Personality Bd	Should be at part rate; check camera personality board and cables if not.
STROBE_X	Main I/O FPGA	Should be at part rate; check main I/O FPGA U2 if not.
TRIGGER_FG_X	Camera Personality Bd	Should be at part rate; check camera personality board and cables if not.
TRIGGER_X	PRIO Bd	Should be at part rate; check PRIO or cables if not.
FIRE_STROBE_X	PRIO Bd	Should be at part rate; check PRIO or cables if not.

*Signal test points are shown in the following tables.

Signals Available for Checking

Signal reference designators (J17-49, etc.) are located on the Main I/O Board.

Camera Personality Signals to Camera Modules	
+ASYNCH_RESET_0	J17-49
-ASYNCH_RESET_0	J17-51
+ASYNCH_RESET_1	J17-33
-ASYNCH_RESET_1	J17-35
+ASYNCH_RESET_2	J17-17
-ASYNCH_RESET_2	J17-19
+ASYNCH_RESET_3	J17-1
-ASYNCH_RESET_3	J17-3
+STROBE_RESET_0	J17-57
-STROBE_RESET_0	J17-59
+STROBE_RESET_1	J17-41
-STROBE_RESET_1	J17-43
+STROBE_RESET_2	J17-25
-STROBE_RESET_2	J17-27
+STROBE_RESET_3	J17-9

-STROBE_RESET_3	J17-11
+STROBE_TRIG_0	J17-61
-STROBE_TRIG_0	J17-63
+STROBE_TRIG_1	J17-45
-STROBE_TRIG_1	J17-47
+STROBE_TRIG_2	J17-29
-STROBE_TRIG_2	J17-31
+STROBE_TRIG_3	J17-13
-STROBE_TRIG_3	J17-15

PRIO SIGNALS TEST POINTS

Signal reference designators (J17-49, etc.) are located on the Main I/O Board.

PRIO Signals	
ASYNCH_RESET_0	J16-45
ASYNCH_RESET_1	J16-51
ASYNCH_RESET_2	J16-57
ASYNCH_RESET_3	J16-63
LIGHT_RESET	J16-39
FIRE_STROBE_0	J16-31
FIRE_STROBE_1	J16-33
FIRE_STROBE_2	J16-35
FIRE_STROBE_3	J16-37
TRIGGER_0	J16-41
TRIGGER_1	J16-47
TRIGGER_2	J16-53
TRIGGER_3	J16-59
AC_FAIL	J37-29
CAV_INDX	J37-19
DOOROPEN	J37-9
ENCIN_0	J37-3
ENCIN_1	J39-3
ENCIN_2	J39-5
ENCIN_3	J37-5
ONLINE_STAT	J37-33
USER6/ AUX INPUT	J37-27
PPIN_0	J37-11

PRIO Signals	
PPIN_1	J39-7
PPIN_2	J39-9
PPIN_3	J37-13
PKT_DET	J37-21
REJECT_0	J37-51
REJECT_1	J39-51
REJECT_2	J39-53
REJECT_3	J37-53
REJ_CNFM_0	J37-23
REJ_CNFM_1	J39-11
REJ_CNFM_2	J39-13
REJ_CNFM_3	J37-25
REJFULL	J37-7
SP_INDX	J37-17
TA_INDX	J37-15
WARNING_IND	J37-37

CAMERA SIGNALS TEST POINTS

Signal test point on jumper **55962** (see "Main I/O Daughter board pinouts 2" on page 58) located on camera personality board.

Camera Signals	
Camera Trigger 0	pins 12, 25
Camera Trigger 1	pins 9, 24
Camera Trigger 2	pins 6, 23
Camera Trigger 3	pins 3, 22

COMMUNICATION PORT TEST POINTS

Signal reference designators (J17-49, etc.) are located on the Main I/O Board.

Communication port test points	
FC_485_TXD+	TP4-20
FC_485_TXD-	TP4-19
LC_485_TXD+	TP4-18
LC_485_TXD-	TP4-17
AWL_232_CTS	TP4-16

Communication port test points	
AWL_232_RXD	TP4-15
AWL_232_DTR	TP4-14
AWL_232_DSR	TP4-13
AWL_232_TXD	TP4-12
UPS_232_RI	TP4-11
UPS_232_DTR UPS Shutdown - to UPS	TP4-10
UPS_232_DSR	TP4-9
UPS_232_RTS	TP4-8
UPS_232_TXD	TP4-7
UPS_232_DCD UPS low battery - from UPS	TP4-6
UPS_232_CTS UPS power failure - from UPS	TP4-5
UPS_232_RXD	TP4-4

MAIN I/O DAUGHTER BOARD PINOUTS

Main I/O Daughter Boards Series IV

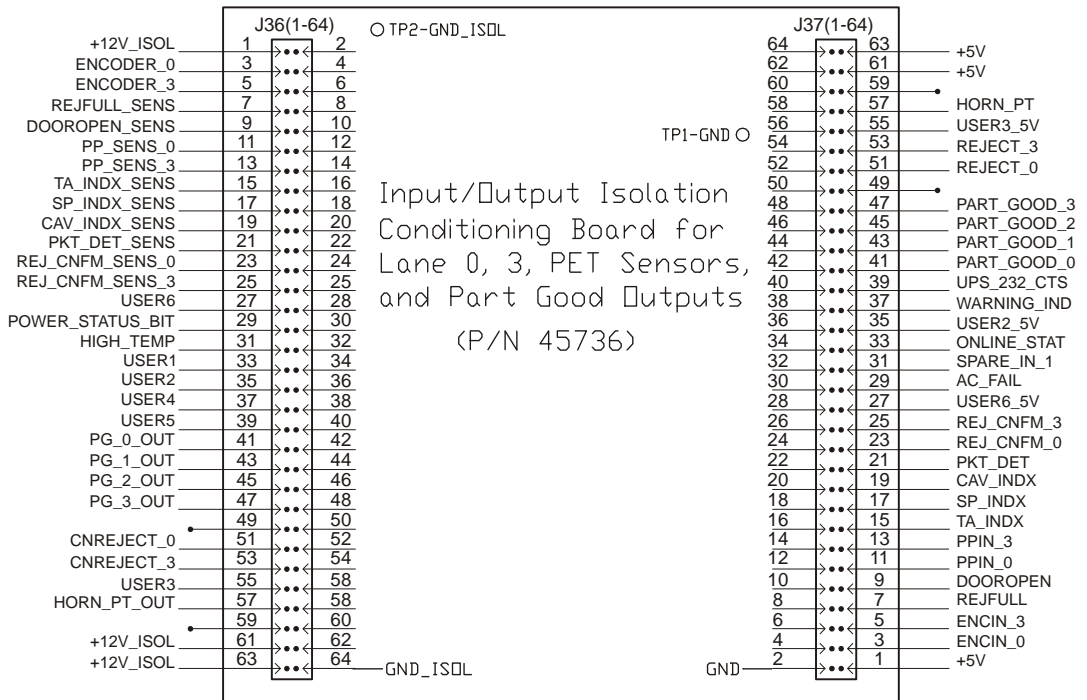
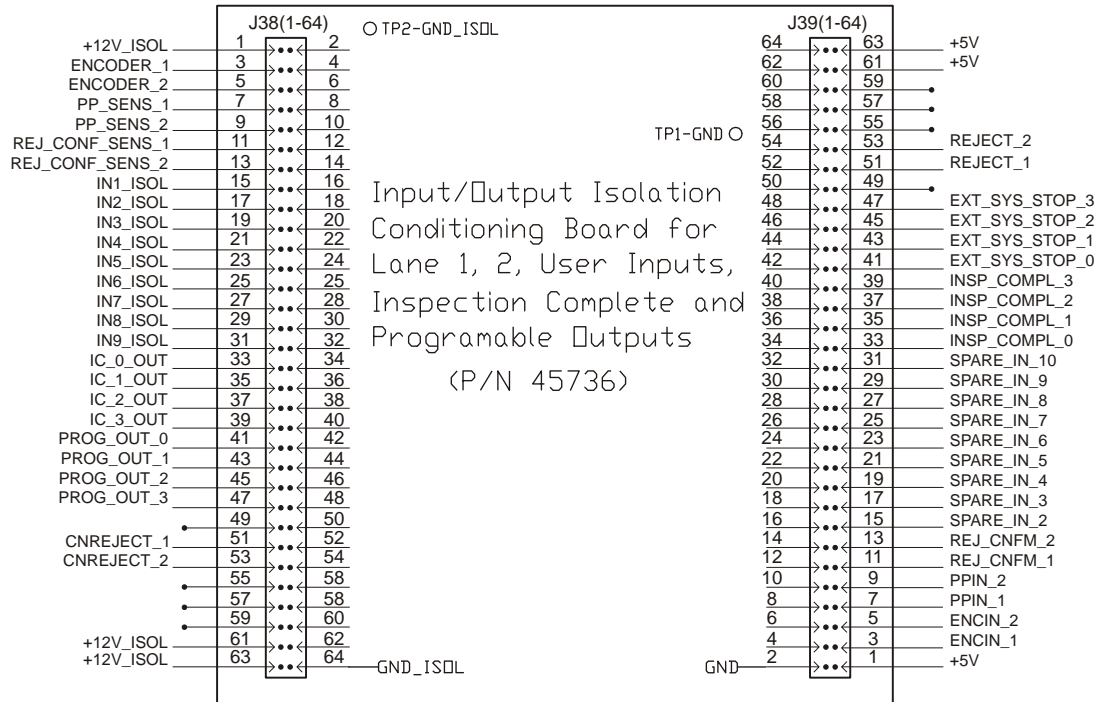

MAIN I/O DAUGHTER BOARD PINOUTS 2

Main I/O Daughter Boards Series IV

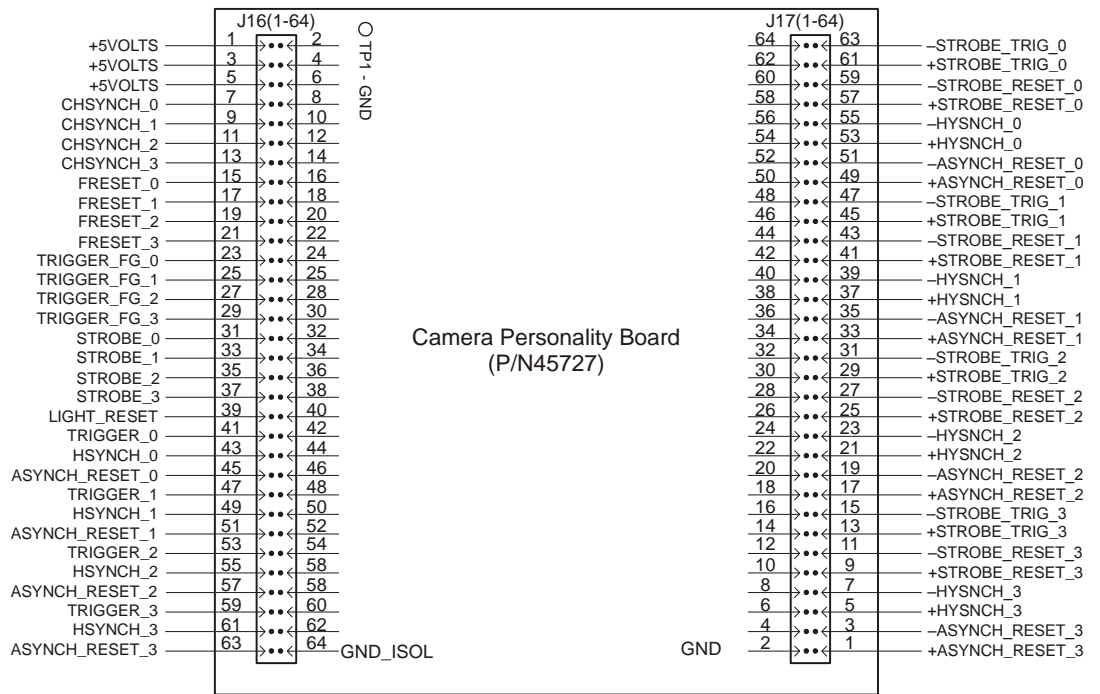

Series IV-D only jumper 55962

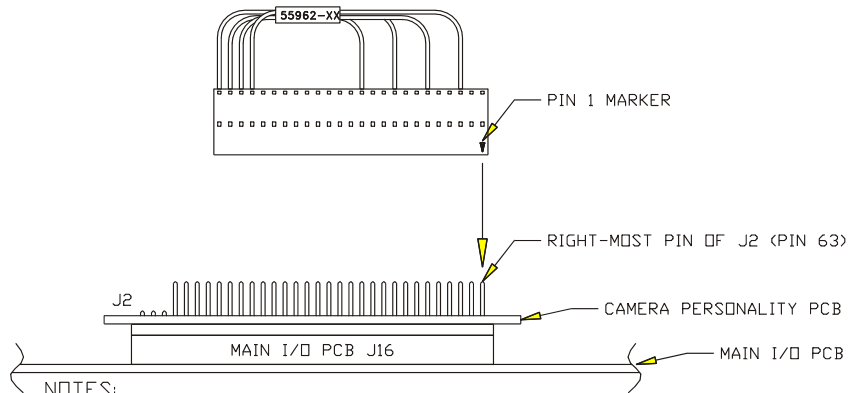

NOTES:

1) ALIGN JUMPER PIN 1 WITH RIGHT-MOST PIN OF CAMERA PERSONALITY PCB J2.

CAMERA PERSONALITY PCB JUMPED SIGNALS

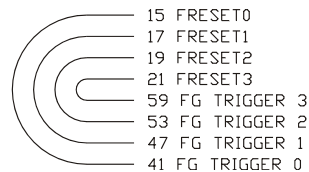

55962 JUMPERS

- PIN 3-22 - CAMERA TRIGGER 3
- PIN 6-23 - CAMERA TRIGGER 2
- PIN 9-24 - CAMERA TRIGGER 1
- PIN 12-25 - CAMERA TRIGGER 0

EXTENDED I/O DAUGHTER BOARD PINOUTS

Extended I/O daughter board 52838

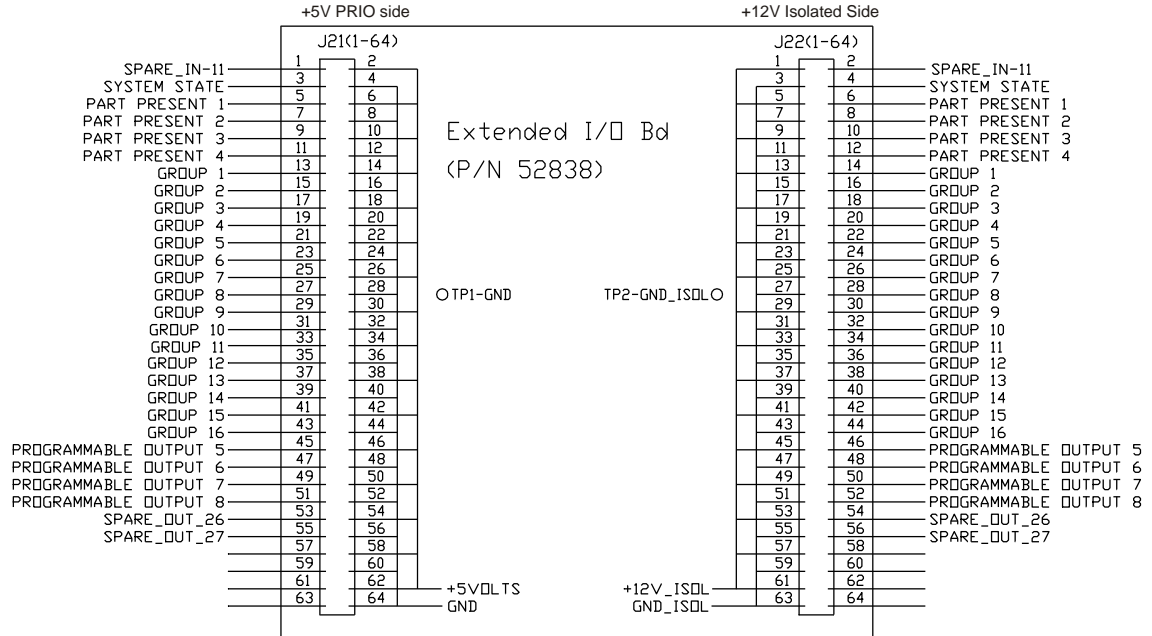

Extended I/O terminal block TB1

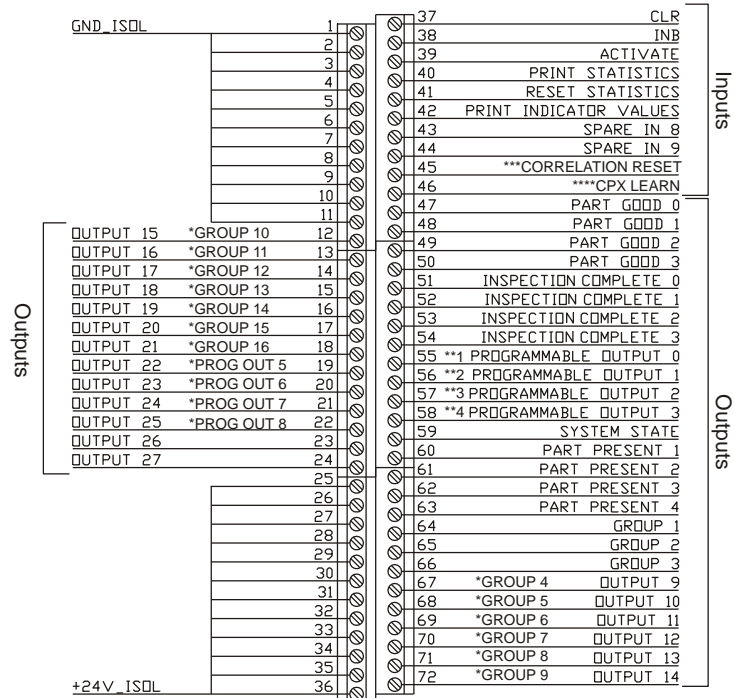

*Available with software version 4.0.027 and later
 **Alarms Programmable Outputs labeled 1-8 in software
 ***Available with software version 4.5.xxx and later
 ****Available with software version 4.6.xxx and later

Chapter 6

WIRING DIAGRAMS - PROCESSOR CABINET S IV-D, D+

CABINET COMPONENTS S IV-D

VIEW FROM CABINET FRONT

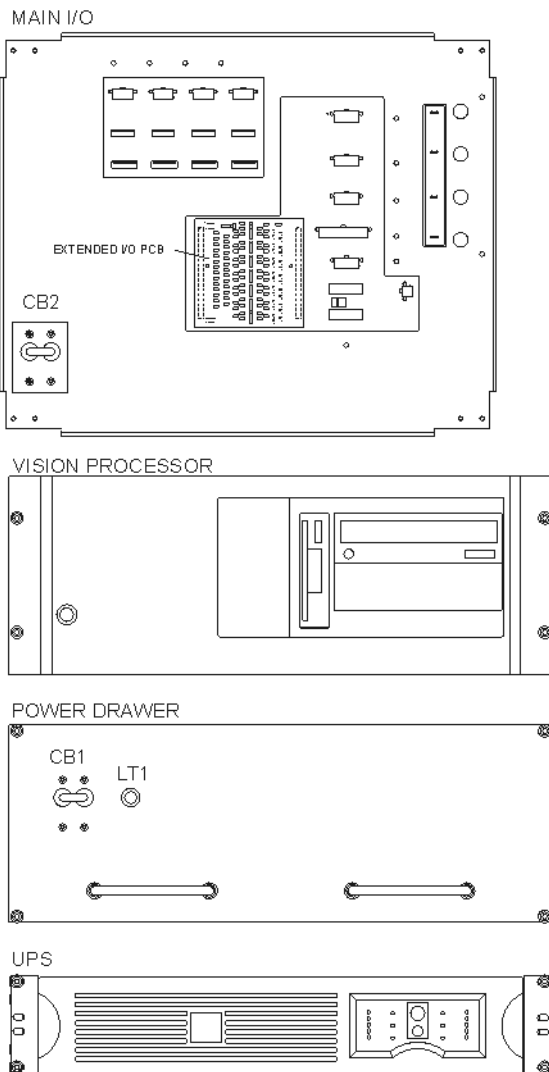

POWER CONNECTIONS S IV-D

VIEW FROM CABINET REAR

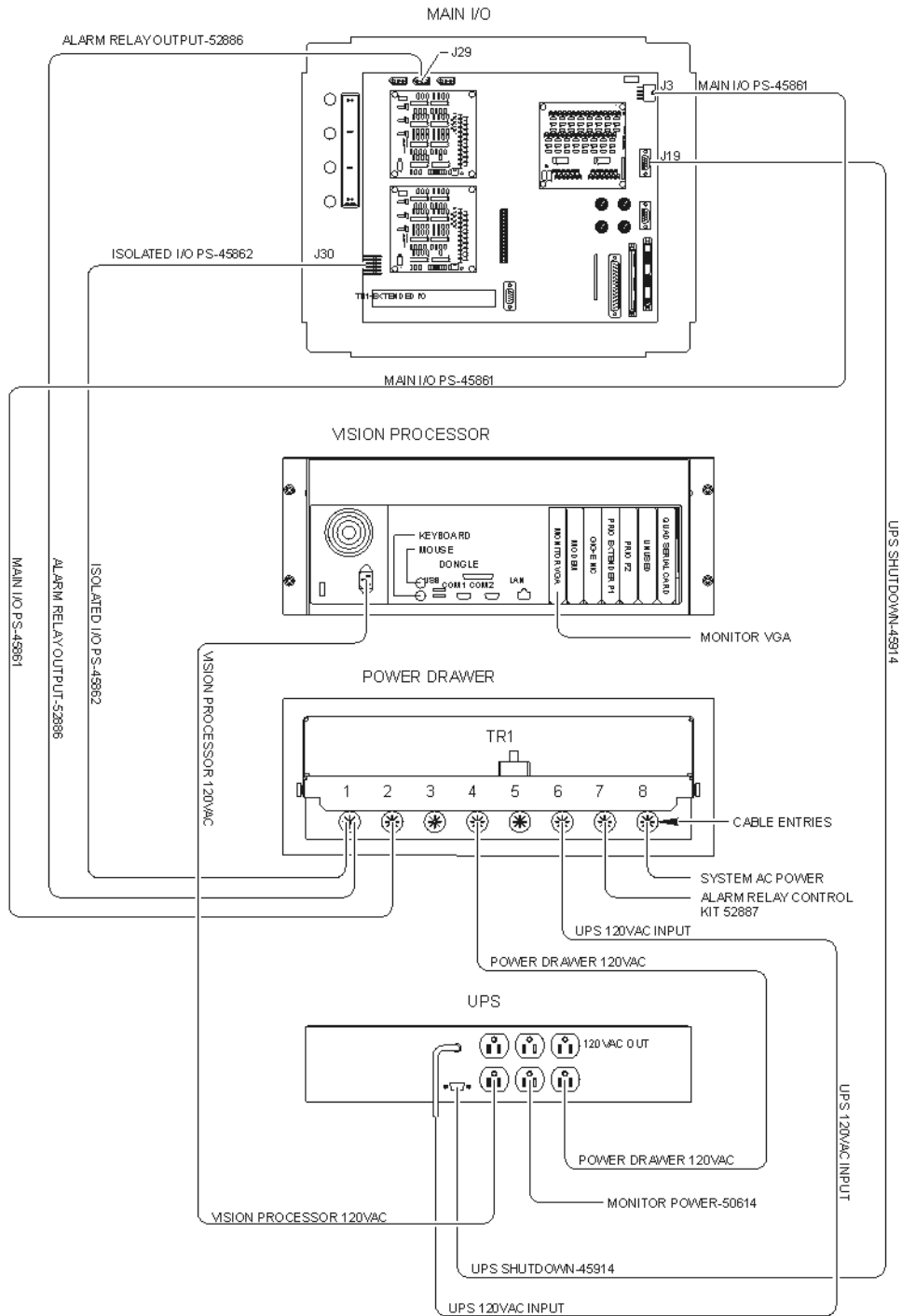

MAIN I/O CONNECTIONS S IV-D

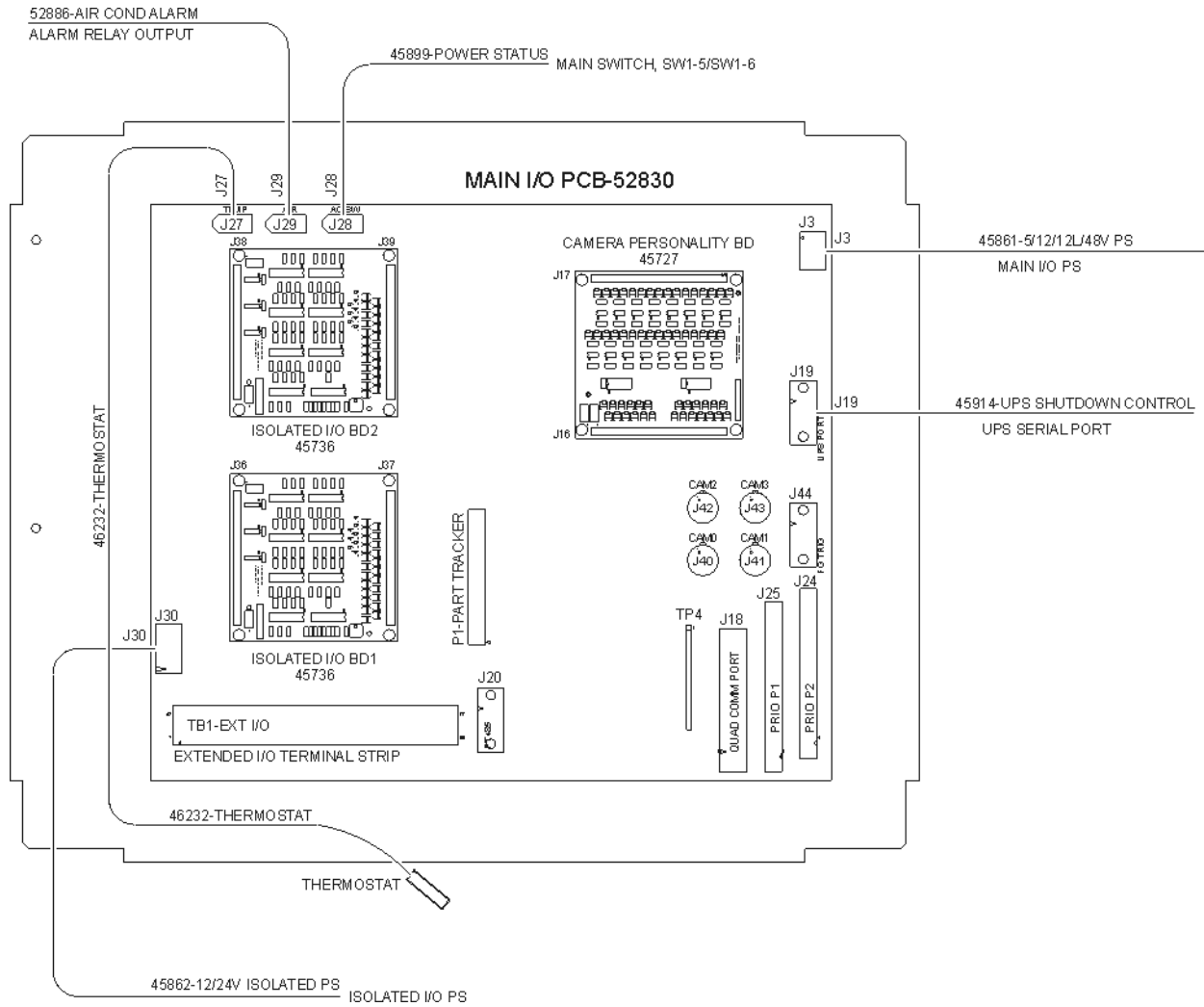

GLAND PLATE CONNECTIONS S IV-D

GLANDPLATE-INSIDE CABINET VIEW
SOME DETAILS REMOVED FOR CLARITY

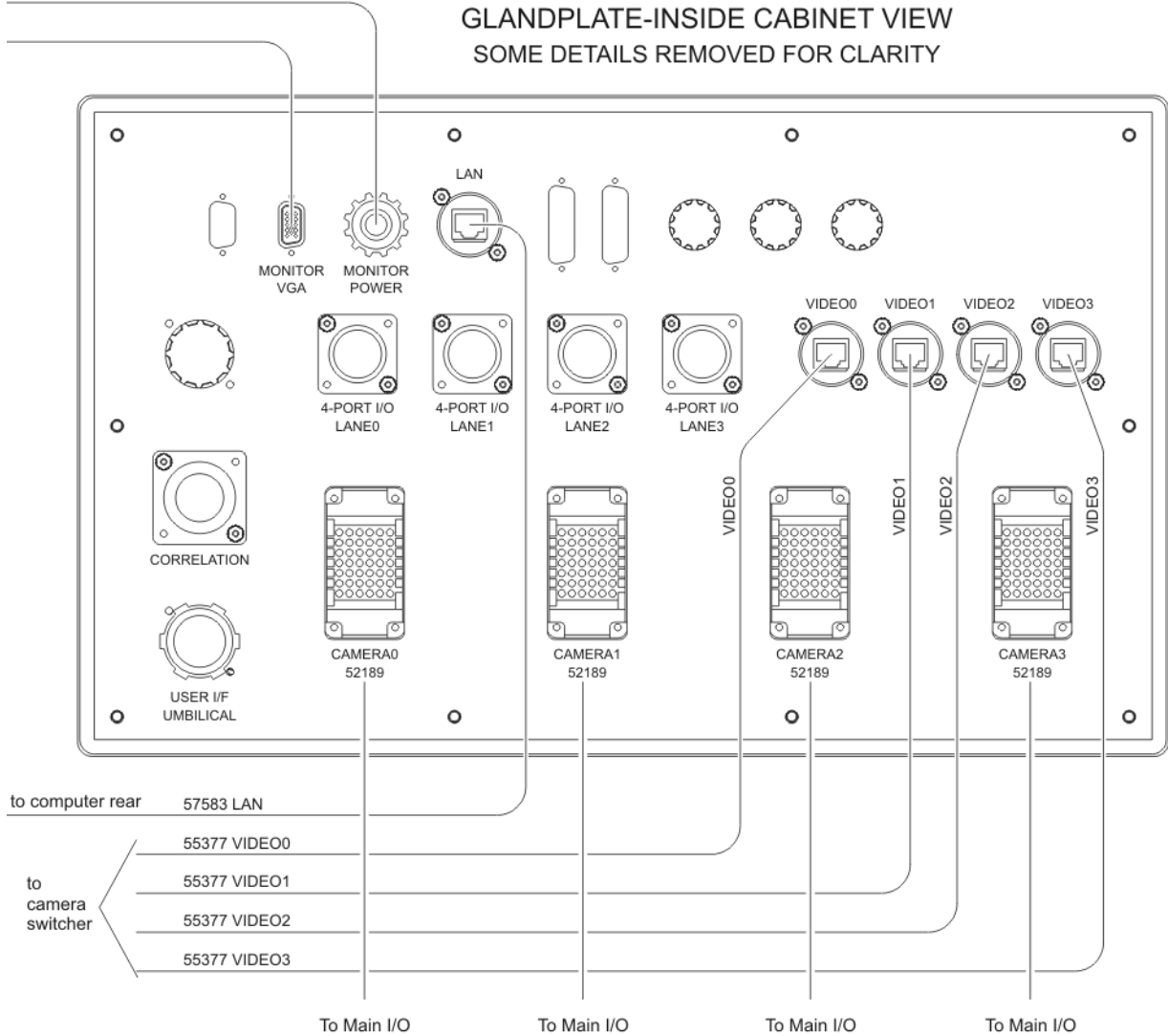

COMPUTER CONNECTIONS S IV-D

MAIN I/O PCB 52830

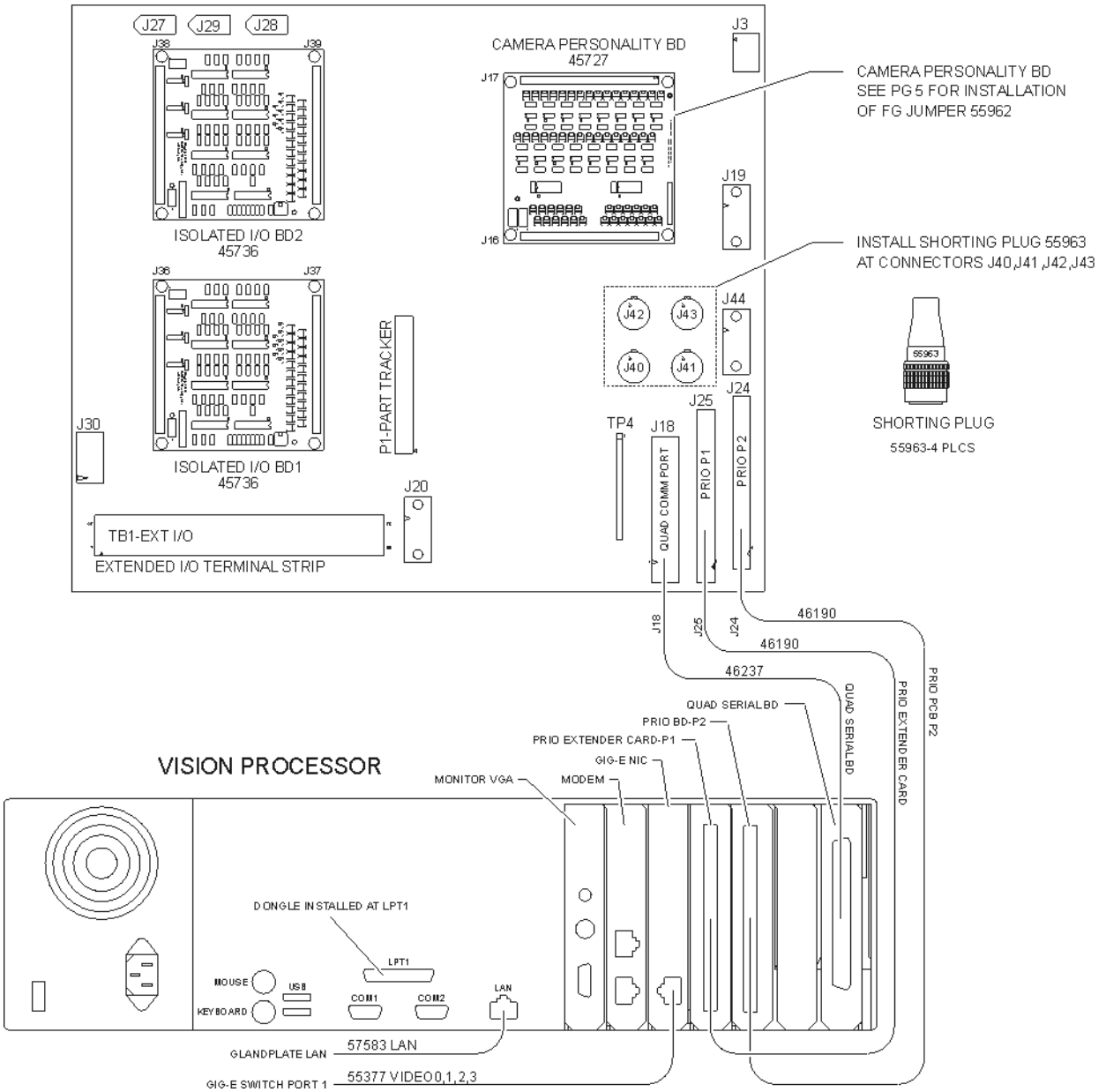

FG TRIGGER JUMPER S IV-D

INSTALLATION OF FG TRIGGER JUMPER 55962 ON CAMERA PERSONALITY PCB

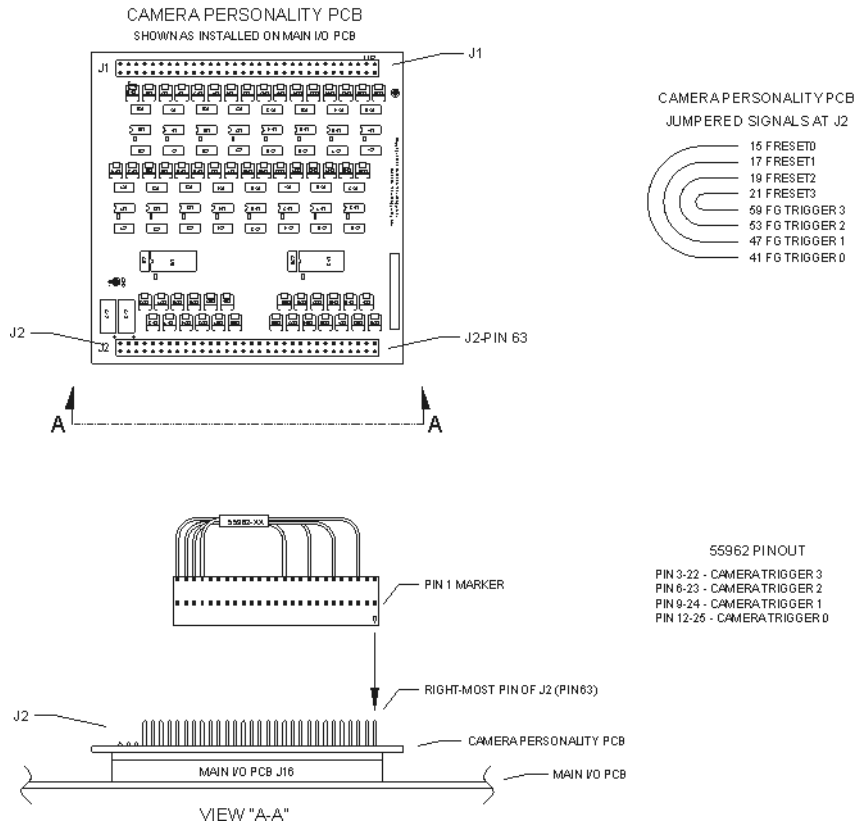

MAIN I/O FRONT CONNECTIONS S IV-D

MAIN I/O PCB 52830

(SOME CABLES MAY NOT BE PRESENT)

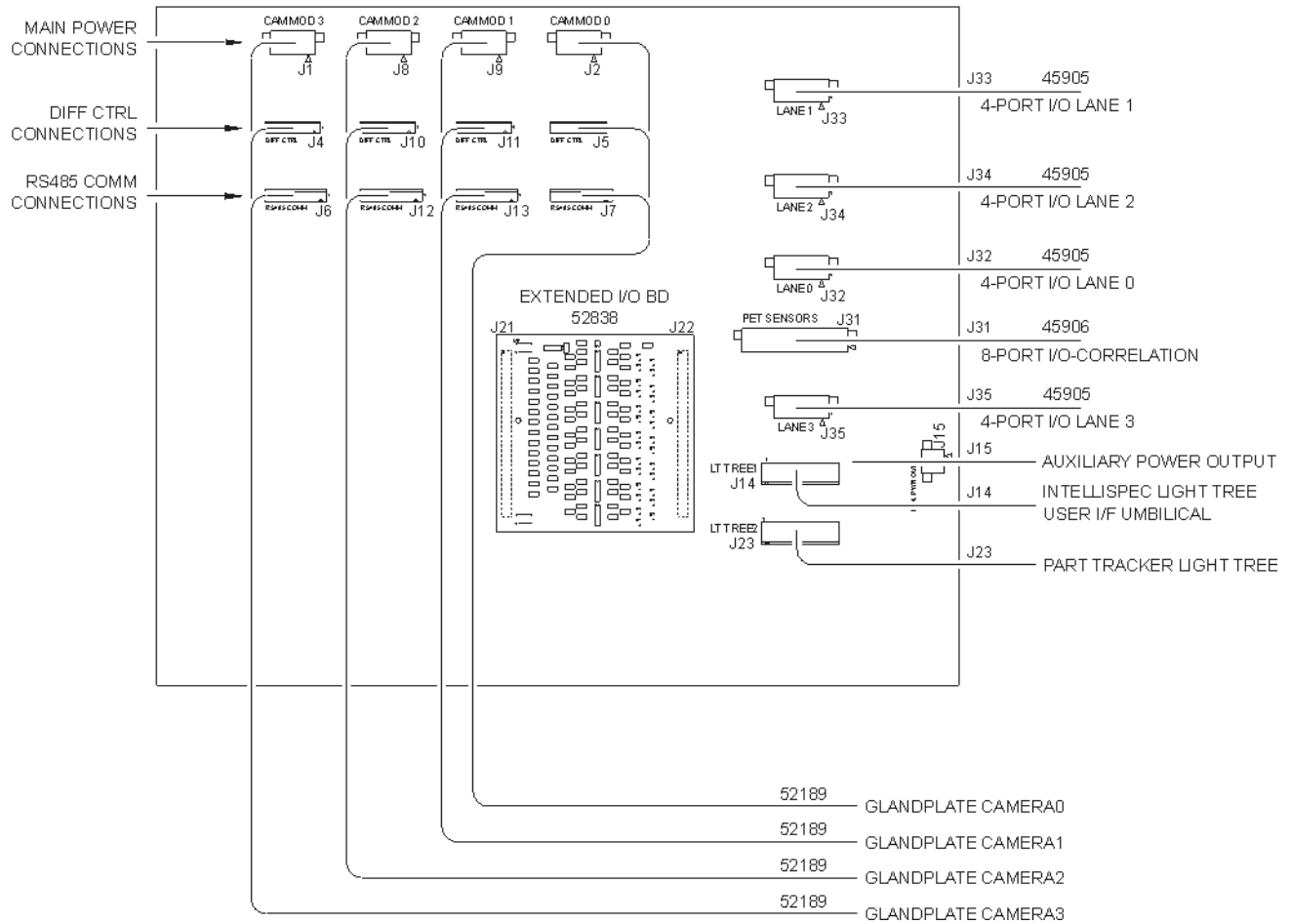

AC/DC POWER DRAWER WIRING DETAILS

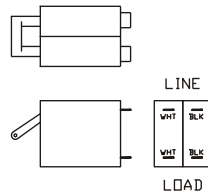
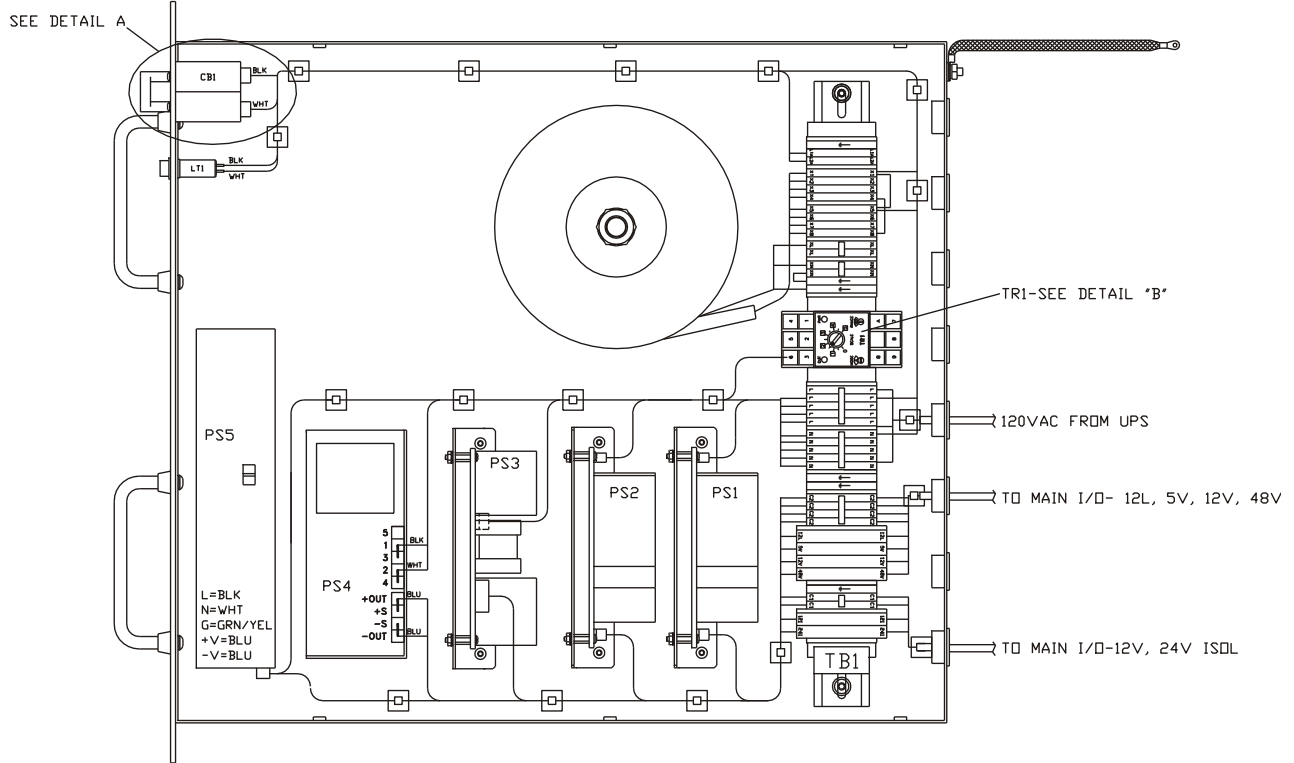

DETAIL "A"
CIRCUIT BREAKER-CBI

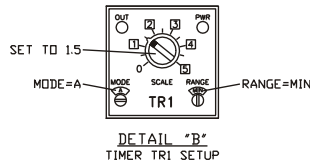

DETAIL "B"
TIMER TR1 SETUP

POWER SUPPLIES
 PS1 - 12V ISOLATED I/O PS
 PS2 - 24V ISOLATED I/O PS
 PS3 - 5V/12V ELECTRONICS PS
 PS4 - 12V CAMERA PS
 PS5 - 48V ARRAY PS

AC/DC Power Drawer Terminal Block

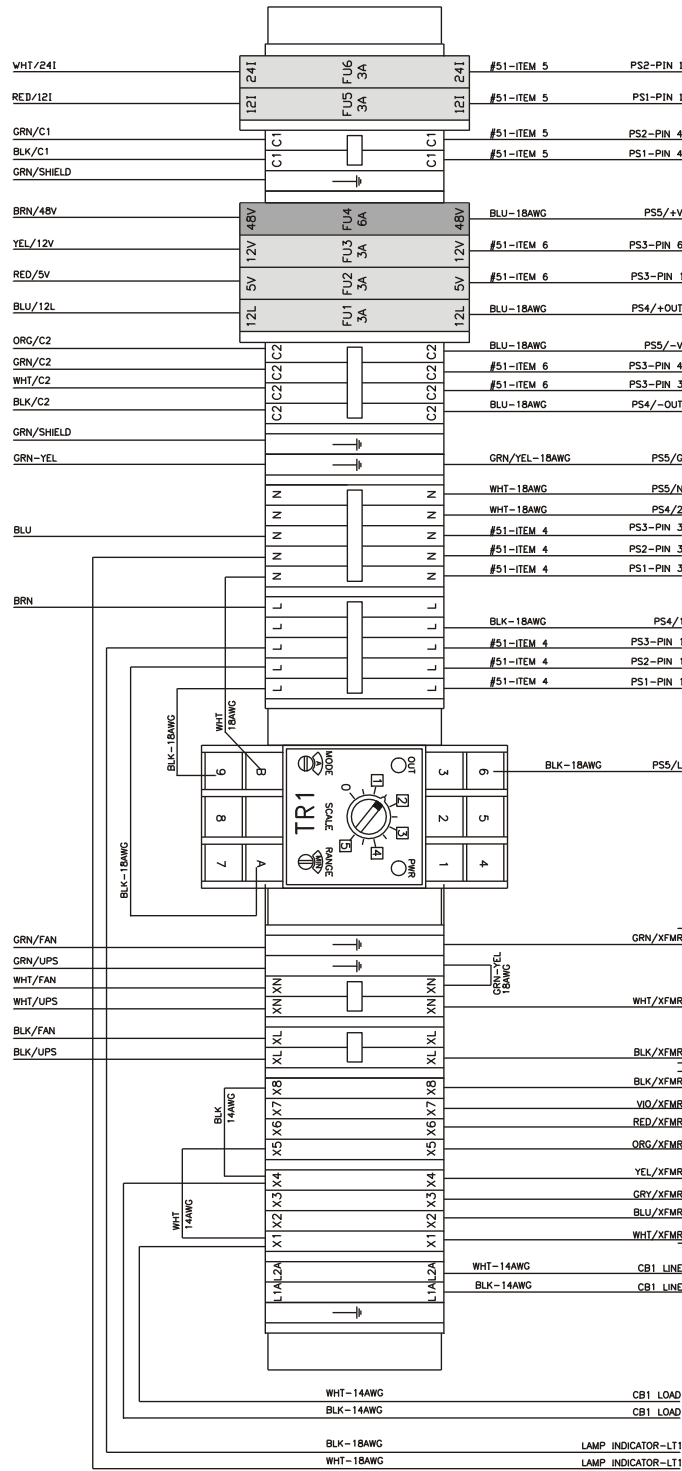

POWER SUPPLIES

- PS1 = 12V Isol. PS
- PS2 = 24V Isol. PS
- PS3 = 5/12V PS
- PS4 = 12V Linear PS
- PS5 = 48V PS

TRANSFORMER WIRING CHART

INPUT VOLTAGE	L1A	L2A	JUMPERS		OUTPUT VOLTAGE
			WHT	BLK	
100VAC	X2	X1	X1-X5	X2-X6	120VAC
110VAC	X3	X1	X1-X5	X3-X7	120VAC
120VAC	X4	X1	X1-X5	X4-X8	120VAC
200VAC	X6	X1	-	X2-X5	120VAC
220VAC	X7	X1	-	X3-X5	120VAC
230VAC	X7	X1	-	X4-X5	120VAC
240VAC	X8	X1	-	X4-X5	120VAC

NOTES:

- SET TIMER, TR1, PER TIMER INSTRUCTIONS FOR 90 SEC ON-DELAY.
- XFMR WIRING SHOWN FOR 120VAC PRI/120VAC SEC.

FUSES

Pressco part number

26943	FU1, FU2, FU3, FU5, FU6 3A 250V 5x20mm glass fast acting
53920	FU4 6.3A 250V 5x20mm time delay

AC POWER SWITCH AND FAN WIRING SERIES IV

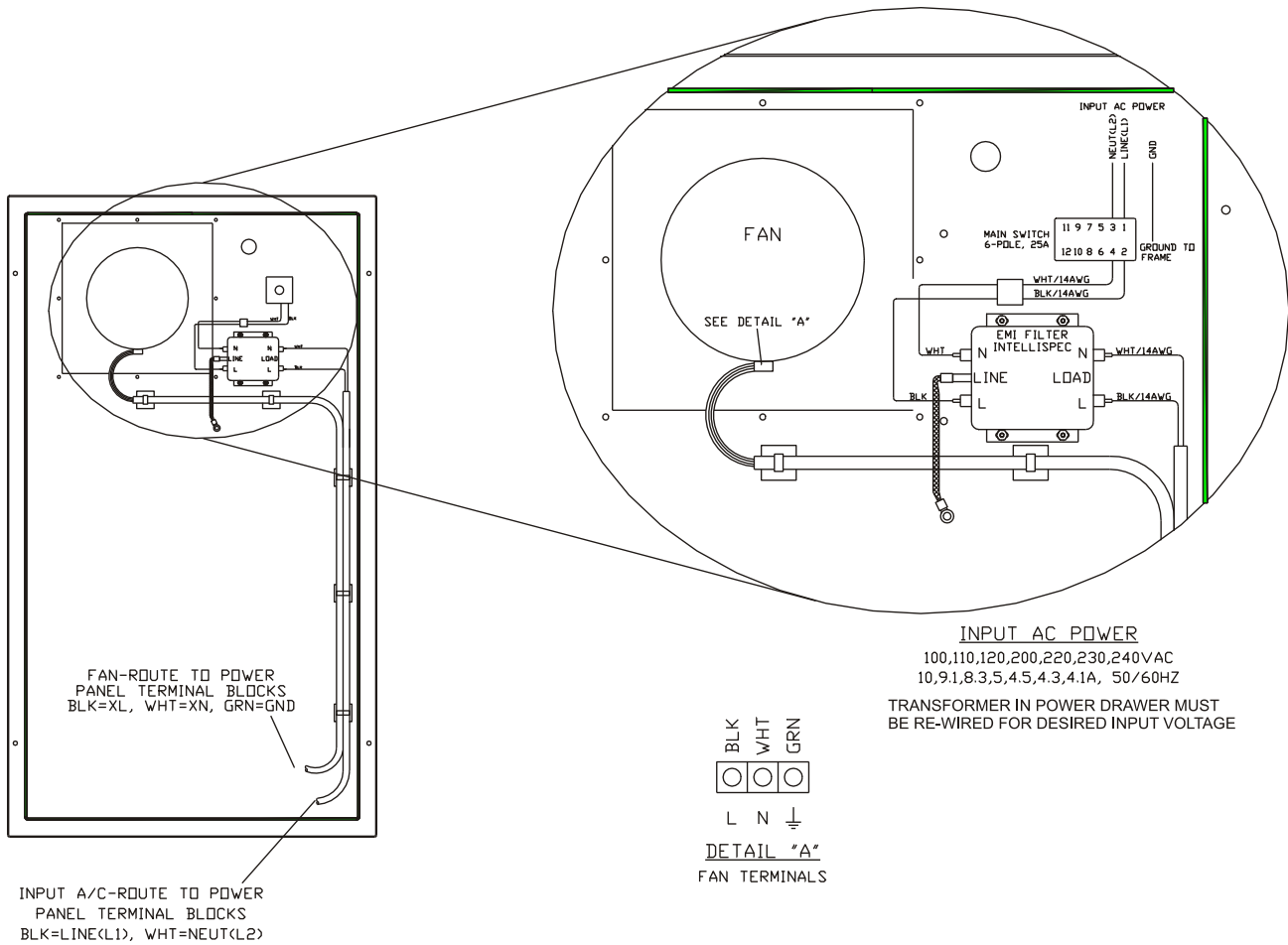

AIR CONDITIONING UNIT MULTI-VOLT WIRING S IV-D

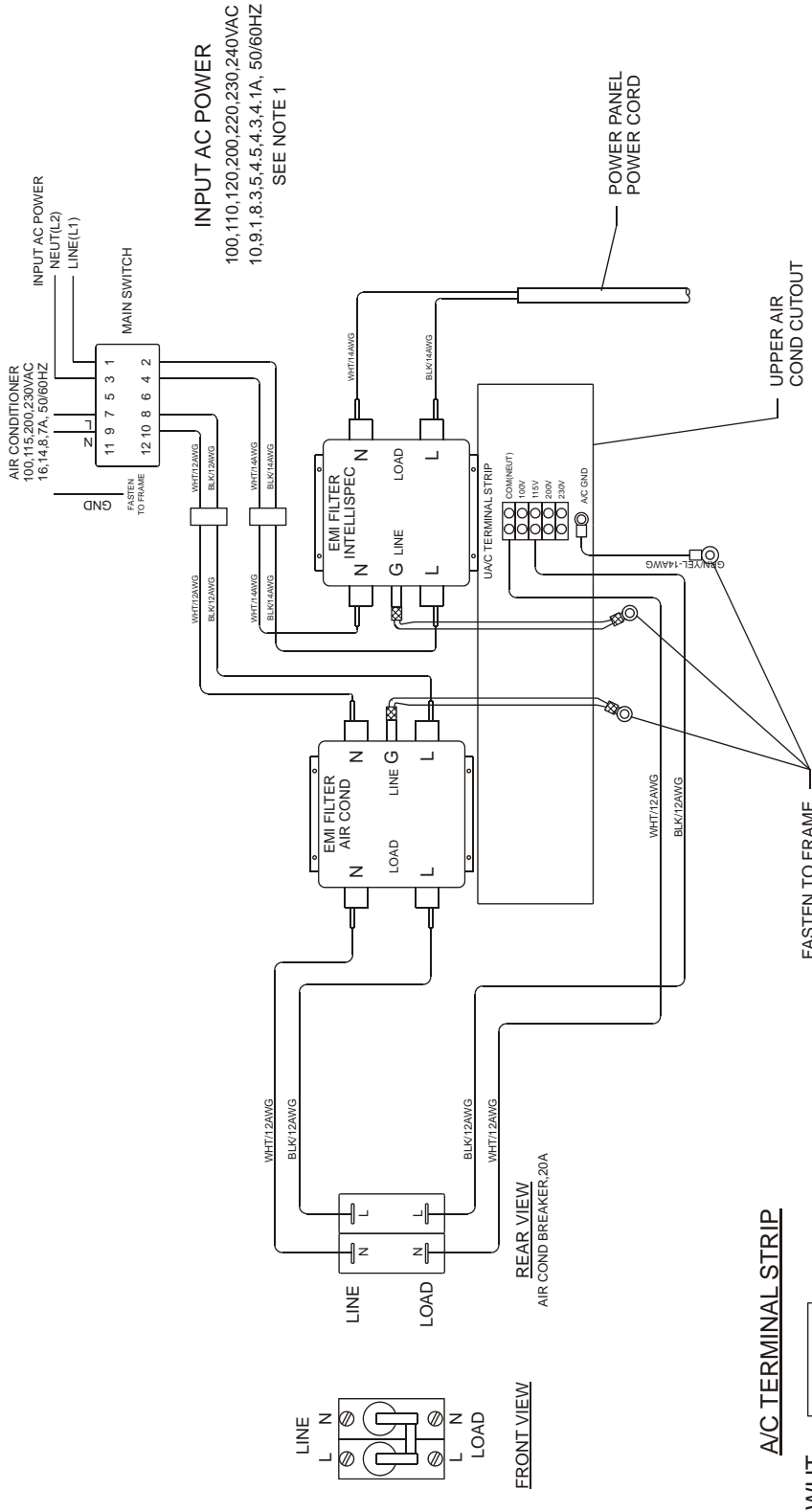

WIRING SHOWN FOR 115VAC INPUT
CONNECT BLACK WIRE TO DESIRED INPUT VOLTAGE ON THE AIR COND TERMINAL STRIP

NOTES:

- 1) TRANSFORMER IN POWER DRAWER MUST BE REWIRED FOR DESIRED INPUT VOLTAGE.

A/C TERMINAL STRIP

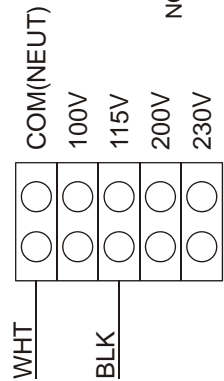

Chapter 7

JUMPER AND SWITCH SETTINGS

This section provides the jumper and switch settings for boards in the Intellispec Processor Cabinet and Inspection Modules. The jumper and switch settings configure the Intellispec System to operate correctly in different production settings. In most cases, the jumper and switch settings are made at Pressco and will not require changes at the installation site.

CIRCUIT BOARD PROTECTION

Observe the following precautions when handling an Intellispec System circuit board.

Turn Off System Power

CAUTION

Make sure the Intellispec System power is off before attempting to remove any circuit board. Removing a circuit board with the system power on may cause serious damage to the equipment.

The Intellispec must be shut down properly, depending how the UPS is set up.

To see whether your system's UPS is configured:

USER LEVEL: ADMINISTRATOR

1. Log in. The system must be offline.
2. Click the  button.
3. Under the System tab, check the Show All Advanced Parameters button. The UPS is configured if the box next to 'UPS Configured' is checked.

If the UPS is configured

(All user levels) If the UPS is configured, simply switch off the rotary switch on the left side of the Processor Cabinet.

If the UPS is not configured

To shut down the Intellispec system, you must be logged in as an Administrator, and system must be Offline.

Warning

Do not shut off the power switch while the Intellispec is still running. The system must go through its proper shutdown sequence. This prevents loss of production data as well as possible program corruption.

To shut down Intellispec:

1. Click the  button.
2. Click Shutdown.
3. Switch off the rotary switch on the left side of the Processor Cabinet.

Static Discharge Protection



Caution

Electronic components can be damaged by static electricity discharge.

Always observe the following precautions before removing, installing or handling any electronic components within the Inspection System:

- Wear an anti-static wristband which is grounded to the Inspection System.
- Stand on an anti-static, grounded floor mat, and lay circuit boards on the mat during any board replacement.
- Keep circuit boards in static shield bags when storing and transporting. Ensure the bag is sealed.

Processor Cabinet Jumper/Switch Settings

4-Port Serial Board Jumper Settings

The 4-port serial board is located inside the vision processor computer.

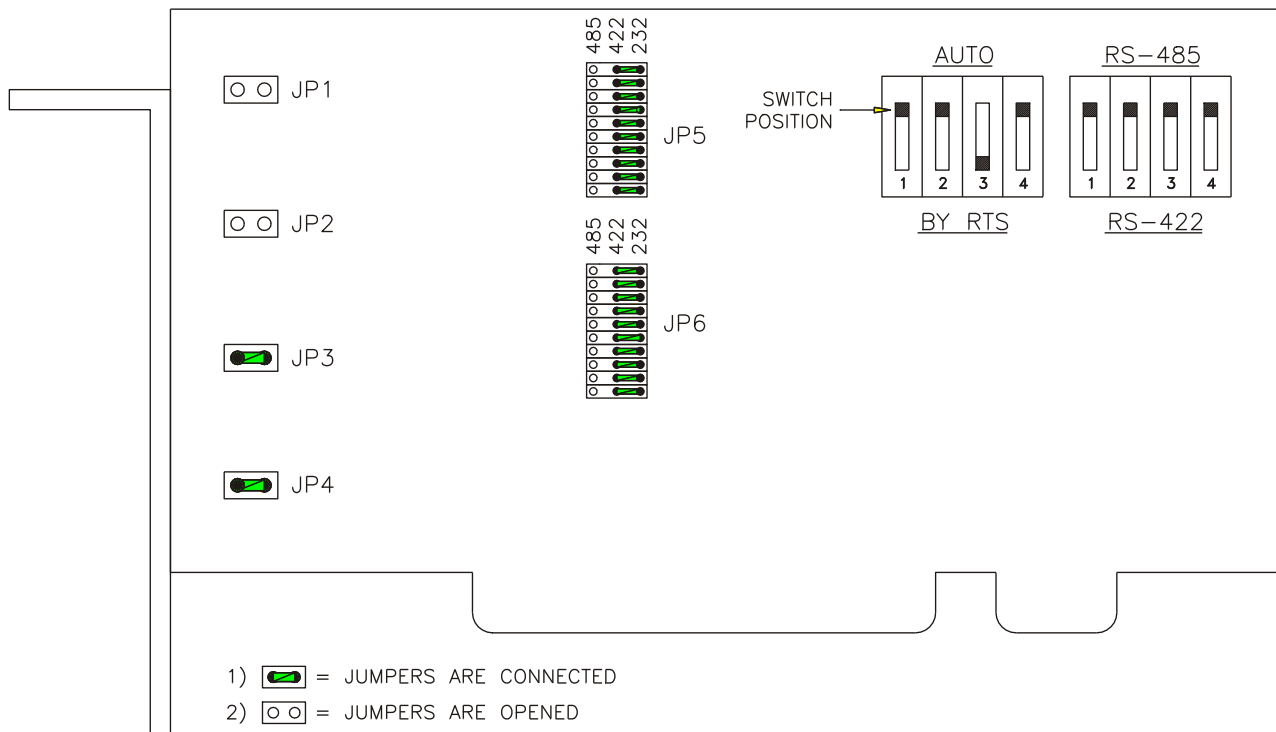

Camera Module Jumper/Switch Settings

This section contains boards for all types of Intellispec modules. Some of these modules will not apply to your system.

Camera signal distribution board S IV-D+

Camera signal distribution board [58256] is new for Series IV-D+ systems. There are no jumpers or switches to set for this board.

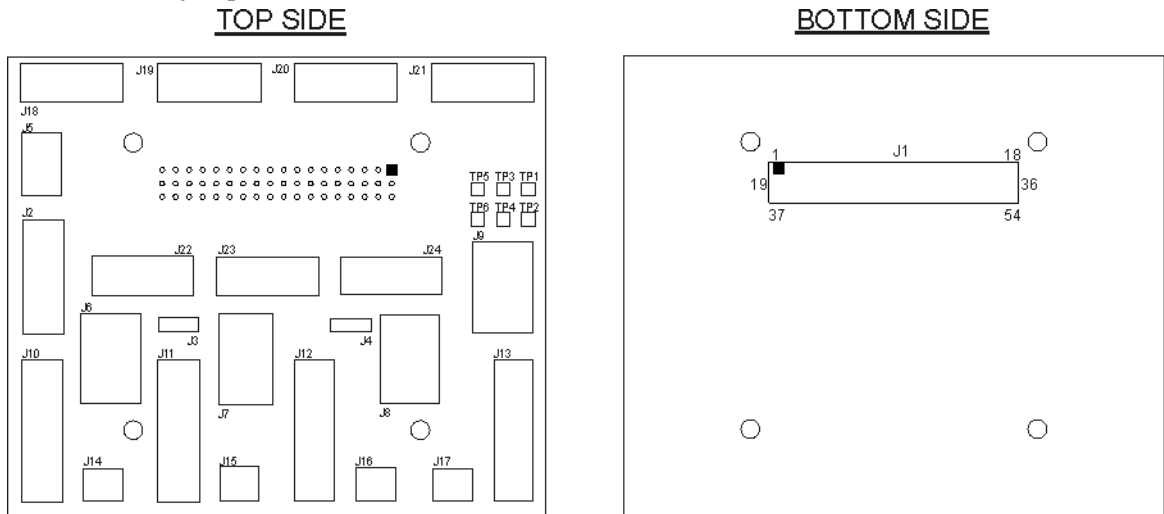

Base and Neck Lighting Board Switch Settings

The Base and Neck Lighting boards are located in their respective lighting modules. If replacing a Base or Neck Lighting Board, refer to the following tables and illustration for the setting and location of jumpers and switches. The default setting for the device address switch will differ if more than one of a board type is installed.

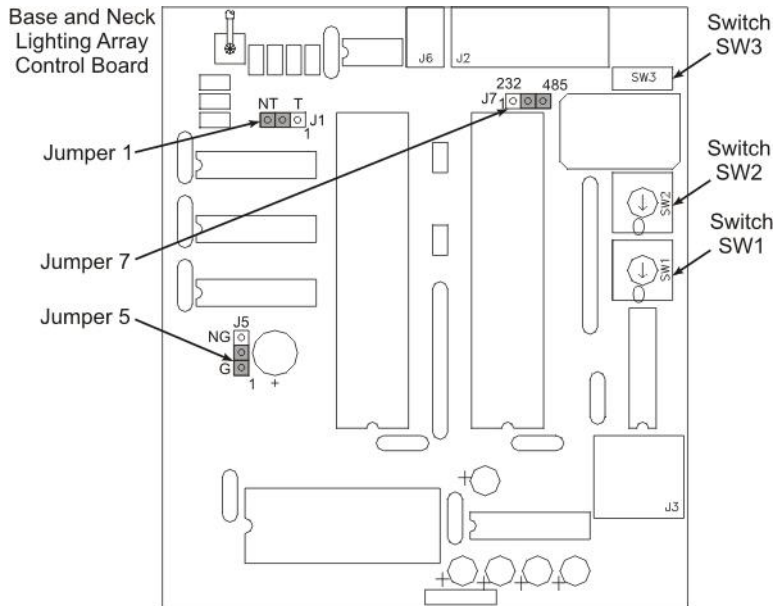

Jumper No.	Jumper Setting / Function	Default Setting
1	1-2, 120 Ohm Termination 2-3, no termination	2-3 (NT)

5	1-2, Short 48-Volt return signal to 5-Volt and 12-Volt return. 2-3, Isolate 48-Volt return signal.	1-2 (G)
7	1-2, RS-232 communication port enabled. 2-3, RS-485 communication port enabled.	2-3 (485)

Switch No.	Switch Function	Default Setting
SW1	Device address	Base - 1, Neck - 2
SW2	Trigger dwell - manual control. (Switch 2 setting is ignored if EEPROM U4 is installed.)	7
SW3	Light reset - resets to default lighting parameters.	N/A

Seal Surface Lighting Board Switch Settings

The Seal Surface Lighting boards are located in their respective lighting modules. If replacing a Seal Surface Lighting Board, refer to the following tables and illustration for the setting and location of jumpers and switches. The device address default setting will differ if more than one seal surface lighting board is installed.

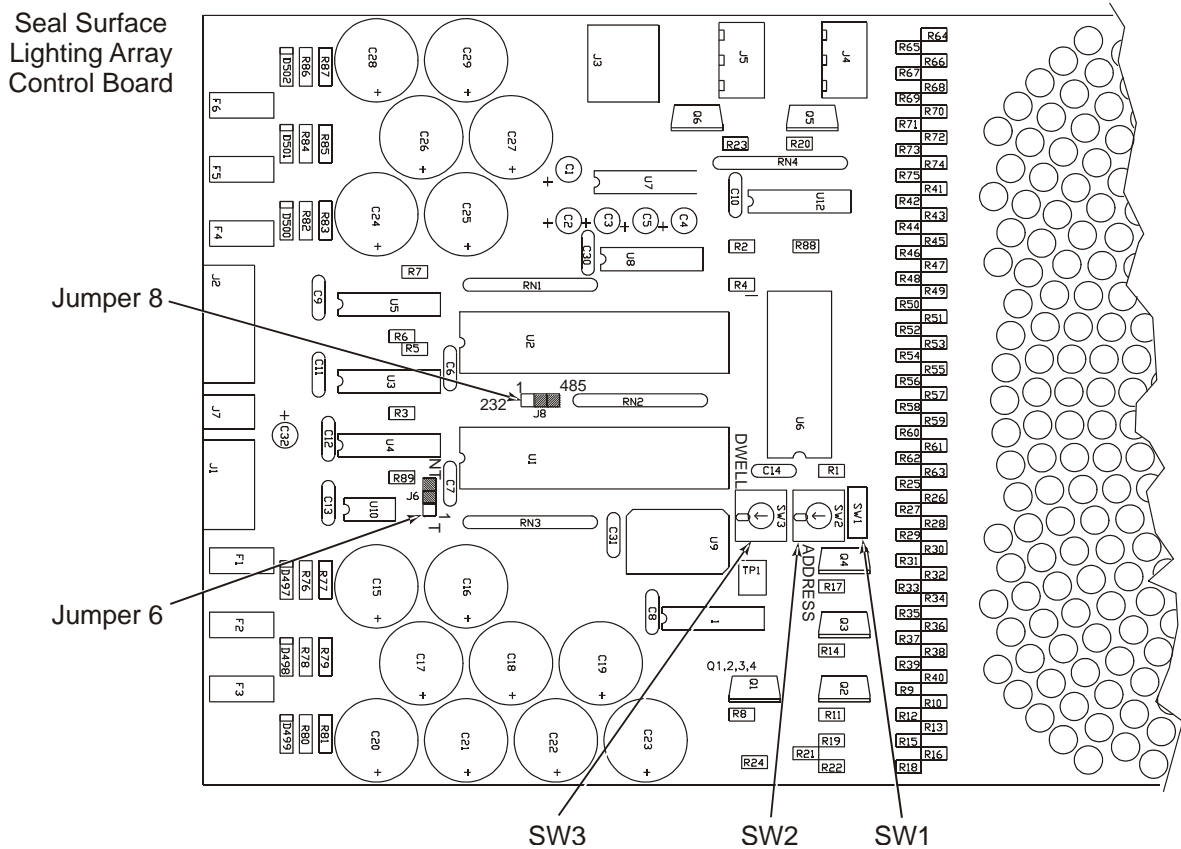

Jumper	Jumper Setting/ Function	Default Setting
6	1-2, 120 Ohm termination 2-3, no termination	2-3 (NT)
8	1-2, RS-232 communication port enabled. 2-3, RS-485 communication port enabled.	2-3 (485)

Switch	Switch Function	Default Setting
SW1	Light reset - resets to default lighting parameters.	N/A
SW2	Device address	3
SW3	Trigger dwell - manual control. (Switch 2 setting is ignored if EEPROM U6 is installed.)	7

Base and Neck Camera Signal Distribution Board Jumper Settings

Signal Distribution Board - (43540)

Used inside camera modules

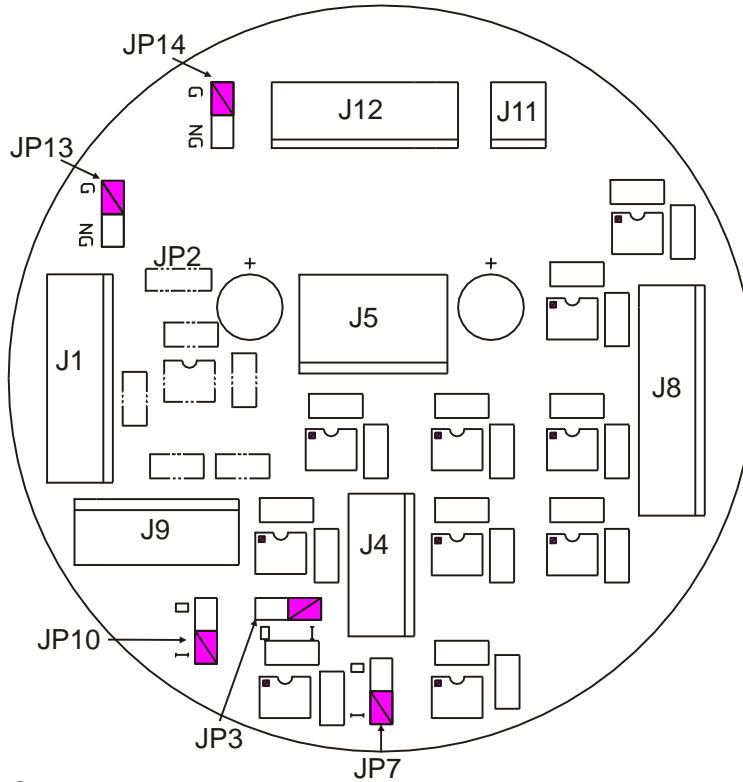

Connectors

- J1 - Camera control to camera (cable 43913)
- J4 - Configurable I/O (not used in most applications)
- J5 - LED power (cable 43912)
- J8 - LED control to lighting array (cable 44873)
- J9 - Output power (not used in most applications)
- J11 - RS485 _1_out signals (cable 43912)
- J12 - Focus control (cable 43915)

Jumper	Jumper Setting/ Function	Default Setting
2	Not installed	--
3, Configurable I/O 1	1-2, I/O 1 is a receiver 2-3, I/O 1 is a driver	1-2 (I)
7, Configurable I/O 2	1-2, I/O 2 is a receiver 2-3, I/O 2 is a driver	1-2 (I)
10, Configurable I/O 3	1-2, I/O 3 is a receiver 2-3, I/O 3 is a driver	1-2 (I)
13	1-2, 48V return shorted to 5V & 12V return 2-3, 48V return isolated	1-2 (G)

14	1-2, Camera return shorted to 5V & 12V return 2-3, Camera return isolated	1-2 (G)
----	--	---------

Camera Driver Board Jumper Settings

Camera Driver Board (43120)

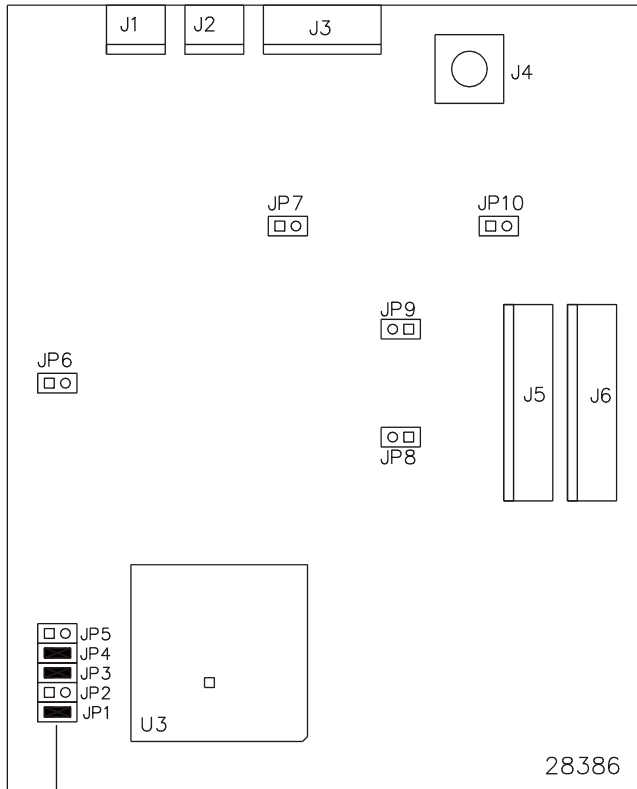

ADDRESS SHOWN=SOSSO

Used in Base/ Neck/ Preform sidewall/ Endcap camera boxes (not Seal Surface)

Jumper Definitions

HEX ADDRESS	JP1	JP2	JP3	JP4	JP5
00	S	S	S	S	S
01	S	S	S	S	0
02	S	S	S	0	S
03	S	S	S	0	0
--	-	-	-	-	-
1C	0	0	0	S	S
1D	0	0	0	S	0
1E	0	0	0	0	S
1F	0	0	0	0	0

S - SHUNT=LOGIC '0'
 0 - OPEN=LOGIC '1'

JUMPER	FUNCTION	NOTES
JP6	RS485 COMMUNICATIONS TERMINATION	USE SHUNT TO TERMINATE WHEN THE CAMERA MODULE IS THE LAST ONE ON THE LINE
JP7	OUTPUT VSYNC CAMERA DRIVER IMPEDANCE	OPEN - 160 OHM OUTPUT SHUNT - 75 OHM OUTPUT
JP8	VERTICAL SYNC. DIFF. RECEIVER TERMINATION	USE SHUNT TO TERMINATE WHEN THE CAMERA MODULE IS THE LAST ONE ON THE LINE
JP9	HORIZONTAL SYNC. DIFF. RECEIVER TERMINATION	USE SHUNT TO TERMINATE WHEN THE CAMERA MODULE IS THE LAST ONE ON THE LINE
JP10	OUTPUT HYSNC CAMERA DRIVER IMPEDANCE	OPEN - 160 OHM OUTPUT SHUNT - 75 OHM OUTPUT

Jumper Settings

Ispec 1	JP1	JP2	JP3	JP4	JP5	JP6	JP7	JP8	JP9	JP10
BASE	S	0	S	0	S	S	0	S	S	0
NECK	S	0	S	0	0	S	0	S	S	0
N/A	S	0	0	S	S	S	S	S	S	S

S - SHUNT; 0=OPEN

Ispec 2,3	JP1	JP2	JP3	JP4	JP5	JP6	JP7	JP8	JP9	JP10
CH 1	S	0	S	0	S	0	0	0	0	0
CH 2	S	0	S	0	0	0	0	0	0	0
CH 3	S	0	0	S	S	0	0	0	0	0
CH 4	S	0	0	S	0	0	0	0	0	0

S - SHUNT; 0=OPEN

Connections: ISPEC 1, 2, & 3

J1-Output to FOCUS servo.

J2-N/C.

J3-N/C.

J4-N/C.

J5/J6-Input power/sync/comm.

Interchangeable.

Chromapulse Signal Distribution Board 1 Jumper Settings

Chromapulse Signal Distribution Board 44212 (one camera connector)

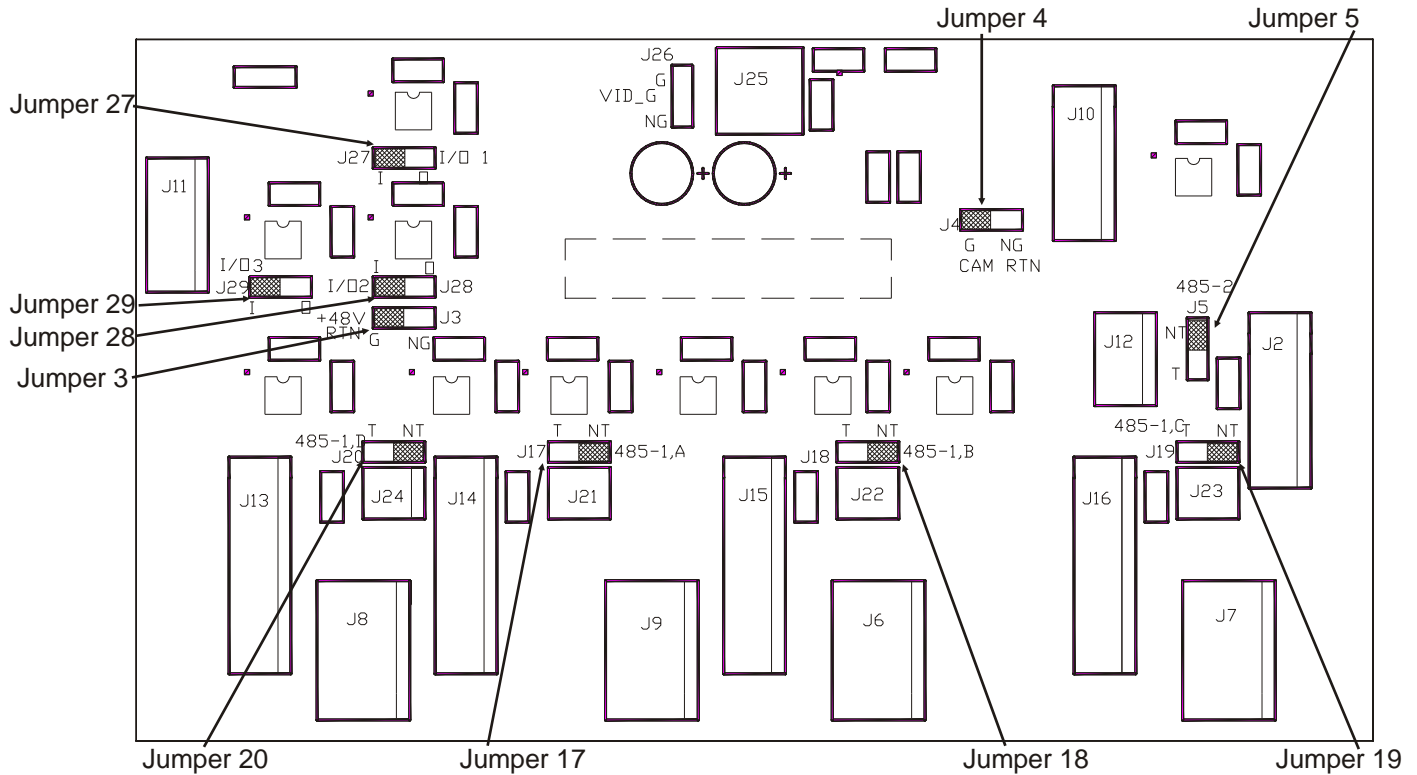

Jumper	Jumper Setting/ Function	Default Setting
3	1-2, 48V return shorted to 5V and 12V return 2-3, 48V return isolated	1-2 (G)
4	1-2, Camera return shorted to 5V and 12V return 2-3, Camera return isolated	1-2 (G)
5	1-2, 120 Ohm termination – focus control 2-3, No termination resistor	2-3 (NT)
17	1-2, 120 Ohm termination – light control, Ctlr1 2-3, No termination resistor	2-3 (NT)
18	1-2, 120 Ohm termination – light control, Ctlr2 2-3, No termination resistor	2-3 (NT)
19	1-2, 120 Ohm termination – light control, Ctlr3 2-3, No termination resistor	2-3 (NT)
20	1-2, 120 Ohm termination – light control, Ctlr4 2-3, No termination resistor	2-3 (NT)
27 - Config I/O1	1-2, I/O1 is a receiver 2-3, I/O1 is a driver	1-2 (I)
28 - Config I/O2	1-2, I/O2 is a receiver 2-3, I/O2 is a driver	1-2 (I)

29 - Config I/O3	1-2, I/O3 is a receiver 2-3, I/O3 is a driver	1-2 (I)
------------------	--	---------

Chromapulse Signal Distribution Board 2 Jumper Settings

46725

Chromapulse Signal Distribution Board 46725 (two camera connectors)

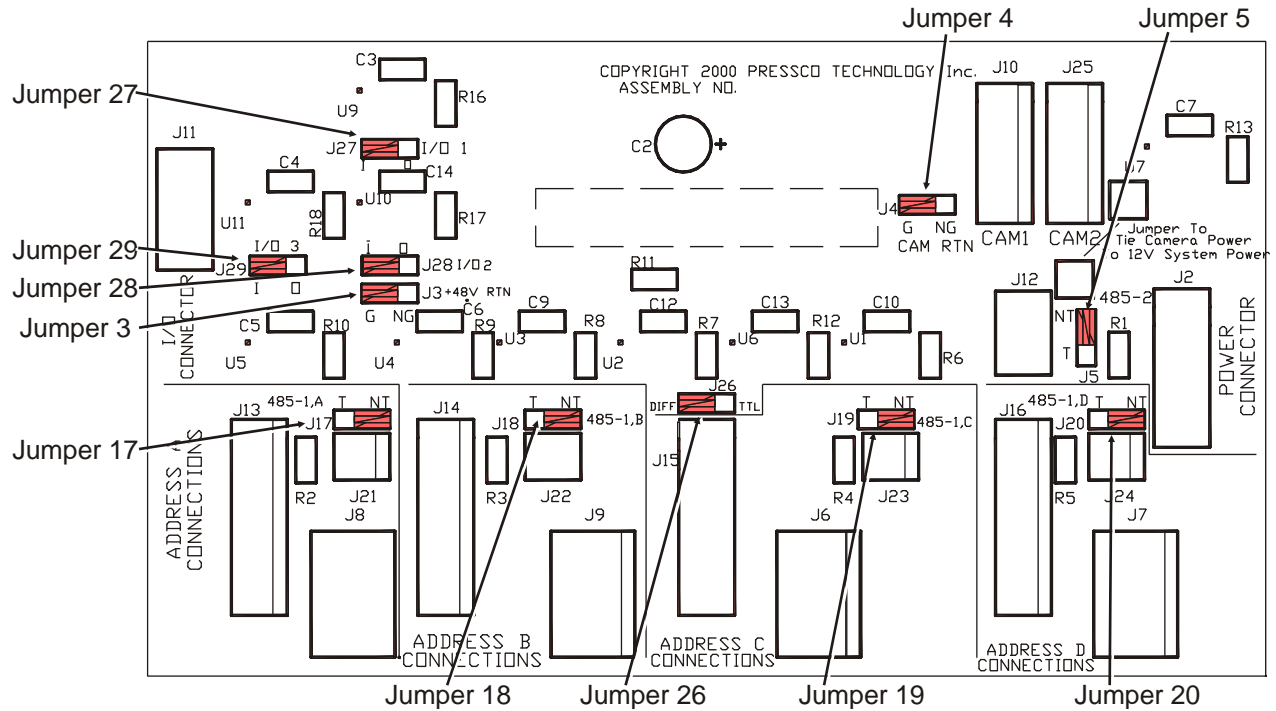

Jumper	Jumper Setting/ Function	Default Setting
3	1-2, 48V return shorted to 5V and 12V return 2-3, 48V return isolated	1-2 (G)
4	1-2, Camera return shorted to 5V and 12V return 2-3, Camera return isolated	1-2 (G)
5	1-2, 120 Ohm termination – focus control 2-3, No termination resistor	2-3 (NT)
17	1-2, 120 Ohm termination – light control, Ctlr1 2-3, No termination resistor	2-3 (NT)
18	1-2, 120 Ohm termination – light control, Ctlr2 2-3, No termination resistor	2-3 (NT)
19	1-2, 120 Ohm termination – light control, Ctlr3 2-3, No termination resistor	2-3 (NT)
20	1-2, 120 Ohm termination – light control, Ctlr4 2-3, No termination resistor	2-3 (NT)
26	1-2, used for Intellispec applications 2-3, used for Interrogator applications	1-2 (DIFF)

27 - Config I/O1	1-2, I/O1 is a receiver 2-3, I/O1 is a driver	1-2 (I)
28 - Config I/O2	1-2, I/O2 is a receiver 2-3, I/O2 is a driver	1-2 (I)
29 - Config I/O3	1-2, I/O3 is a receiver 2-3, I/O3 is a driver	1-2 (I)

Chromapulse Lighting Board Switch Settings

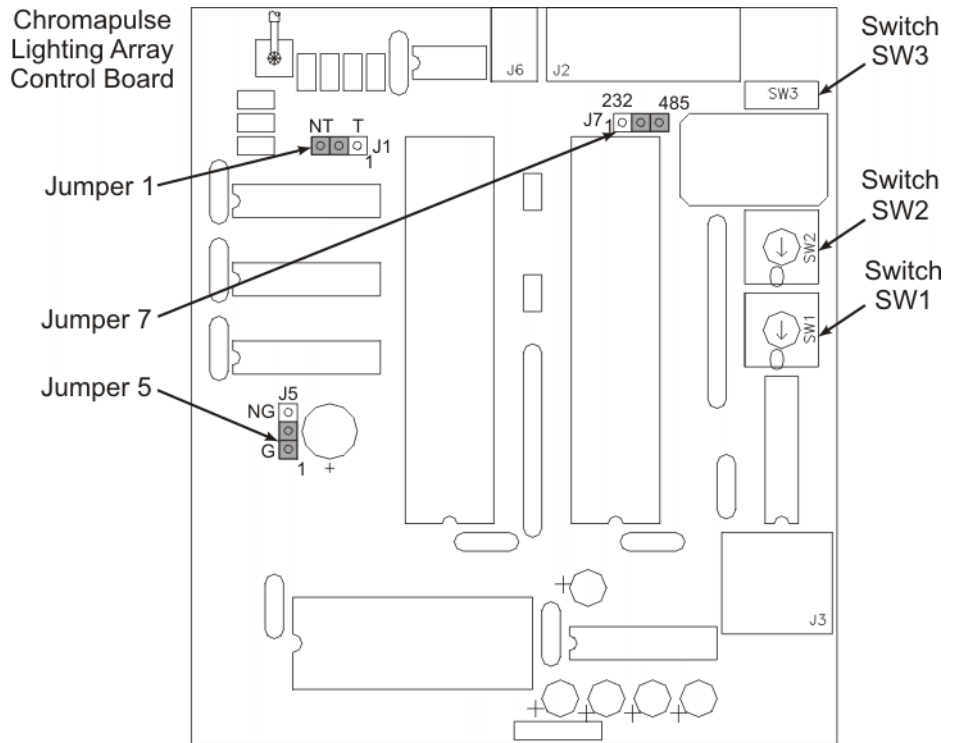
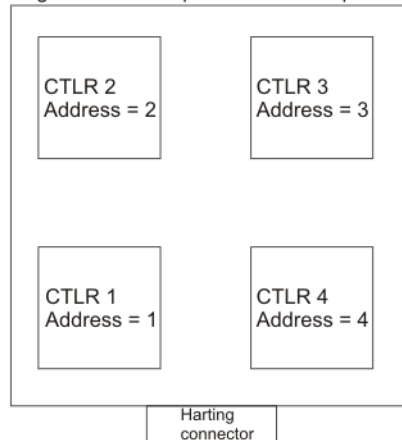

Figure 1: Chromapulse Tunnel - Top View



Jumper	Jumper Setting/ Function	Default Setting
1	1-2, 120 Ohm termination 2-3, no termination	2-3 (NT)
5	1-2, Short 48-Volt return signal to 5-Volt and 12-Volt return. 2-3, Isolate 48-Volt return signal.	1-2 (G)
7	1-2, RS-232 communication port enabled. 2-3, RS-485 communication port enabled.	2-3 (485)

Switch	Switch Function	Default Setting
SW1	Device address	See Figure 1
SW2	Trigger dwell - manual control. (Switch 2 setting is ignored if EEPROM U4 is installed.)	7
SW3	Light reset - resets to default lighting parameters.	N/A

Video Multiplexer Board Jumper Settings Video Multiplexer Board (53884)

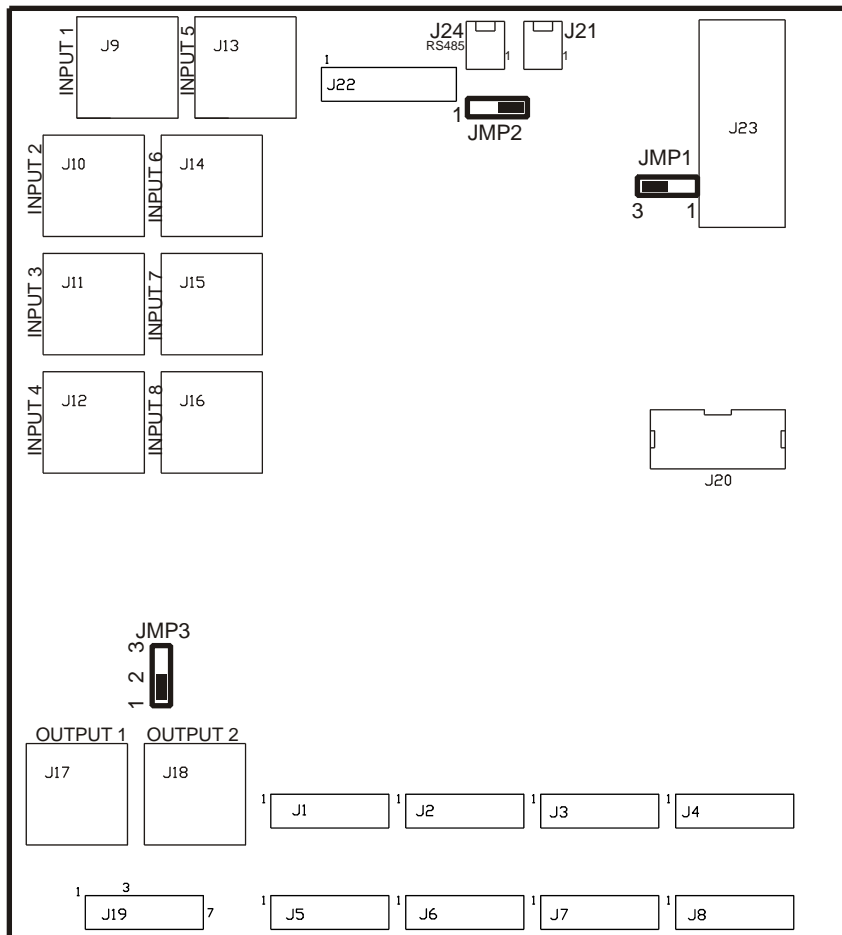

Jumper	Jumper Setting/ Function	Default Setting
1	1-2, RS-232 communication port enabled. 2-3, RS-485 communication port enabled.	2-3
2	1-2, 120 Ohm termination 2-3, no termination	2-3
3	1-2, Normal setting 2-3, Subtracts video output 1 from video output 2	1-2

Chapter 8

MAINTENANCE FREQUENCY

An optics cleaning kit is available from Pressco. **Contact** (see "How to Contact Pressco" on page 272) the Spare Parts department.

Intellispec Processor Cabinet and General Components			
Item	Description	Once per day or shift	Once per month
Observe Proper inspection	Verify that defective parts are being rejected by inserting a known defective part through inspection	X	
Observe Proper inspection	Verify that no stray parts are stuck in or near the inspection module or reject station	X	
Observe Proper inspection	Verify that no buildup of dirt or contaminants has occurred on inspection module, part detector, or conveyor. Clean if necessary.	X	
Observe Proper inspection	Verify that each channel's image is properly centered, focused, and properly lit. Adjust if necessary.	X	
Processor Cabinet air circulation filters	Rinse (see "Cleaning the Processor Cabinet Air Filters" on page 98) in clean water; use mild soap and water solution if oily.		X
PC air filter	Rinse (see "Cleaning the PC Air Filter" on page 98) in clean water; use mild soap and water solution if oily.		X
Air conditioner filter	Rinse (see "Cleaning the Air Conditioner Filter" on page 99) in clean water; use mild soap and water solution if oily.		X

Inspection Modules Chromapulse			
Item	Description	Once per day or shift	Once per month
Part Detect Sensor and Reflector	Clean (see "Cleaning the Part Detector" on page 95) with soft, clean, oil-free cloth dampened with mild soap and water solution. Wipe dry.	Once per week	
Camera lens	Clean (see "Cleaning the Camera Lens" on page 89) only with lens tissue and lens cleaner. Be careful not to alter focus or aperture.		X
Glass surfaces: Beam Splitter and Secondary lens	Clean (see "Cleaning Glass Surfaces" on page 88) with soft, clean, oil-free cloth dampened with lens cleaning solution.		X
Ellipsoidal mirror	Normally does not need cleaning. If dirty, blow off		Only if dirt

on CP4402, CP4402E, CP4411,CP4412	dust with compressed air, and follow instructions (see "Cleaning the Ellipsoidal Mirror" on page 94).		appears on image
Plastic surfaces: Dome light or Ring light diffusers	Clean (see "Cleaning Plastic Surfaces" on page 92) with soft, clean, oil-free cloth dampened with mild soap and water solution. Wipe dry.		X
CP4411E, CP4412E	Oil shafts of mounting assembly (see "Maintaining the Mounting Assembly" on page 96) to prevent rusting.		X
CP4411E, CP4412E, CP4422E	<ul style="list-style-type: none"> ▪ Replace (see "Replacing Filter/ Regulator Filters" on page 97) oil removal filter when indicator turns from green to red ▪ Replace oil vapor removal filter 		<ul style="list-style-type: none"> ▪ Every 2000 hours ▪ Every 12 months

CLEANING OPTICAL SURFACES

IMPORTANT

Debris and contamination could build up on both the glass and plastic surfaces. This dirt could appear in the inspection windows, causing false rejects of parts, or it could degrade lighting. Clean glass and plastic surfaces often to avoid false rejects.

To maintain proper image quality and system performance, the clear glass and plastic surfaces on the Inspection Modules must be cleaned on a regular basis. Dirt and debris that appear in the image can cause false rejects. An oily film on optical surfaces can cause false rejects or missed defects.

CLEANING GLASS SURFACES

Glass surfaces that may require cleaning are:

- Camera Lens
- Beam Splitter (if present)
- Secondary lens (if present)
- Secondary mirror (if present)

To clean glass surfaces:

- Blow off dust with canned, compressed air
- Use a clean non-abrasive cloth dampened with lens cleaning solution
- Use lens tissue and lens cleaning solution on camera lenses
- If surface has compound on it, first clean with alcohol, then with lens cleaning solution

❖ *Note: Cleaning frequency will depend on plant and process conditions.*

Cleaning the Camera Lens

Caution

Do not touch the lens with fingers or oily cloths.

To clean the camera lens:

1. Raise the camera to access the lens by loosening the height adjustment screw. The clamping bracket should remain in place.
2. Clean all camera lenses with lens tissue and lens cleaning fluid. Be careful not to alter the focus or aperture of the cameras.
3. Slide the camera back into position as marked by the clamping bracket.
4. Tighten the height adjustment screw
5. Re-adjust aperture and focus if needed.

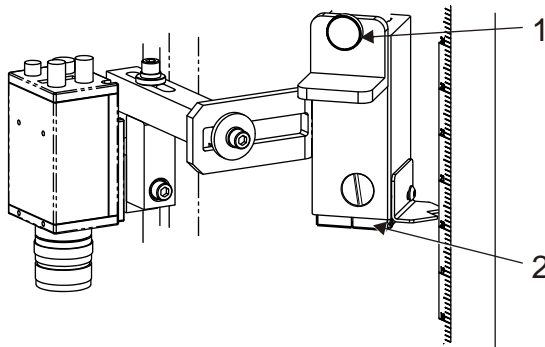

1	Camera height adjustment screw
2	Clamping bracket - camera height reference

Cleaning the Beam Splitter

You must remove the Beam Splitter (on some Chromapulse models) to access the bottom side for cleaning. It is held in place with four thumb screws.

To clean beam splitter:

1. **Raise the camera** (see "Cleaning the Camera Lens" on page 89) if necessary. Be sure to note the camera position before moving it.
2. Loosen the four thumb screws and carefully remove the beam splitter.
3. Clean the beam splitter.
 - Blow off dust from beam splitter with canned, compressed air.
 - **Clean the glass** (see "Cleaning Glass Surfaces" on page 88) on the beam splitter.

- Replace the beam splitter assembly.

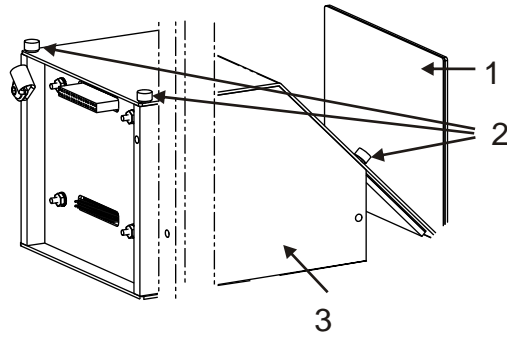

1	Beam splitter assembly
2	Thumb screws (four total)
3	Fill Light or Beam Splitter Diffuser inside

CP/E Series Models

To clean the beam splitter:

- Loosen the screws.
- Remove the mirror from the keyholes.
- Clean the *mirror* (see "Cleaning Glass Surfaces" on page 88).

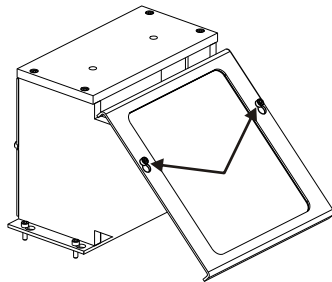

Chromapulse Beam Splitter

You must remove the Beam Splitter (on some Chromapulse models) to access the bottom side for cleaning. It is held in place with four thumb screws.

To clean beam splitter:

- Raise the camera** (see "Cleaning the Camera Lens" on page 89) if necessary. Be sure to note the camera position before moving it.
- Loosen the four thumb screws and carefully remove the beam splitter.
- Clean the beam splitter.
 - Blow off dust from beam splitter with canned, compressed air.
 - **Clean the glass** (see "Cleaning Glass Surfaces" on page 88) on the beam splitter.

- Replace the beam splitter assembly.

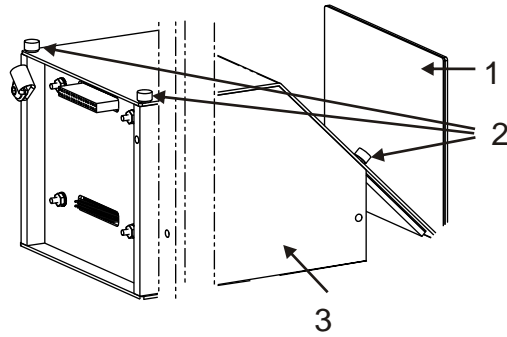

1	Beam splitter assembly
2	Thumb screws (four total)
3	Fill Light or Beam Splitter Diffuser inside

Cleaning the Secondary Lens

If your system is equipped with a Secondary Lens, it needs to be cleaned periodically to ensure optimum inspection. This lens is usually mounted within or near the Ring Light.

The top surface of the Secondary Lens can be accessed for cleaning from inside the Inspection Module. The bottom surface faces the conveyor surface and is usually mounted very close to the conveyor such that there is not enough clearance to reach under the Inspection Module for cleaning. If this is the case, you will have to remove the Secondary Lens to clean the bottom surface.

CP1500 Modules

We recommend that you remove and clean the Secondary Lens (if present) as well as the Ring Light diffuser at the same time.

To clean these components:

- Remove the four cover plates located at the bottom sides of the Inspection Module.
- Locate the brackets with slotted holes (item 2) and remove the screws securing the Secondary lens and ring light frame to the brackets. (Note the position of the screws relative to the slotted holes before removing.)
- Carefully remove the Secondary Lens and its frame, as well as the Ring Light by sliding it out one side of the Inspection Module.
- Clean the the **Secondary Lens** (see "Cleaning Glass Surfaces" on page 88).
- Clean the **Ring Light Diffuser** (see "Cleaning Plastic Surfaces" on page 92).
- Replace these components.

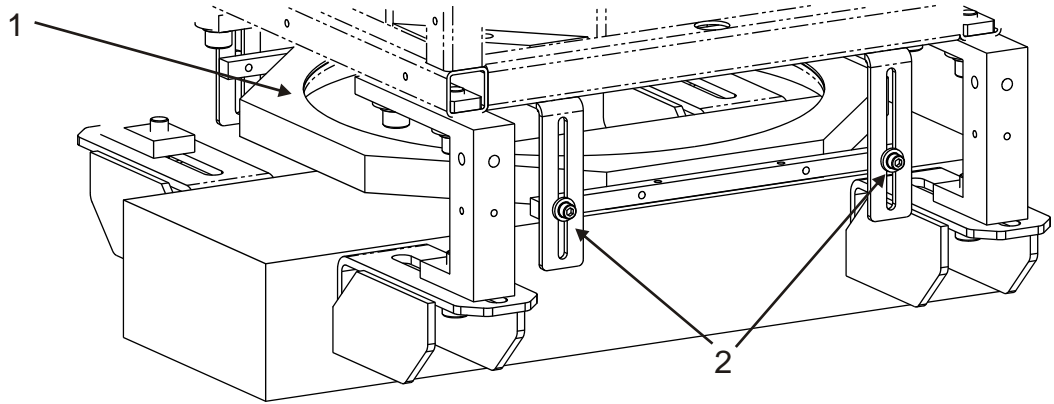

1	Ring light (optional). Secondary lens not shown.
2	Ring light height adjustment

CP500/ 750 Modules

We recommend that you remove and clean the Secondary Lens as well as the Ring Light at the same time.

To clean these components:

1. Remove the module covers.
2. Loosen the Ring Light screw.
3. Remove the Secondary Lens and Ring Light.
4. Clean the the **Secondary Lens** (see "Cleaning Glass Surfaces" on page 88).
5. Clean the **Ring Light Diffuser** (see "Cleaning Plastic Surfaces" on page 92).
6. Replace these components.

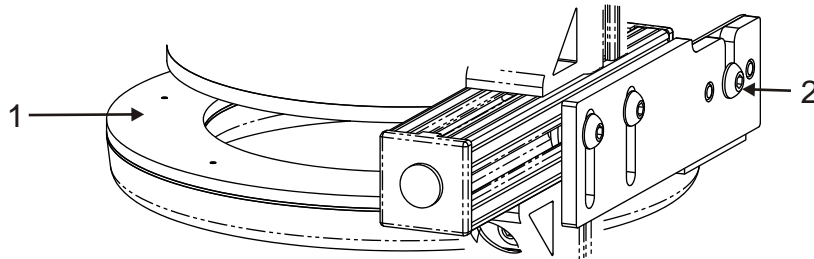

1	Ring light (optional). Secondary lens not shown.
2	Ring light screw

CLEANING PLASTIC SURFACES

Plastic surfaces that may require cleaning are:

- Dome Light Diffuser
- Ring Light Diffuser
- Light Shield (if present)
- Beam Splitter Diffuser (if present)

❖ *Note: Cleaning frequency will depend on plant and process conditions.*

To clean plastic surfaces:

Do	Do Not
Use canned compressed air to blow away dust	Do not wipe away dirt as plastic coating may be scratched
Use a clean, non-abrasive cloth dampened with mild soap and water solution. Saturate surface completely to let particles wash away.	Do not use paper towels or paper napkins – these may scratch surfaces
Dry the surface with clean, compressed air	

CP1500 Dome Light Diffuser

To clean the Dome Light Diffuser:

1. Use the wing nut (item 1) to loosen the assembly and raise the Dome and Fill Light assembly.
2. Clean the dome light diffuser.
3. Lower the module back to its original position.

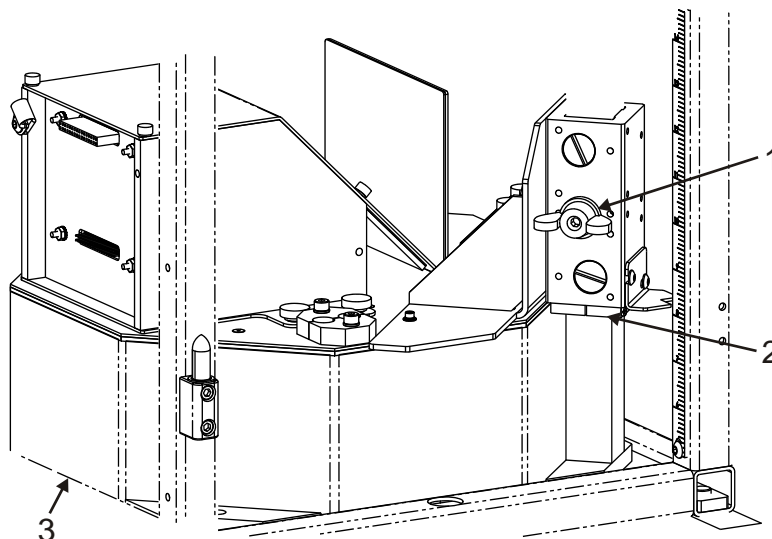

1	Height adjustment wing nut for Dome and Fill Light Assembly
2	Clamping bracket for lighting height reference
3	Dome Light Diffuser (underneath)

CP500/ 750 Dome Light Diffuser

To clean the Dome Light Diffuser:

1. Raise the module with the height adjust lever (item 1).
2. Clean the diffuser.
3. Lower the module back to its original position.

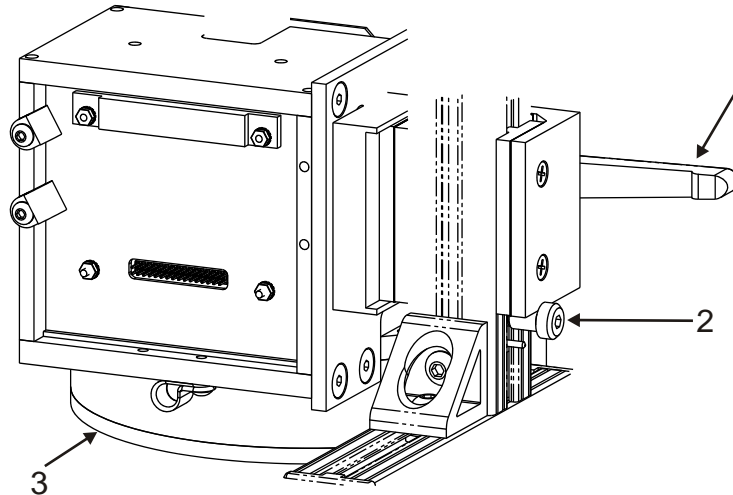

1	Height adjust lever for Dome and Fill Light Assembly
2	Clamping bracket for lighting height reference
3	Dome Light Diffuser (underneath)

Ring Light Diffuser

On the CP500/ 750 and CP1500 modules, the Ring Light should be cleaned at the same time as the Secondary Lens (if your system is equipped with one). Please refer to *Cleaning the Secondary Lens* (on page 91) for information on removal of the ring light module.

CLEANING THE ELLIPSOIDAL MIRROR

This mirror provides the enhanced neck image for optimal inspection of the neck of a can.

Warning

The special surface of the mirror can be easily scratched. Take special precautions and do not touch the surface of the mirror.

❖ *Note: This mirror does **not** require periodic cleaning. Contact Pressco Service if the mirror has dirt or marks that cannot be blown off with clean, compressed air.*

In most systems, the mirror has a built-in air cleaning system. Air is blown through the module to keep dust and debris off the mirror and out of the module. There are no bottom shields on these modules. You do not have to clean the mirror in these modules.

Modules with Plastic Shields

In some modules, protective shields cover the bottom of the ellipsoidal mirror.

The ellipsoidal mirror is enclosed in the lighting box, and covered by two plastic shields – one disposable and one permanent. These shields protect the ellipsoidal mirror from contamination.

The *plastic shields* (see "Cleaning Plastic Surfaces" on page 92) can be cleaned. If the outer plastic shield becomes scratched, it can be replaced. **Call Pressco** (see "How to Contact Pressco" on page 272) for a replacement shield.

If you have cleaned the plastic shields, the beam splitter and mirror, as well as the camera lenses, and still have dirt appearing on the image, the ellipsoidal mirror can be cleaned as a last resort.

To clean the ellipsoidal mirror:

1. Remove the plastic shield enclosing the ellipsoidal mirror.
2. Blow dust off the mirror with canned, compressed air. Make sure the can is held in the upright position and shoot the air up into the module from the bottom.
3. Replace the plastic shields to protect the mirror.

CLEANING THE PART DETECTOR

Your system will be equipped with either a part detector or proximity sensor, depending on your application. The proximity sensor does not use a reflector. However, the cleaning procedure for either of these types of sensors is similar.

The part detect sensor and reflector surfaces of the part detector must remain clean to properly detect parts. Clean these surfaces regularly to prevent dirt and oil build-up.

To clean the part detector:

- Clean the part detector surfaces with a soft, clean, lint-free cloth dampened with a mild soap and water solution.
- Clean the sensors on both sides of the conveyor.
- Do not use a glass cleaning solution or strong solvent on the plastic surfaces as they might be damaged.

❖ *Note: The frequency of cleaning will depend on plant and process conditions.*

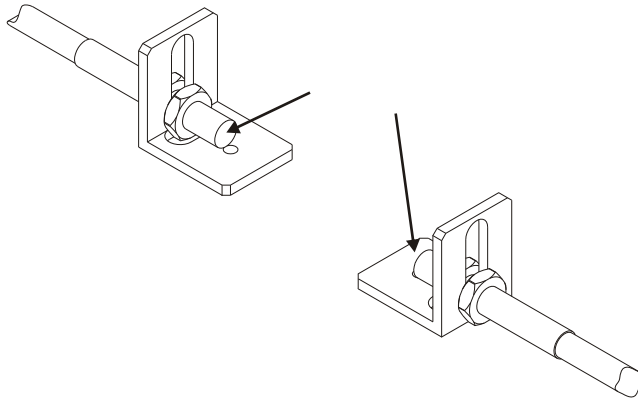

MAINTAINING THE MOUNTING ASSEMBLY

This procedure applies to the CP4401E, CP4411E, and CP4412E inspection modules. Once per month, apply oil to the shafts of the mounting assembly to prevent rusting.

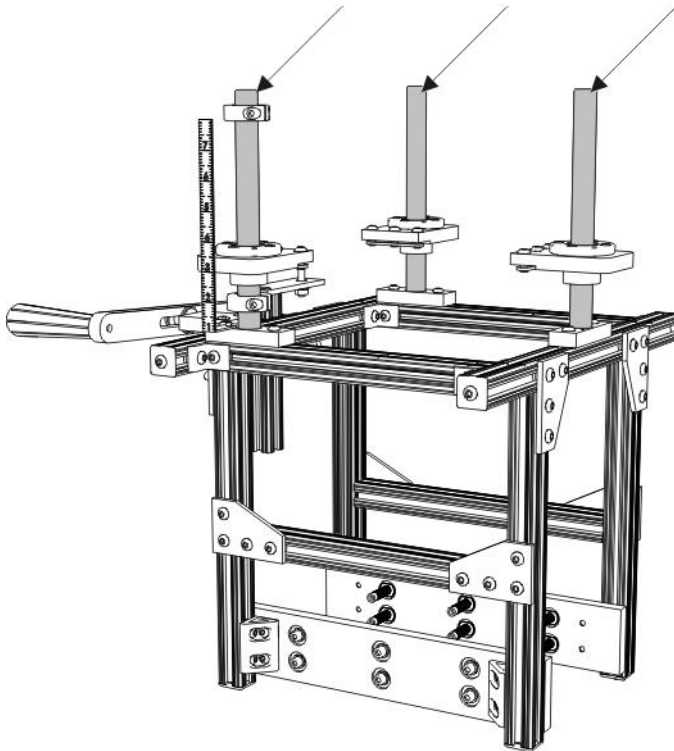

REPLACING FILTER/ REGULATOR FILTERS

The filter/ regulator assembly shown below is installed with CP4411E, CP4412E, and CP4422E inspection modules.

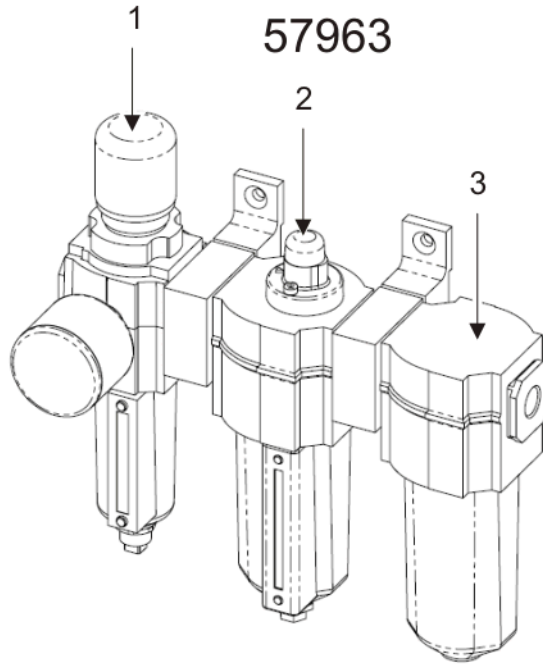

1	Filter/ regulator. No filter change necessary.
2	Filter oil coalescing. Has an indicator at the top that is normally green. The indicator turns red when the filter needs to be replaced.
3	Filter oil vapor

Use the following part numbers and replace as indicated:

Pressco part number	Description	Use in item number (above)	Replacement frequency
66218	Filter element oil removal	2	Every 2000 hours
66219	Filter element oil vapor removal	3	Every 12 months
66220	Kit (contains one each of 66218 and 66219) <ul style="list-style-type: none"> ▪ You may find it easier to replace both of these filters at the same time, when the indicator on [item 2] turns red ▪ If your plant is a heavy oil environment, replace 66218 each time the indicator turns red 		

PROCESSOR CABINET AIR FILTER MAINTENANCE

There are three air filters within the Processor cabinet. Two are mounted on the Processor Cabinet; the third is in the PC inside the Processor Cabinet. Filter removal is explained below.

❖ *Note: Some systems are equipped with air conditioners and do not have the cabinet circulation filters.*

- If filters contain only dry dust and dirt, rinse them in plain water to clean them.
 - If they contain oily dust and dirt, clean them in soapy water.
-

❖ *Note: Frequency of cleaning will depend upon plant conditions.*

Cleaning the Processor Cabinet Air Filters

The Processor Cabinet has two air circulation fans, and each has an associated filter. The fan on the lower right side of the cabinet is the intake; the fan on the upper left side is the output.

To remove and clean the filters:

1. Remove the grill vents. Refer to the illustrations below.
2. Rinse in clean water; use mild soap and water solution if oily.
3. Replace the filters and grill vents.

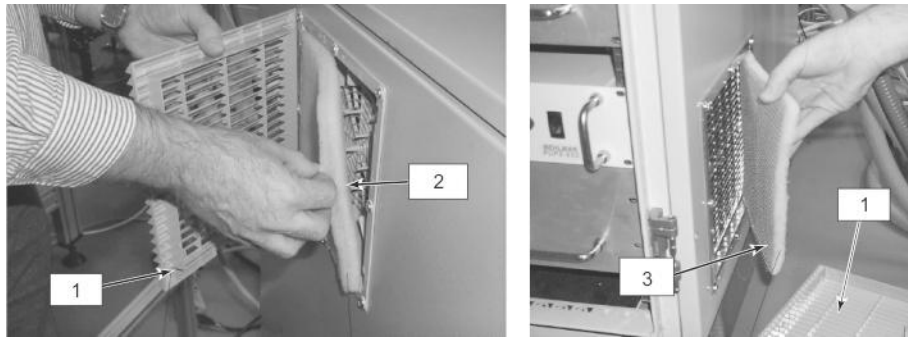

1	Grill
2	Exhaust Filter
3	Intake Filter

Cleaning the PC Air Filter

The PC (computer) has one air circulation fan and filter.

To remove and clean filter:

1. Open the front door of the Processor Cabinet.
2. Turn the panel latch to the right to open the access door on the front of the PC.
3. Grip and press in on the filter holder.
4. Slide the filter holder to the right and remove the filter.

5. Rinse in clean water; use mild soap and water solution if oily.
6. Dry filter and replace in PC.

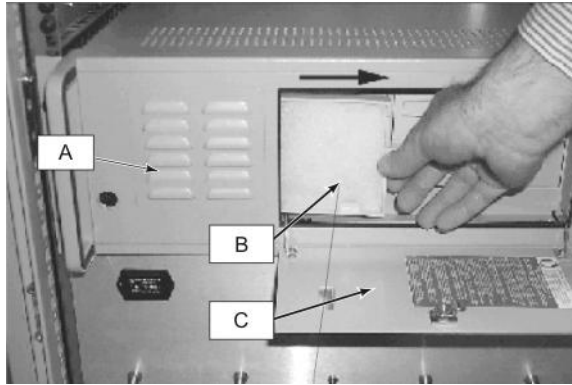

A	PC
B	Air Filter
C	Access Door

Cleaning the Air Conditioner Filter

If your system is equipped with an air conditioner, the filter must be cleaned.

To remove and clean the filter:

1. Remove the plastic grill cover.
2. Using a hex head driver, remove the retaining screw.
3. Slide the filter up and out.
4. Clean the filter.
 - If filter contains only dry dust and dirt, rinse it in plain water.
 - If it contains oily dust and dirt, clean it in soapy water.
5. Replace filter, screw, and plastic grill cover.



Chapter 9

TROUBLESHOOTING

This section provides basic troubleshooting information for the Intellispec Series IV-D and D+ Vision Inspection Systems.

TROUBLESHOOTING FLOWCHARTS

The troubleshooting flowcharts are designed to help you isolate and correct common Intellispec System problems quickly.

Each flowchart identifies a problem and asks a series of questions about the system. All questions can be answered “yes” or “no”. Answer each question in the order presented. A “yes” answer leads you down the flowchart. A “no” answer leads you to the right.

When the answered questions provide enough symptoms, the flowchart offers one or more probable causes and corrective actions. Investigate each probable cause in the order presented. When a probable cause applies to your system problem, perform the recommended corrective action(s).

Refer to the *Main I/O board layout* (see "Main I/O Board, Rear View" on page 45) for LED and test point locations.

No Power (Blue light tree lamp off)

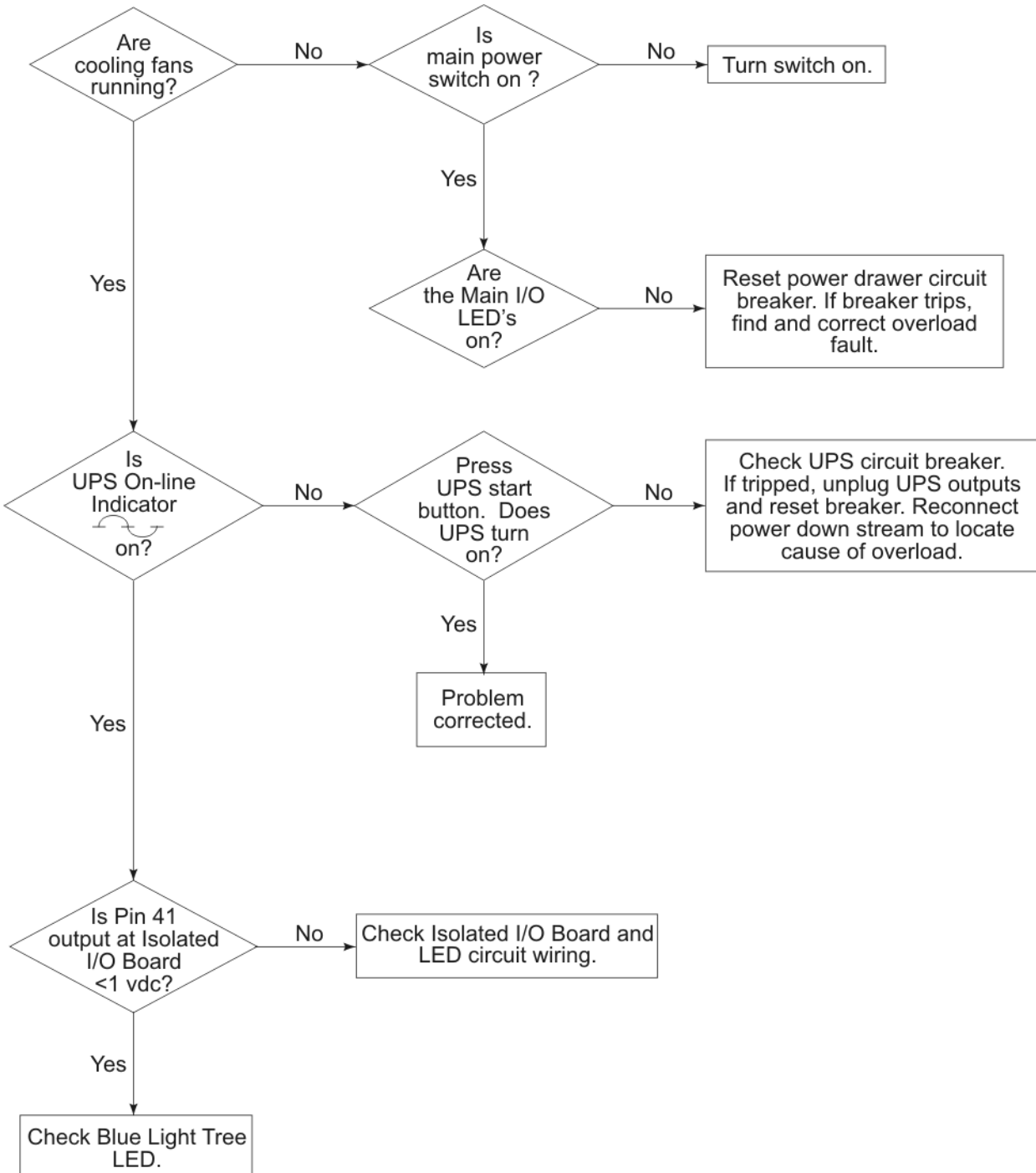

No image display, all cameras

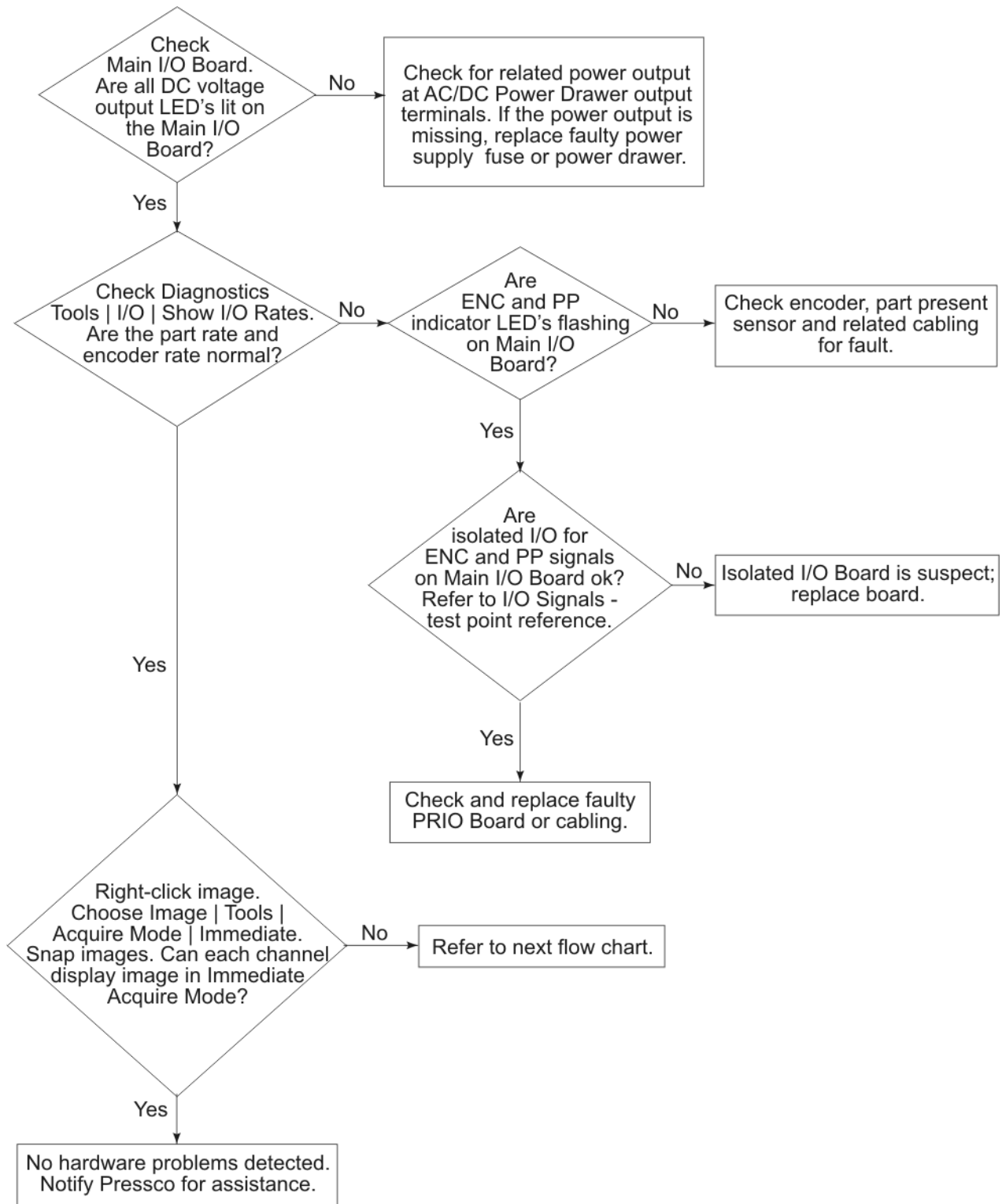

No image display, one camera

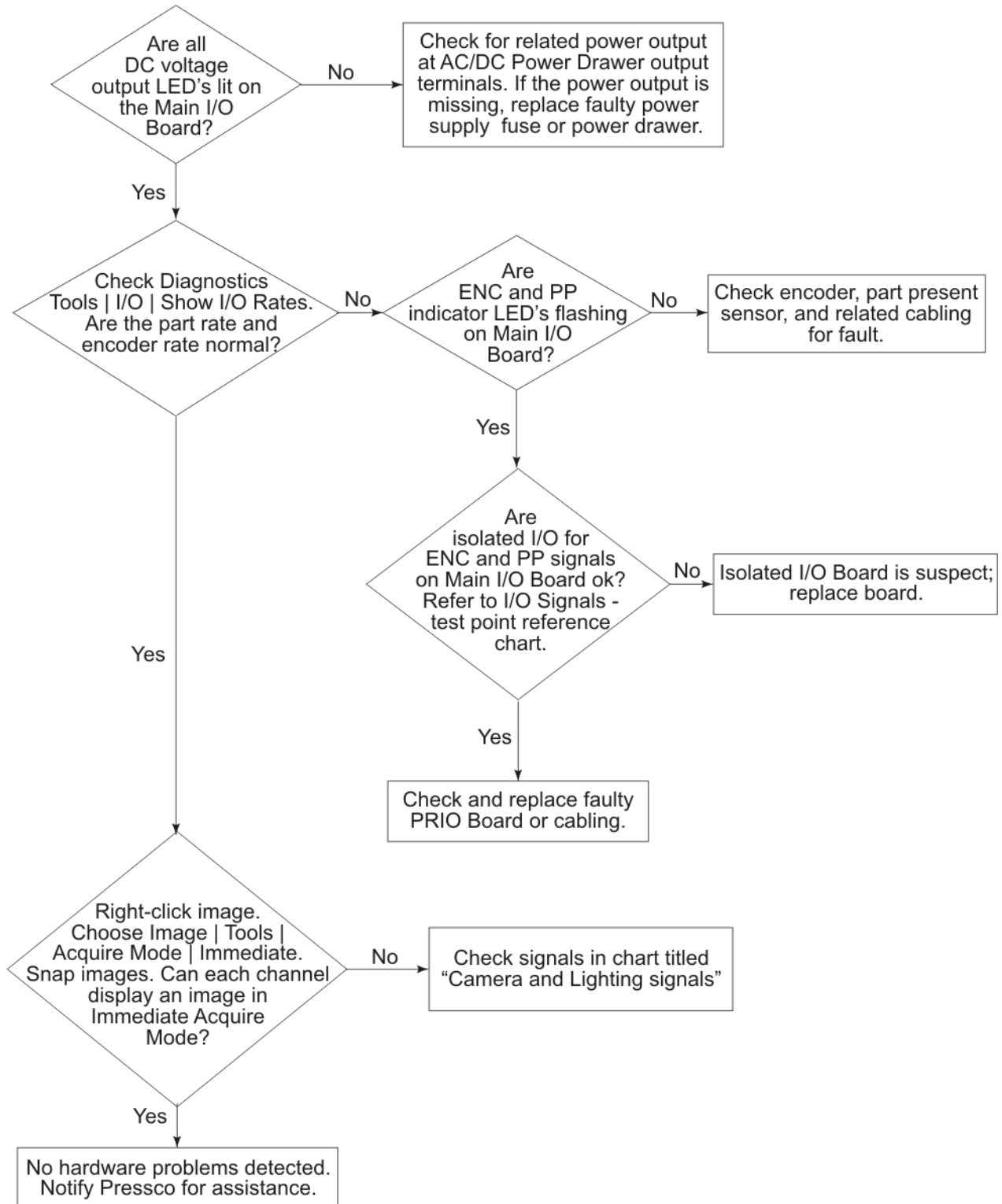

System not rejecting any parts

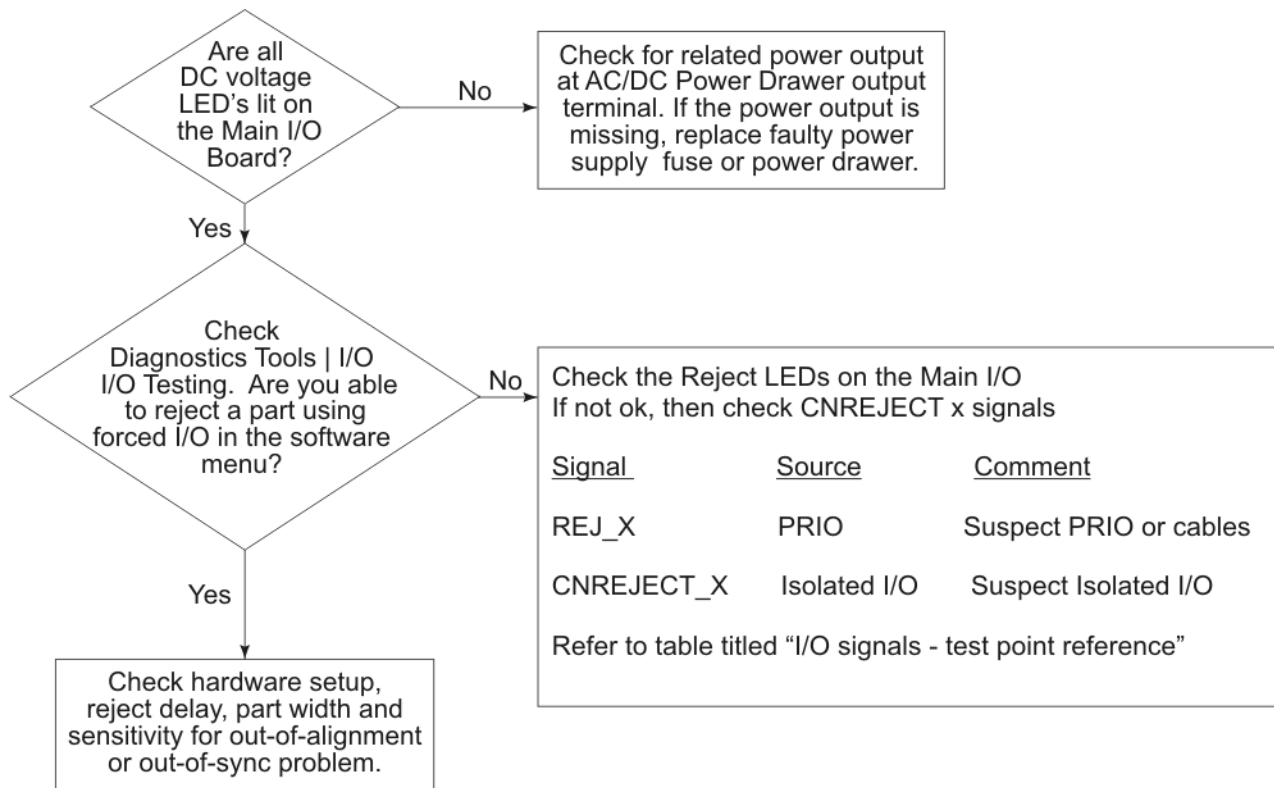

CHANGING CAMERAS IN SERIES IV-D, IV-D+ SYSTEMS

Caution

You cannot simply swap cameras in your system to troubleshoot. Refer to the following guidelines.

The digital cameras in the Intellispec Series IV-D, and IV-D+ systems all have the following properties:

MAC address

This unique address is found on the physical label attached to the camera.

IP address

The IP address is generated by the Windows® operating system (or specialized DHCP server software in some systems).

Name

Use the Pressco naming convention [Camera(x)] where 'x' is the camera number (from 1-8). The camera names must be unique and contiguous starting with '1' (example: Camera1, Camera2, Camera3, etc.).

The names are associated with the camera channels that are communicating with them. You cannot swap Camera1 with Camera2, for example - the Intellispec will locate both cameras, but the images will not be properly obtained.

The Intellispec identifies which camera to trigger based on the above addresses. The screen below shows a normal camera configuration (configured for three cameras).

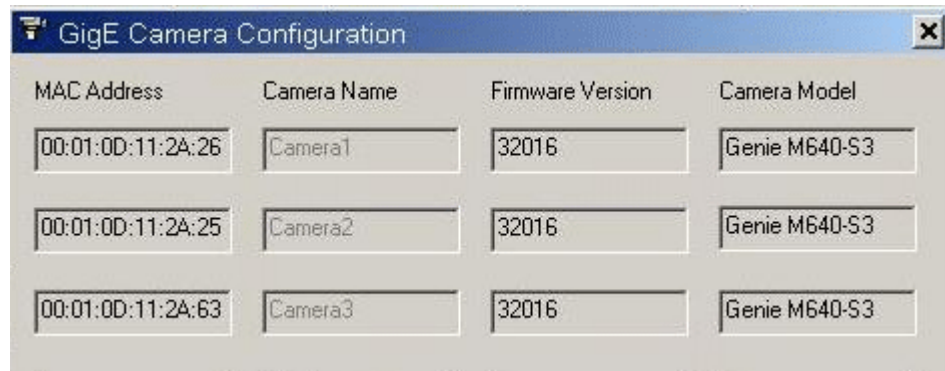

Replacing a camera

- If you replace a camera, you must properly name the replacement camera
- If you try to swap a camera from your Intellispec system to test in place of a faulty camera, you will get strange results due to potential naming conflicts

❖ *Note: We recommend that you replace a camera only with a Pressco spare camera.*

If you receive a replacement camera from Pressco, follow these steps.

To replace a camera:

1. **Shut down Intellispec** (see "How to Shut Down the Intellispec" on page 16).
2. Remove defective camera.
3. From new camera, write down MAC address, which is printed on the camera label.
4. Install new camera.
5. **Power up Intellispec** (see "How to Power Up the Intellispec" on page 17).
6. When the camera configuration box appears, type in the name of the new camera (example, Camera3). Be sure to use the exact name of the camera that is being replaced.
7. Verify that the new camera's MAC address in the GigE Camera Configuration screen is the same as the one you wrote down before you installed the camera.

Example error messages

The screen below shows an error where the system did not find all the cameras it expected to find, based on the system configuration. In this case, you would need to check the physical connection to Camera1, or perhaps Camera1 needs to be replaced. This screen appears when the Intellispec senses a new camera.

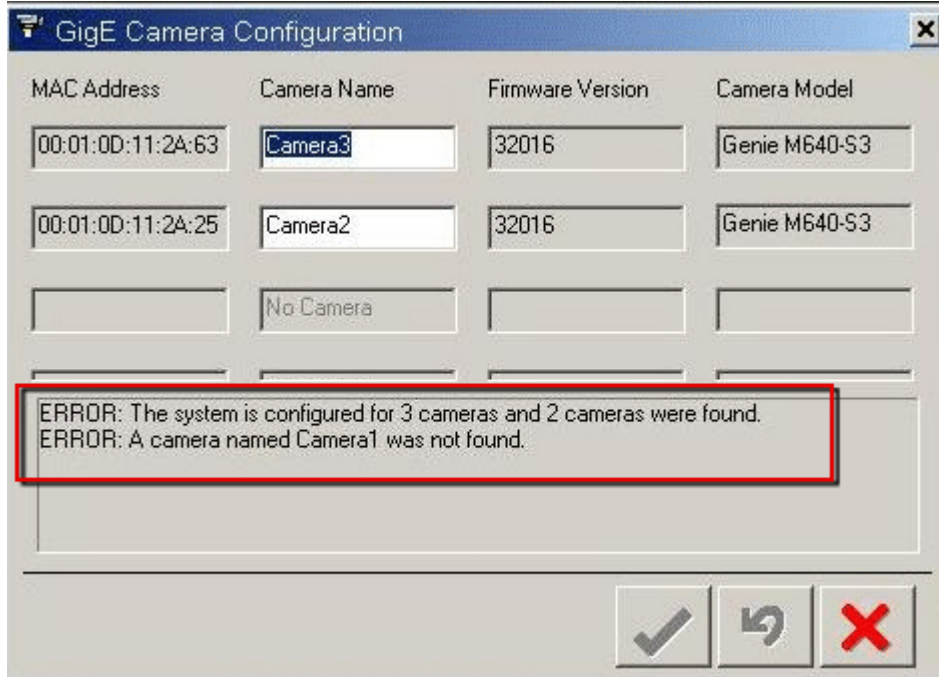

The screen below shows an error where the system could not identify one of the cameras because it has not been named properly. In this case, you should re-name the [S4274359] camera to "Camera2".

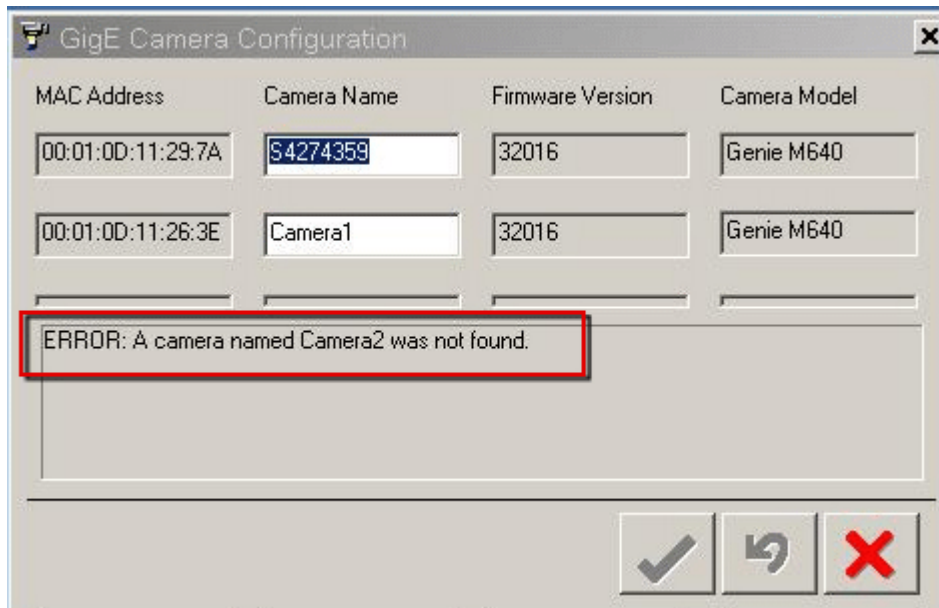

ADDITIONAL TROUBLESHOOTING HINTS

Refer to the following topics for additional input when troubleshooting inspection system faults.

No Image Display

- If this fault occurs both online and offline, shine a flashlight into the camera view finder to verify that the camera can make an image.
- If the strobe lights flash during an image acquisition attempt, shine a flashlight into the camera view finder to verify that the camera can make an image.
- Verify DC power levels and the presence of DC voltages at the camera module(s).

System Not Rejecting Any Parts

USER LEVEL: ADMINISTRATOR

- Use the System Configuration Menu | Channel Groups | group | Reject tab to see if Reject is enabled. Then check System Configuration | Channel Groups | group | Calibration to verify that the Reject Delay and Part Width are set to the correct values.
- In systems installed with blowmolders, go to the Alarms Menu and enable both the Chute Full and Door Open alarms. Then try the step below:
- (All systems) Go to System Configuration | Channel Groups | group | Reject tab to set Missed Parts to Always Fail. Restart the system. If the problem goes away after taking system Offline and Online again, notify Pressco.

System Rejecting Good Parts

- If tabular inspection results show that inspections are not failing, view the Missed Parts Statistics in the System Information tab for Missed Parts. If there are occurrences, check the System Configuration Menu | Channel Groups | group | Reject tab for Missed Parts designated as Always Fail.
- If Missed Parts are occurring, check for a part detector sensor misadjustment or a dirty reflector plate. Also check for an incorrect Part Present Delay value in the System Configuration Menu | Channel Groups | group | Channel tab | channel | Tracking tab.
- If Missed Results are occurring, compare the inspection time to the reject delay. If the inspection time is too long, try to shorten the inspection time. If the inspection time can not be shortened, disable the displaying of inspection regions on failed parts (right-click image | choose Image Display Options | and choose Show No Regions for Graphics Display).
- If inspections are failing some good parts, check the Reject calibration to verify that the correct part is being rejected (System Configuration | Channel Groups | group | Reject tab).

System Rejecting All Parts

- Verify that the inspection algorithms are not rejecting all parts.
- Verify that all Part Present Delays are shorter than the Reject Delays in the System Configuration Menu | Channel Groups | group | Channel tab | channel | Tracking tab (part present delay). Reject Delay is located under System Configuration | Channel Groups | group | Reject tab. The Reject Delay must also accommodate the imaging time and inspection time. See the Results tab when running a job to view inspection time.

Miscellaneous Checks

Review and use the following miscellaneous checks when troubleshooting the Intellispec System.

- Check Part Present signals when machine is running.
- With system Offline, monitor outputs via Diagnostics Tools | I/O | I/O testing. Click the desired output button to toggle the output on and off.

Additional Checks

- The entire system may appear dead when a fault occurs in the VGA card or monitor.
- Check voltages to camera modules.
- Check system signals according to the information provided in tables on the following pages.
- If all but one of the +/- differential signals are as expected, disconnect the suspect signal cable from the Main I/O Board (J4, J5, J10, or J11). If the faulty signal is now good, the problem is most likely a faulty cable connection, a bad cable, a bad umbilical to the camera module, or a faulty camera module.

Many of the signals and test points referenced in the preceding troubleshooting procedures are available on the **Main I/O Board** (see "Main I/O Board LEDs and Test Points" on page 48), the **Isolated I/O PCB** (see "Main I/O Daughter Board Pinouts" on page 57), and the **Camera Personality PCB** (see "Main I/O Daughter board pinouts 2" on page 58).

Also refer to the **wiring diagrams** (see "Wiring Diagrams - Processor Cabinet S IV-D, D+" on page 61).

Chapter 10

CHROMAPULSE™ INSPECTION THEORY

OVERVIEW AND THEORY

Patented Technology: The Chromapulse Inspection Module is based upon Pressco's patented pulsed solid state light source with programmable spectrum control. The system provides software controlled multi-color, multi-directional lighting which yields camera images with optimum defect contrast. This is especially beneficial on parts having multi-colored patterns, inconsistent geometry, and variable surface reflectivity.

Color Spectrum Control: A fully configured Chromapulse light system contains four different light colors: Red, Green, Blue and Infrared. (Infrared is invisible to the human eye.) Through software control, individual colors can be mixed making it possible to create any desired color. The particular light colors included in a system can vary depending on application requirements.

Multi-Directional Light: Chromapulse includes programmable control over the direction of the light. This enables optimal illumination of parts with varied geometry. Specific geometric features such as curls, countersinks, lugs and beads can be illuminated from the proper direction to yield optimal defect contrast.

Programmability: The programmability of the light color and direction provide the flexibility to inspect parts with a wide variety of color and geometric characteristics. The setup can be configured to accentuate defects as well as mask acceptable process anomalies. Various illumination setups can be saved and recalled.

❖ *Note: Refer to Intellispec Programming Guide for information about the Light Control Tool.*

Using the CP1500 inspection module as an example, a fully loaded CP1500 Chromapulse light system consists of:

- a fill light.
- a dome shaped light consisting of three sub-sections.
- a ring light.

The Chromapulse light source is divided into sections. The light source is divided into five sections: Fill Light, Upper Light, Middle Light, Lower Light and Ring Light. The number and position of the sections can vary depending on the particular application.

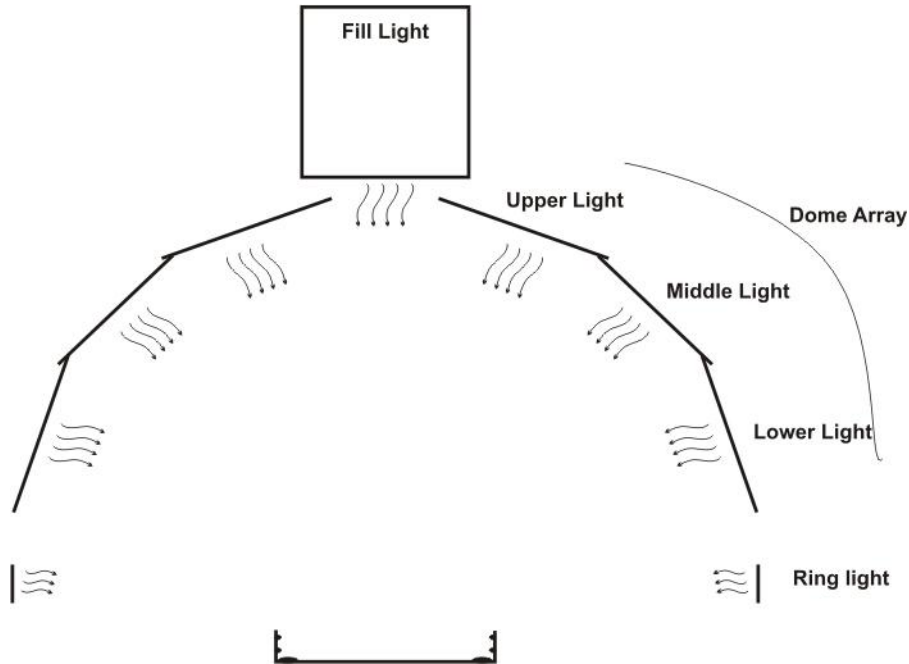

Each section is independently controllable. You can control the intensity of light from each section. In multi-color light sources, you can also control the color of light from each section.

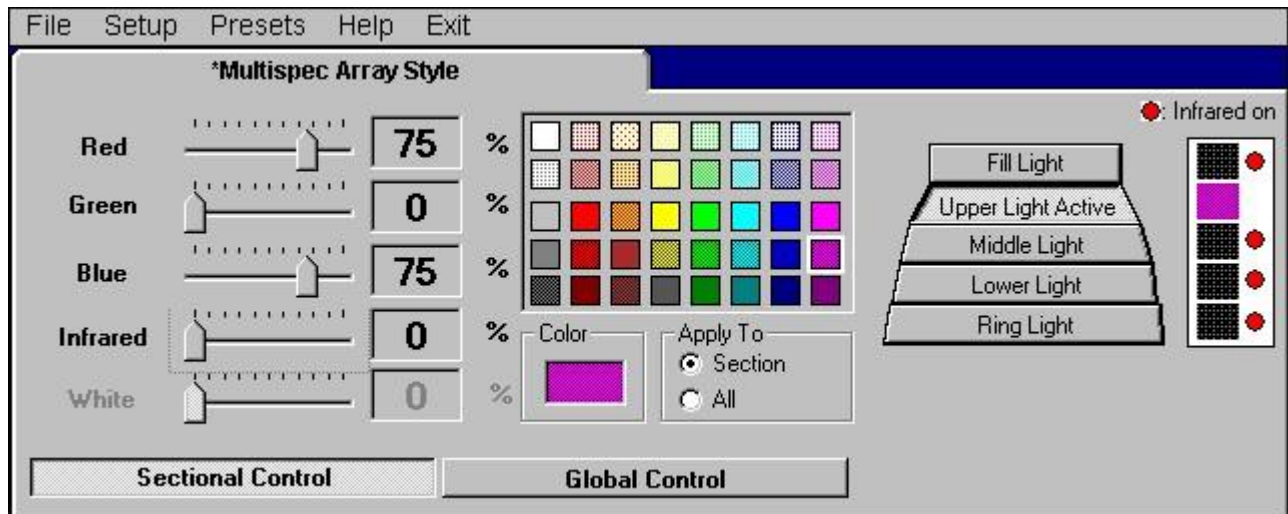

Each section is further divided into zones. A zone is a group of color of lights within a section. It is the smallest controllable portion of the light system. Each zone is also independently controllable. You can control the intensity of light from each zone. The color within a zone is fixed.

See the beginning of each inspection module chapter for a table of sections and zones of lights available.

- ❖ *Note: Some Inspection Modules may not have all four colors of lights. Applications that don't require all colors may only have the needed color lights.*
-

Lighting Setup Tips

Keep in mind that the objective, when adjusting the system, is to achieve an image that has optimal defect contrast. In order for defects to be detected, they must “stand out” – i.e., have contrast against their background. Also, if the part has acceptable process anomalies with significant contrast, the lighting may have to be adjusted to minimize these. There are two main types of adjustments:

- The programmable lighting adjustments which are controlled through the software Light Control. These include setting the light color, intensity and angle. Refer to the Intellispec Programming Guide for information on Light Control.
- The mechanical adjustments of the lights and camera. These include setting the position of the camera and lights, as well as adjusting the camera aperture and focus. These adjustments are discussed in the individual inspection module chapters.

Intensity and Image Blur

Under certain circumstances, image blur can occur. The risk of image blur is greatest when the line speed is fast and the light intensity is high. If image blur occurs, you may need to reduce light intensity and open the camera's aperture. You may need to re-focus the camera after adjusting light intensity.

- ❖ *Tip: test the image by viewing it when the part is standing still and when the line is moving. You may have a sharp image when the part is standing still, but it could be blurry when the production line is moving. Adjust for best focus in both conditions.*
-

Accentuating and Hiding Part Features

Different light colors accentuate product features differently. For example, on a shiny gold colored food end, one color light may accentuate the grain in the metal stock more than another color. Also, one color light may accentuate lines in the coating more than another color. If the metal grain or the lines in the coating are acceptable process anomalies, then you may want to choose a color of light that does not accentuate these features.

The illustration below shows the same lined shell under conventional lighting (left) and Chromapulse lighting optimized for best defect contrast (right).

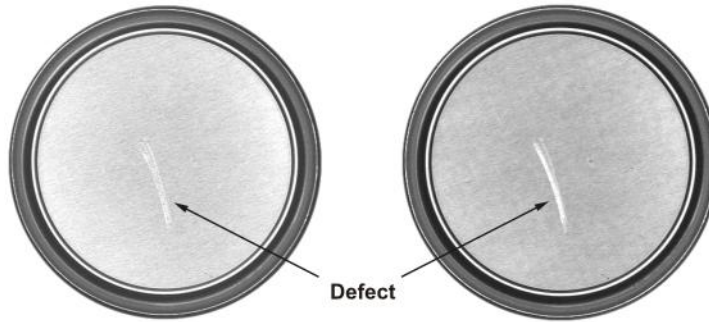

Conventional

ChromaPulse

You can hide or mask acceptable features which might otherwise interfere with detection of defects. Generally, to hide certain features, use a color of light that is the same as the color of the feature. The illustration below shows the same twist closure under conventional lighting (left) and Chromapulse lighting (right) optimized to hide the acceptable printed lines and make the defect more visible.

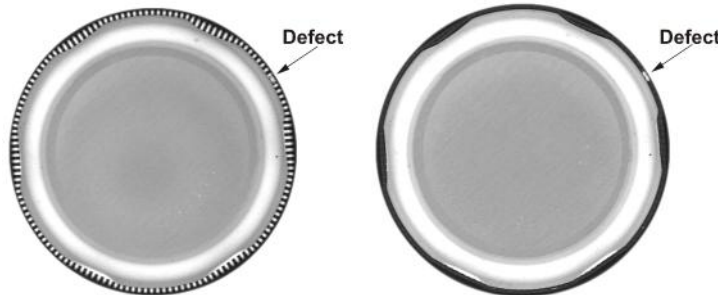

Conventional

ChromaPulse

The illustration below shows the same converted end under conventional lighting (left) and Chromapulse lighting (right) optimized to hide the acceptable printed graphics and make the defect more visible.

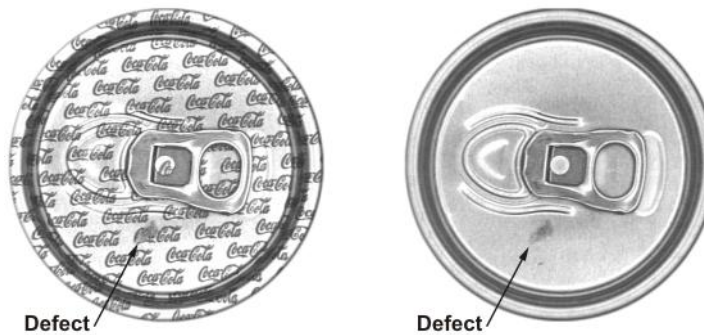

Conventional

ChromaPulse

The illustration below shows the same dark-colored plastic closure under conventional lighting (left), and Chromapulse lighting (right), optimized to make the defects more visible.

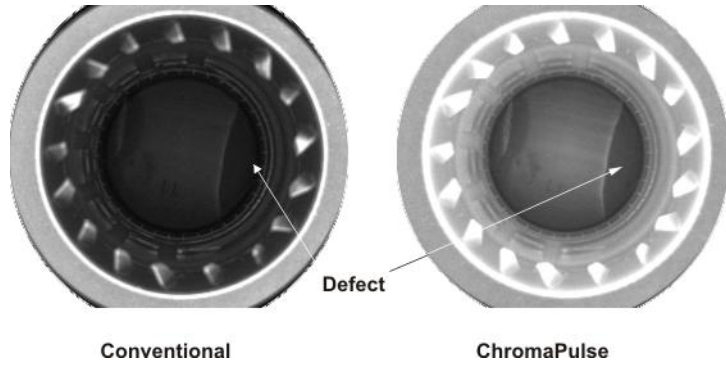

The example below shows the same spotted plastic closure under conventional lighting (left), and under Chromapulse lighting (right), optimized to make defects more visible, without confusing them with the part's natural coloring.

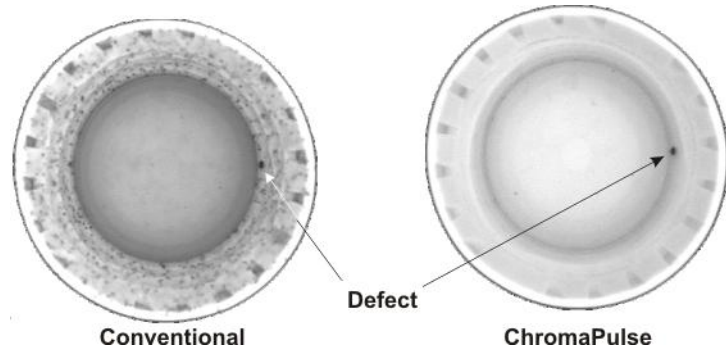

Below are more examples of conventional vs. Chromapulse lighting.



**Conventional
Lighting**



**CHROMAPULSE™
Lighting**

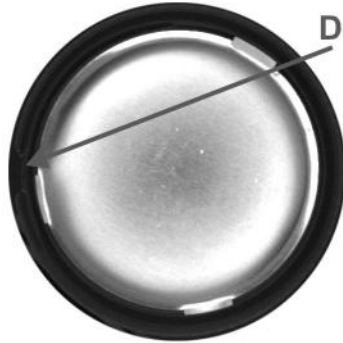

**Conventional
Lighting**

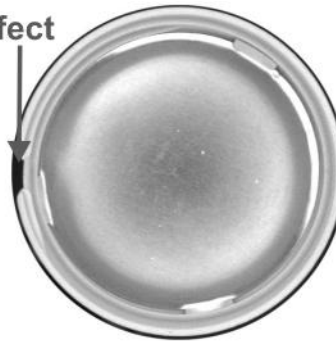

**CHROMAPULSE™
Lighting**

Chapter 11

CP500, CP750 MODULES

DESCRIPTION

These inspection modules inspect a variety of products. The CP500 inspects mostly 28mm crowns and closures. The CP750 and CP750E inspect lined shells, converted ends, food ends, EZO ends, plastic closures, and other products. The main differences between the CP500 and CP750 are the size of the inspection module and the shape of the lighting arrays. The CP750 and CP750E have different shapes.

❖ *Note: The newer CP750E is a different shape – refer to CP/E Series Modules (on page 167).*

These modules use one camera and several **lighting zones** (see "Lighting Zones CP500, CP750" on page 117). The camera and lighting zone configuration for CP500, 750, and 750E are the same; however, the angle of the lighting array of the CP500 is different than that of the CP750 or CP750E.



Lighting Zones CP500, CP750

The information below is applicable to CP500/ CP500E/ CP750/ CP750E inspection modules.

These modules use one camera and several lighting zones (see below). The camera and lighting zone configuration for CP500E and CP750E are the same; however, the angle of the lighting array of the CP500E is different than that of the CP750E. The illustration below shows the zone grouping for these modules.

These zones are programmed at Pressco and should not be changed. You may view the setup in Lighting Control > Setup > Array Configuration.

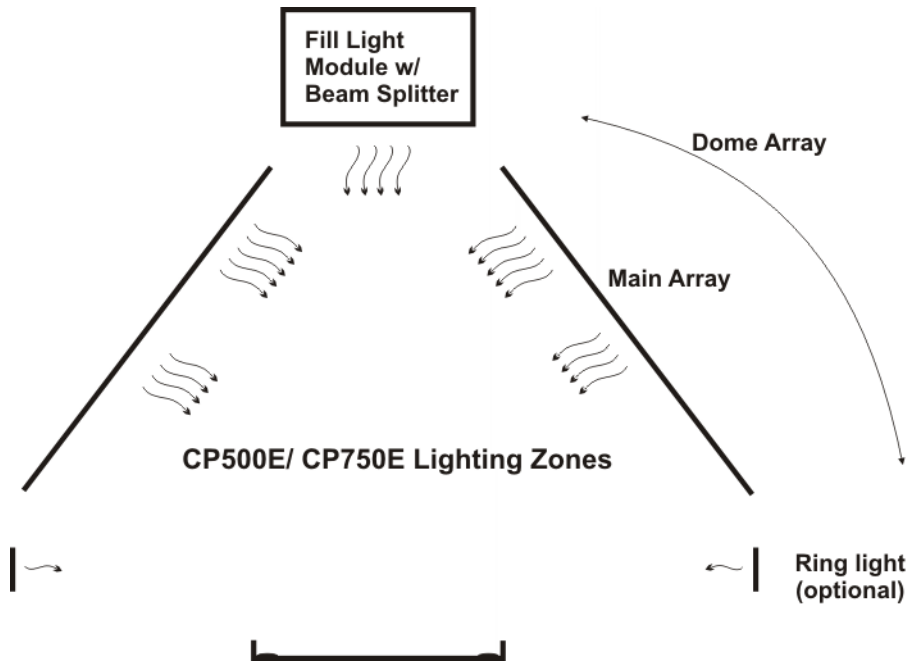

CP500E/ CP750E lighting zones		
Fill light with beam splitter (may not be present)	Main array	Ring light
4 zones: <ul style="list-style-type: none"> ▪ 1 red zone ▪ 1 green zone ▪ 1 blue zone ▪ 1 IR zone 	9 zones: <ul style="list-style-type: none"> ▪ 3 red zones ▪ 2 green zones ▪ 2 blue zones ▪ 2 IR zones 	1 zone: <ul style="list-style-type: none"> ▪ 1 red zone

SYSTEM LEVEL INTERCONNECT CP750 SERIES IV

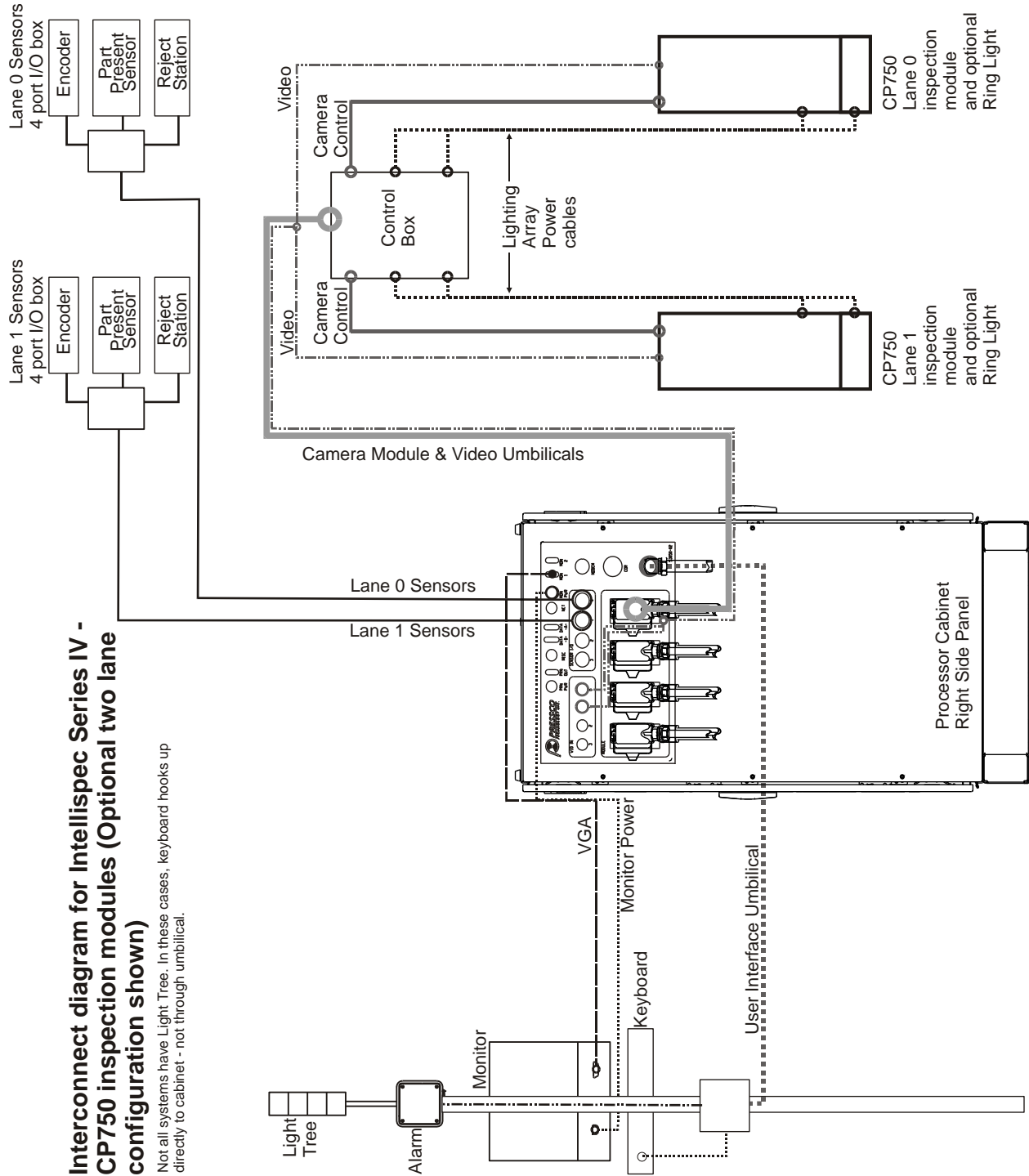

ADJUSTING THE CP500 OR CP750 INSPECTION MODULE

This section covers camera adjustments that may be required to keep the inspection modules working properly. Adjustments include the camera position, aperture, and camera focus.

The focus adjustment controls the clarity of the image; the aperture adjustment controls the amount of light admitted by the shutter. Normally the inspection modules do not require further adjustment after initial system setup. Circumstances that might require additional adjustments are camera replacement, strobe replacement, or a substantial change in part size or color.

DANGER

The inspection modules are mounted near moving machinery. Use extreme caution to avoid contact with moving machinery when servicing inspection modules as serious personal injury could result. Ensure machinery is in an emergency stop state before servicing inspection modules.

The CP750 inspection module and adjustments are shown below. The CP500 has the same adjustments. The difference between these modules is the diameter and shape of the lighting array. The procedures to adjust the components are discussed on the next several pages.

Adjustments available for the CP500/ CP750 Inspection Module include camera focus, aperture, image size, and camera height. Certain models contain motorized focus and aperture adjustments; these do not require manual adjustment - use the Camera Control Tool in the software.

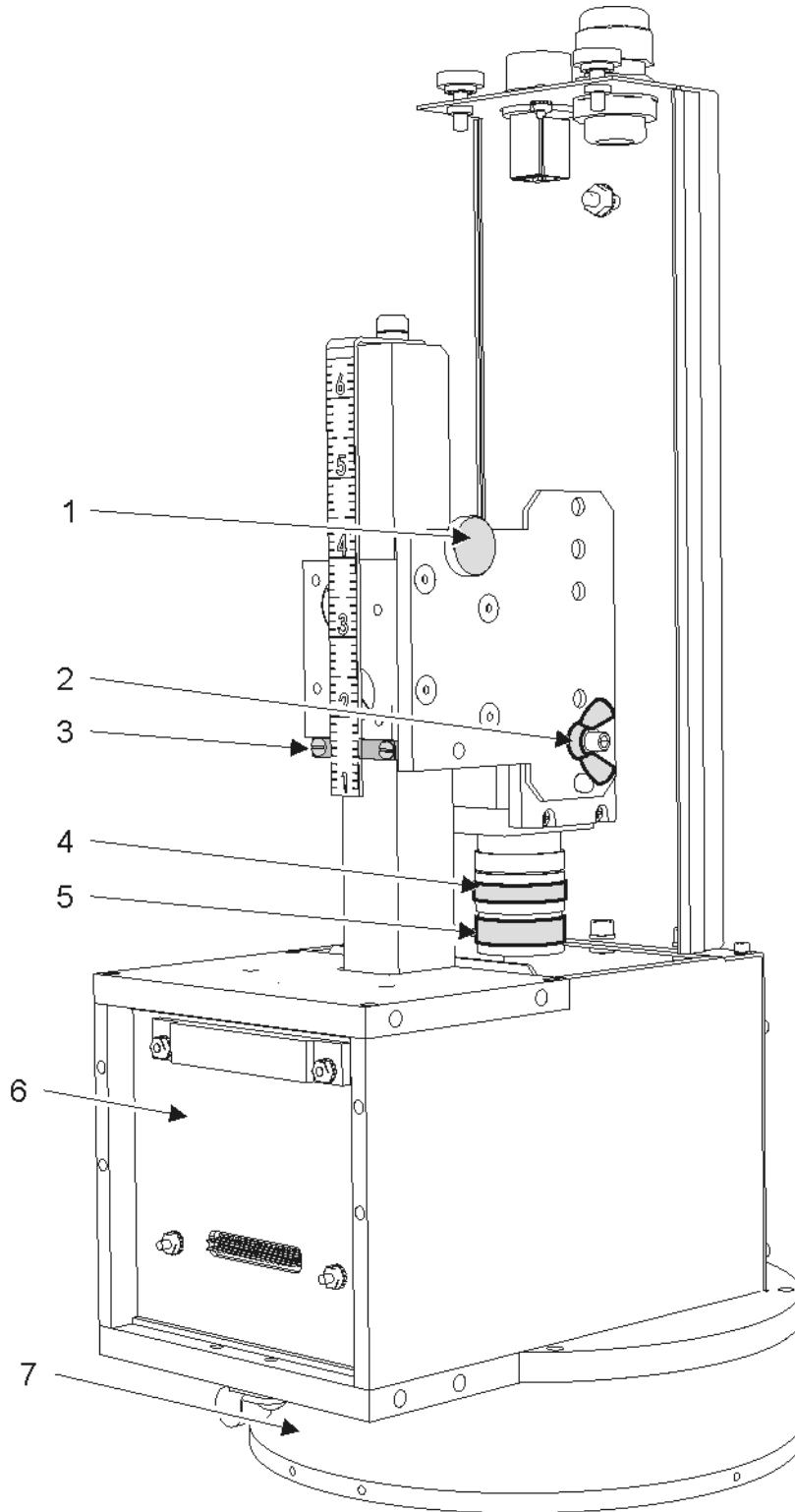

1	Camera height adjustment
2	Wing nut - camera quick-disconnect
3	Clamping bracket for camera height reference
4	Focus adjustment - may be different on other lenses
5	Aperture adjustment - may be different on other lenses
6	Fill array - not present on all models
7	Ring light - not present on all models

Module Height Adjustment

An adjustment is provided for controlling the height of the inspection module to accommodate different part geometries. Normally the CP500/ CP750/ CP750E module does not require adjustment after initial setup. However, camera replacement, or a large part size change may require readjustment.

Simply loosen the module height adjustment lever, move the module up or down while observing the part image on the monitor, and tighten the lever. The shoulder screw should remain in place after initial installation setting. This provides proper module height reference.

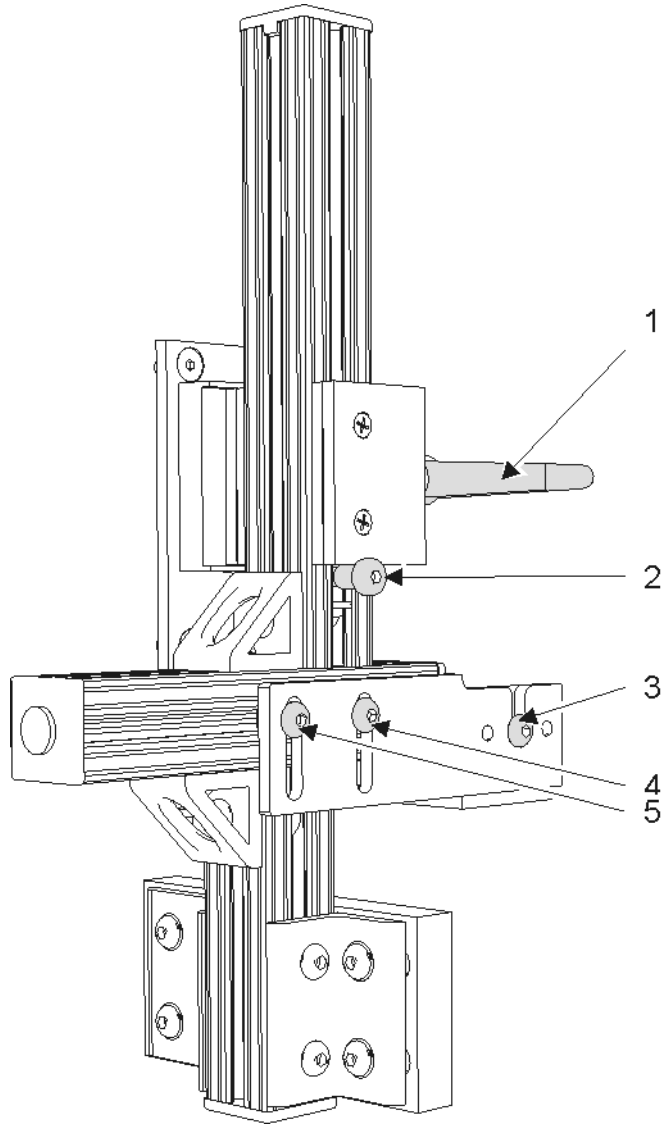

1	Module height adjustment
2	Shoulder screw for height reference
3	Ring light removal screw for cleaning
4, 5	Ring light position adjustments

Observe Part Image

When adjusting the focus, aperture, or height, it is helpful to place the Intellispec System in the Live Image mode so you can immediately see the effect of an adjustment on the image quality.

With the system Offline, choose the correct camera view > right-click the Snap button > and choose  Live Images. If the production line is not running, place a part in the camera view as it would be during normal production.

Camera Adjustments

Focus Adjustments

To adjust focus, carefully remove or open the inspection module cover. Turn the focus adjust ring while observing the part image on the monitor. Adjust the focus for the sharpest image. If needed, adjust the **aperture** (see "Aperture Adjustment" on page 124), then reinstall the cover.

Camera Height Adjustment

❖ *Note: Normally, you do not need to adjust camera height. Adjust only if you are installing, or have replaced the inspection module.*

The height of the camera affects the size of the part image. Adjust the **camera height** (see "Adjusting the CP500 or CP750 Inspection Module" on page 120) by loosening the camera height adjust screw, and moving the camera assembly up or down.

The clamping bracket should remain in place after initial installation setting. This provides a height reference to ensure that the camera remains at the proper height for inspection.

Lighting Adjustments

Aperture Adjustment

The aperture controls the amount of light that passes through the lens. The programmable light source provides the range of light intensity required for most applications. However, you can manually adjust the aperture if necessary by turning the aperture adjust ring on the camera lens. Reinstall the cover.

Adjust Lighting Through Software

Using SmartLight in the software, adjust the lighting to optimize the contrast of the defects. Also refer to **lighting setup tips** (on page 113).

❖ *Note: After adjusting lighting, you may have to re-adjust the camera focus and/ or aperture. It may take some back and forth adjustment between lighting and focus to achieve an optimal image.*

MAINTENANCE OF CP500, CP750, CP750E MODULES

Refer to maintenance procedures, with attention to the following sections:

Clean the following surfaces as often as indicated in the **table** (see "Maintenance Frequency" on page 87):

- **Glass surfaces** (see "Cleaning Glass Surfaces" on page 88)
 - **Camera lens** (see "Cleaning the Camera Lens" on page 89)

- **Beam splitter** (see "Cleaning the Beam Splitter" on page 89)
- **Secondary lens** (see "Cleaning the Secondary Lens" on page 91) (if applicable)
- **Plastic surfaces** (see "Cleaning Plastic Surfaces" on page 92)
 - **Dome light diffuser** (see "CP500/ 750 Dome Light Diffuser" on page 94)
 - **Ring light diffuser** (on page 94)
- **Part detector** (see "Cleaning the Part Detector" on page 95)
- Cabinet and pc **air filters** (see "Processor Cabinet Air Filter Maintenance" on page 98)

Chapter 12

CP4402, CP4410 BELVAC MODULES

DESCRIPTION

The CP4402 is designed to fit inside a Belvac canmaking machine. It inspects the flange and neck of inside of beverage cans, using two cameras. An installed module is pictured below.

The CP4410 is also designed to fit inside a Belvac canmaking machine. It inspects the sidewall and dome (body) of the inside of beverage cans, using one camera.

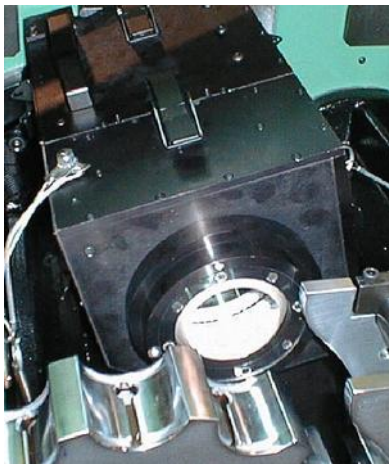

Lighting Zones: CP4402E, CP4410E

The illustrations below show the lighting zone grouping for the CP4402E and CP4410E inspection modules. These also apply to CP4402 and CP4410 inspection modules.

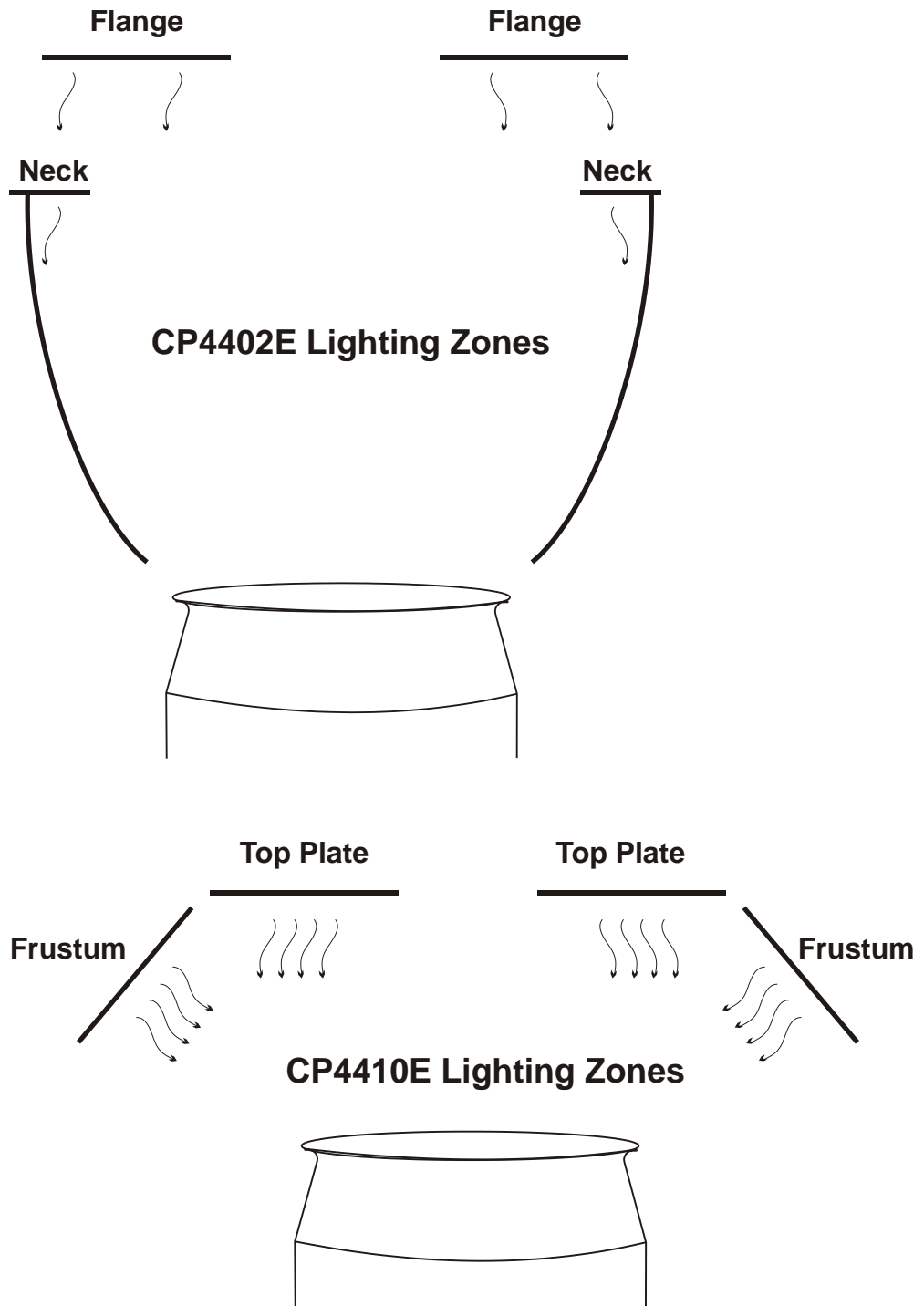

The table below shows the zone grouping for the CP4402E and CP4410E inspection modules. The intensity of each zone group is adjustable through SmartLight software.

The color of the arrays and filters on the cameras dictate what color the camera sees. In the CP4402E, the Neck camera sees only red light. The Flange camera sees only blue light.

❖ *Note: These zones are programmed at Pressco and should not be changed. You may view the setup in Lighting Control >> Setup >> Array Configuration.*

Part material type	Top plate (upper array type)	Frustum (lower array type)	Flange (ring array type)	Neck (ring array type)
Steel	8 red zones	8 red zones	2 zones: ▪ 1 red zone ▪ 1 blue zone	1 red zone
Either steel or aluminum	8 white zones	8 white zones	2 zones: ▪ 1 red zone ▪ 1 blue zone	1 red zone
Aluminum	8 blue zones	8 blue zones	2 zones: ▪ 1 red zone ▪ 1 blue zone	1 red zone

BELVAC INTERCONNECTION DIAGRAMS

COMPONENT LAYOUT

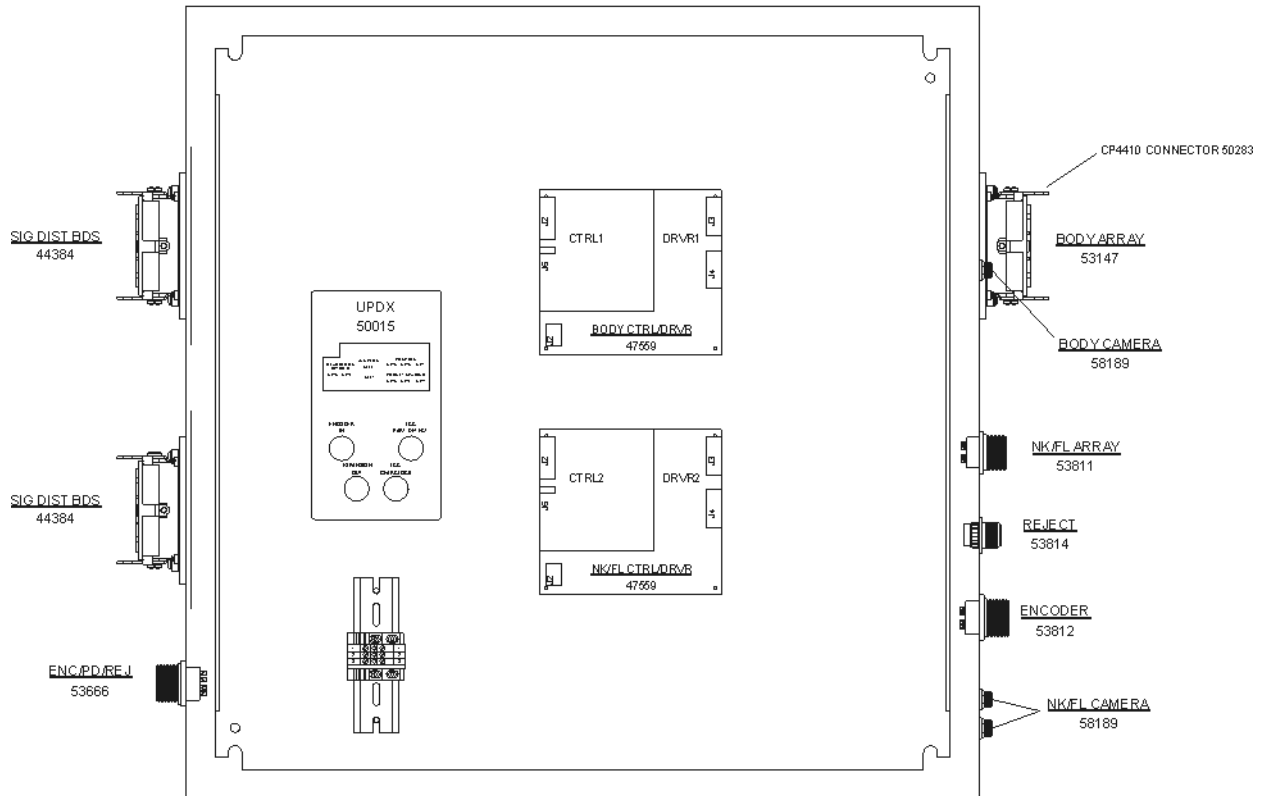

Array/ Camera control interconnect

ARRAY/CAMERA CTRL INTERCONNECT

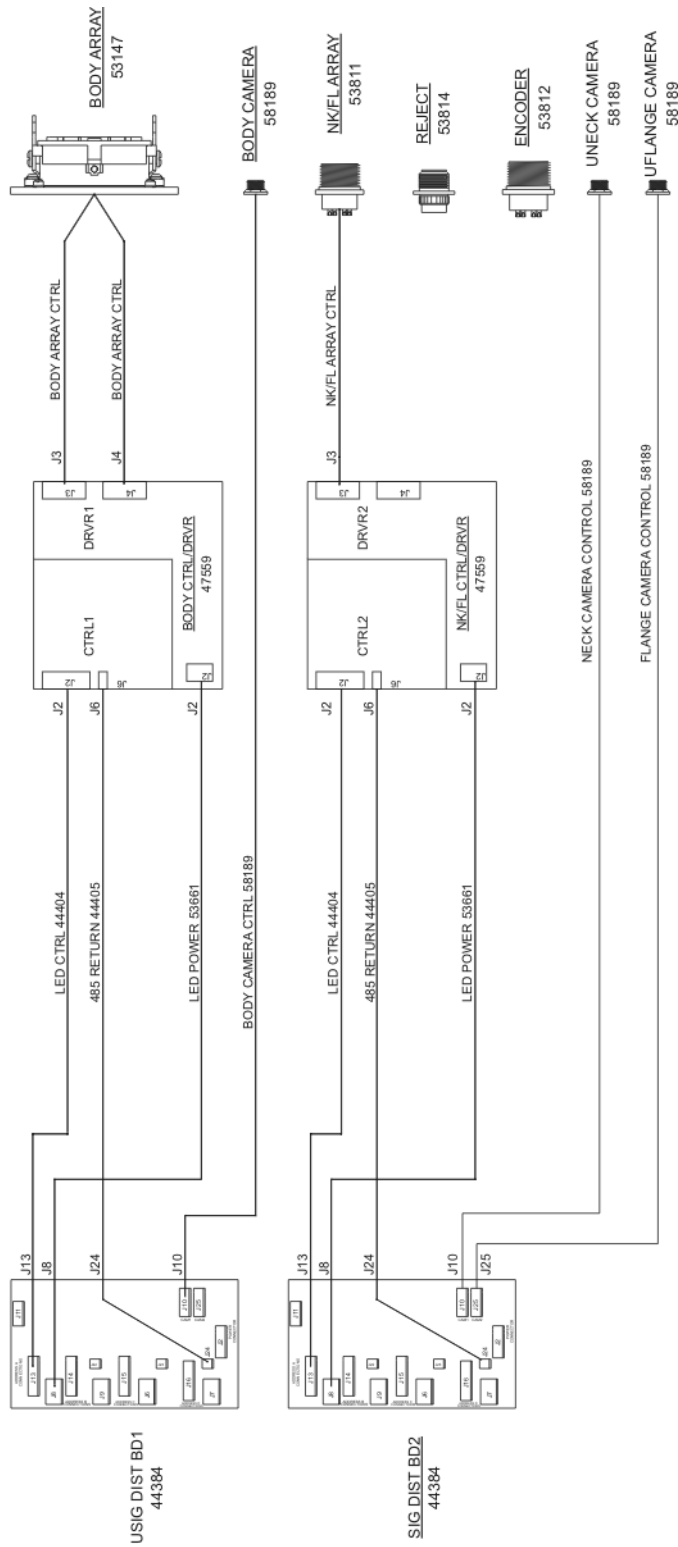

Video cable interconnect

VIDEO CABLE INTERCONNECTS

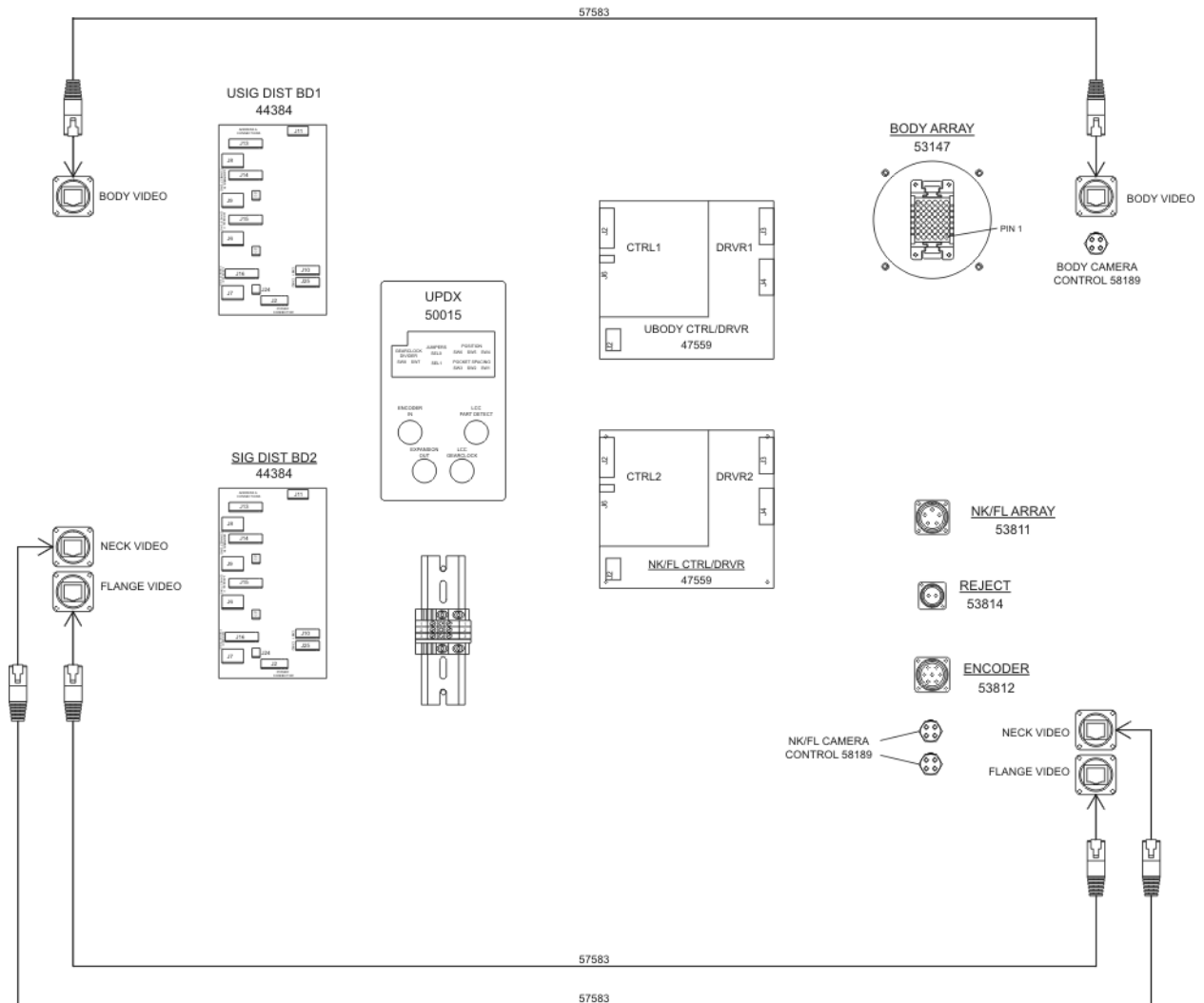

Encoder, part detect, reject interconnect

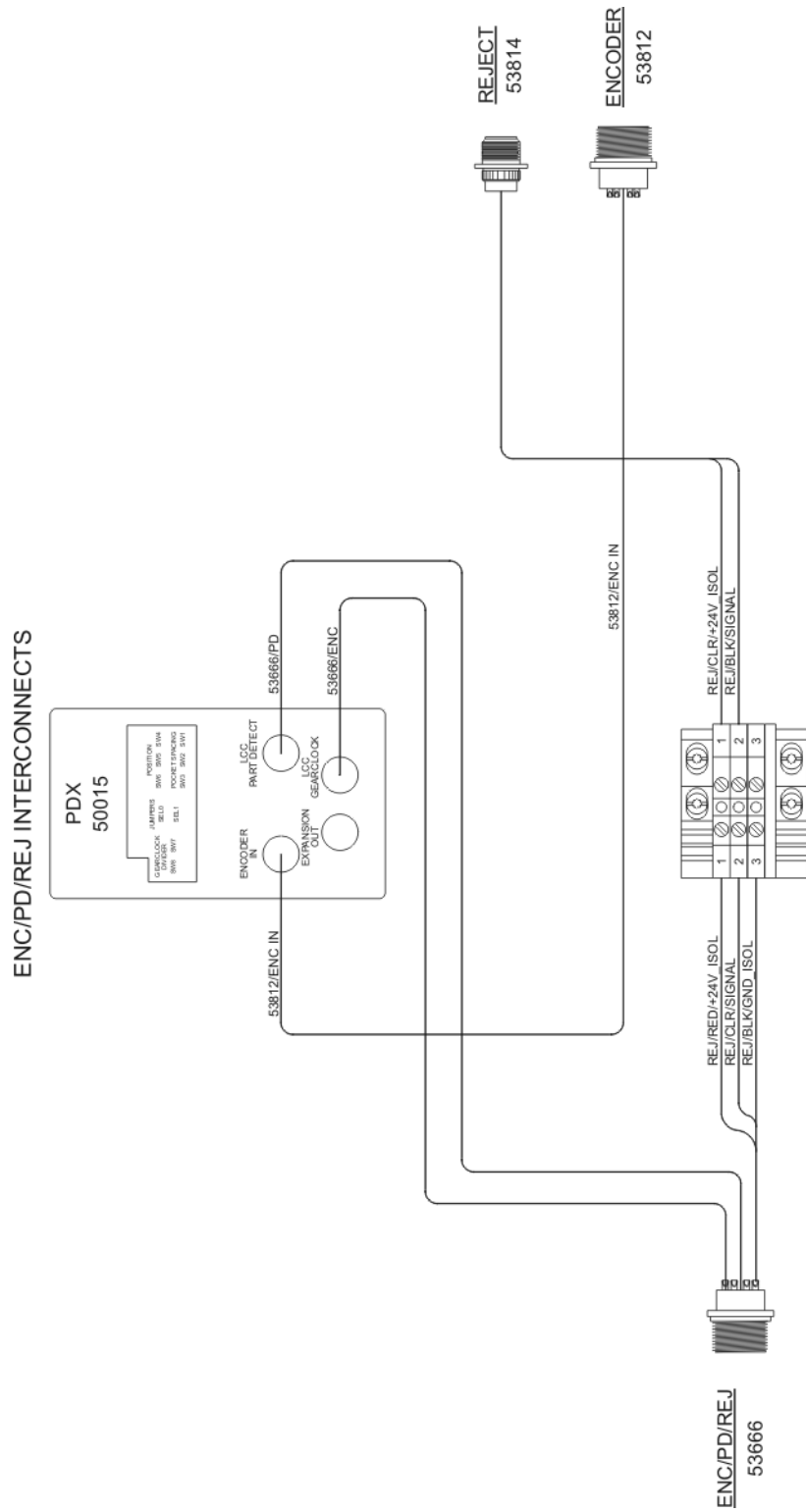

Cabinet to electronic enclosure interconnect

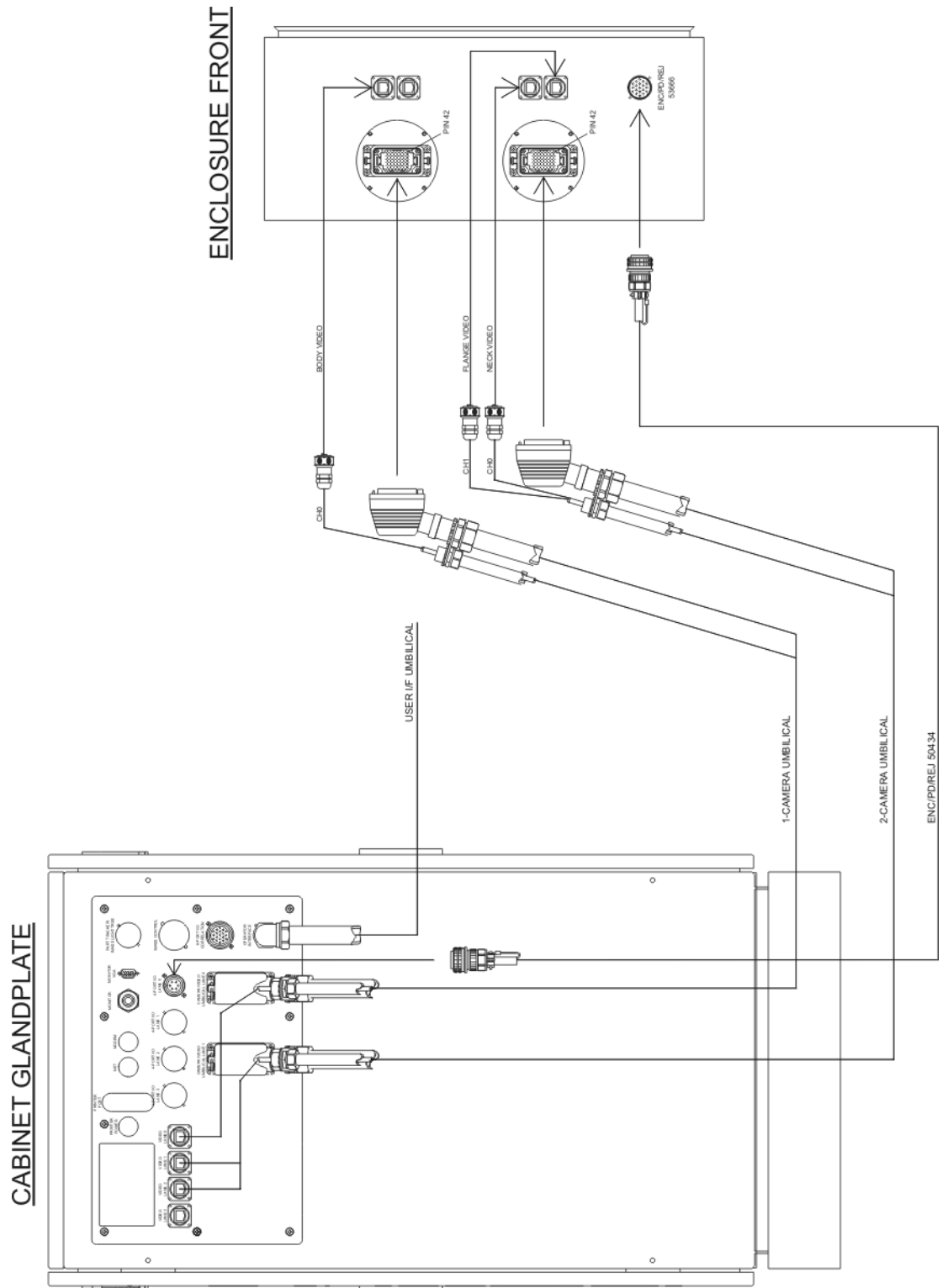

Electronic enclosure to Belvac gland plate interconnect

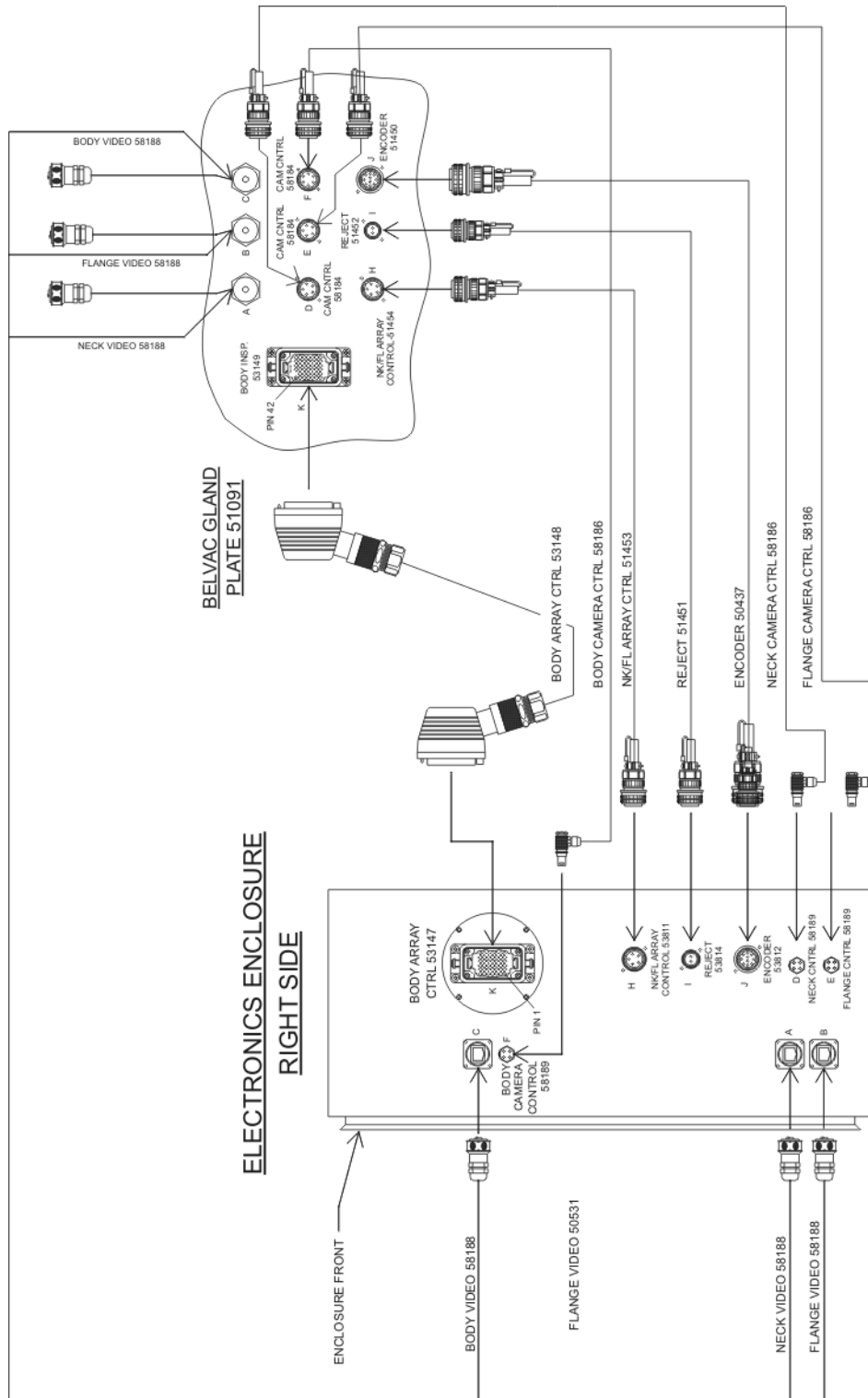

Belvac gland plate to camera module interconnect

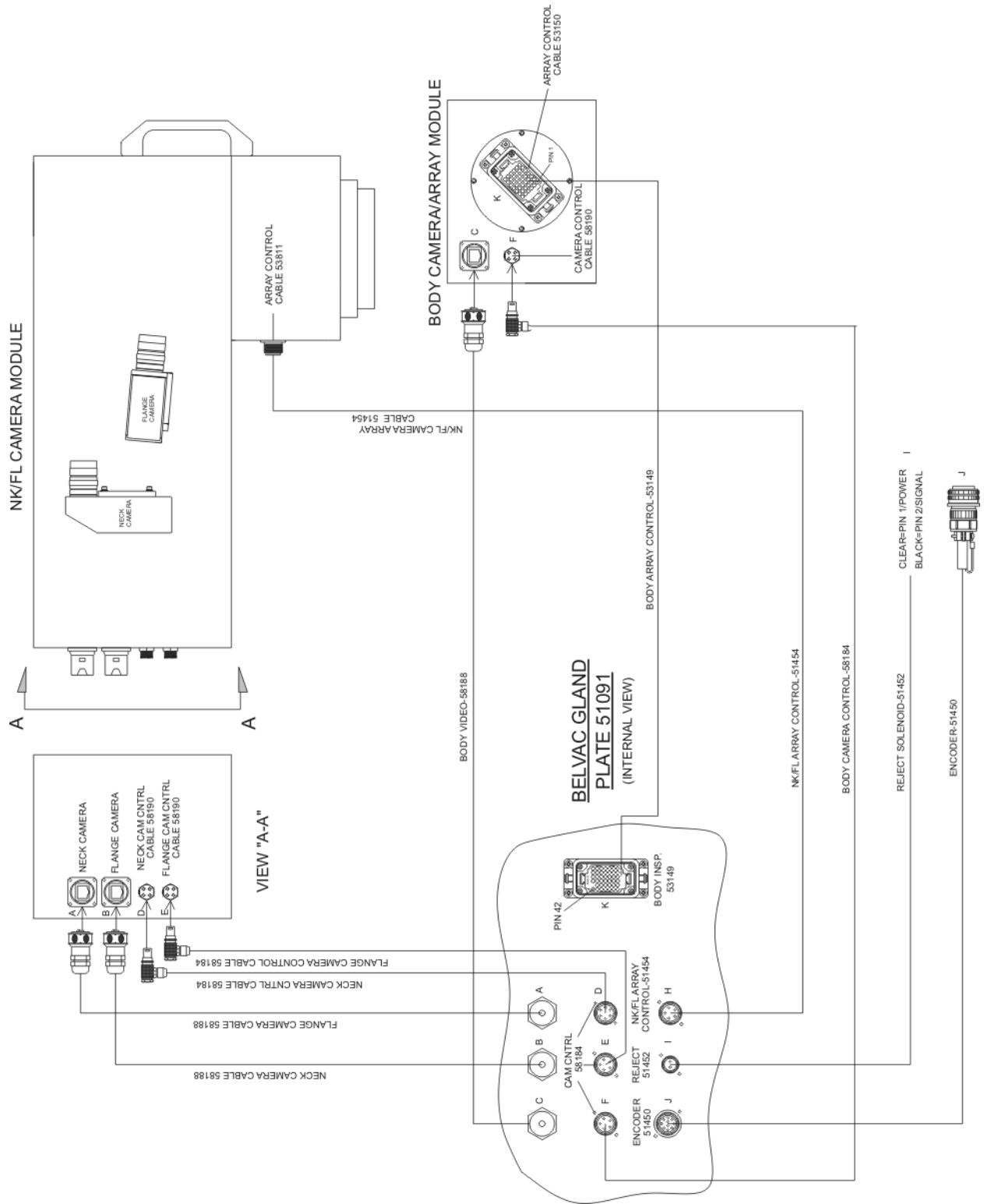

ADJUSTING THE CP4402 INSPECTION MODULE

The CP4402 inspection module is normally installed behind the turrets of the last modules in a Belvac machine. Occasionally, you will need to remove this module for repair, calibration, or maintenance.



Danger

Do not attempt to service the Inspection Module while the Belvac is running. Also, be sure that the E-stop button on the Belvac system is pressed before servicing Inspection Module. Contact with moving machinery could result in serious injury.

Removing CP4402 from Belvac

Module should be removed for adjustments. You will need the calibration cart on which to install the inspection module after removing it from the Belvac machine. Make sure you have the correct installation plate for CP4402 installed on calibration cart.

To remove the CP4402 module:

1. Ensure the Belvac is in Emergency Stop condition.
2. Switch off Intellispec power by turning the switch on the side of cabinet.
3. Disconnect the camera and array cables from the inspection module.
4. Remove the array assembly by disconnecting the clamps. Set aside.
5. Remove the inspection module by disconnecting the clamps.
6. Install the inspection module on calibration cart (shown below), securing the clamps. Connect the array assembly to the inspection module and secure the clamps.
7. Position the calibration cart near the Intellispec so that you can see the screen while making adjustments on the inspection module.
8. Disconnect the cables at the side of the Belvac, and connect them to the inspection module.

9. Switch on Intellispec system to perform adjustments.

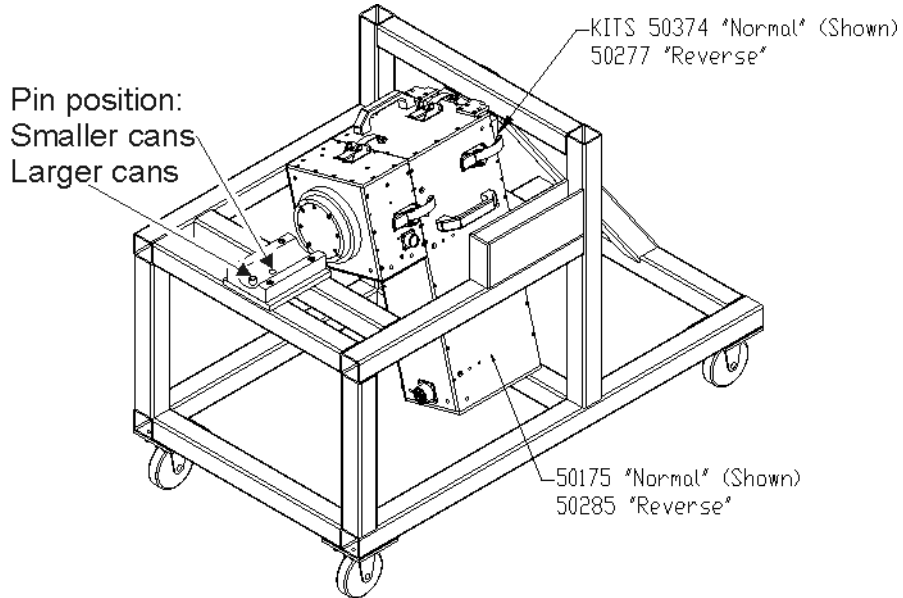

To replace module, refer to *Installing CP4402 into Belvac* (on page 139).

CP4402 components

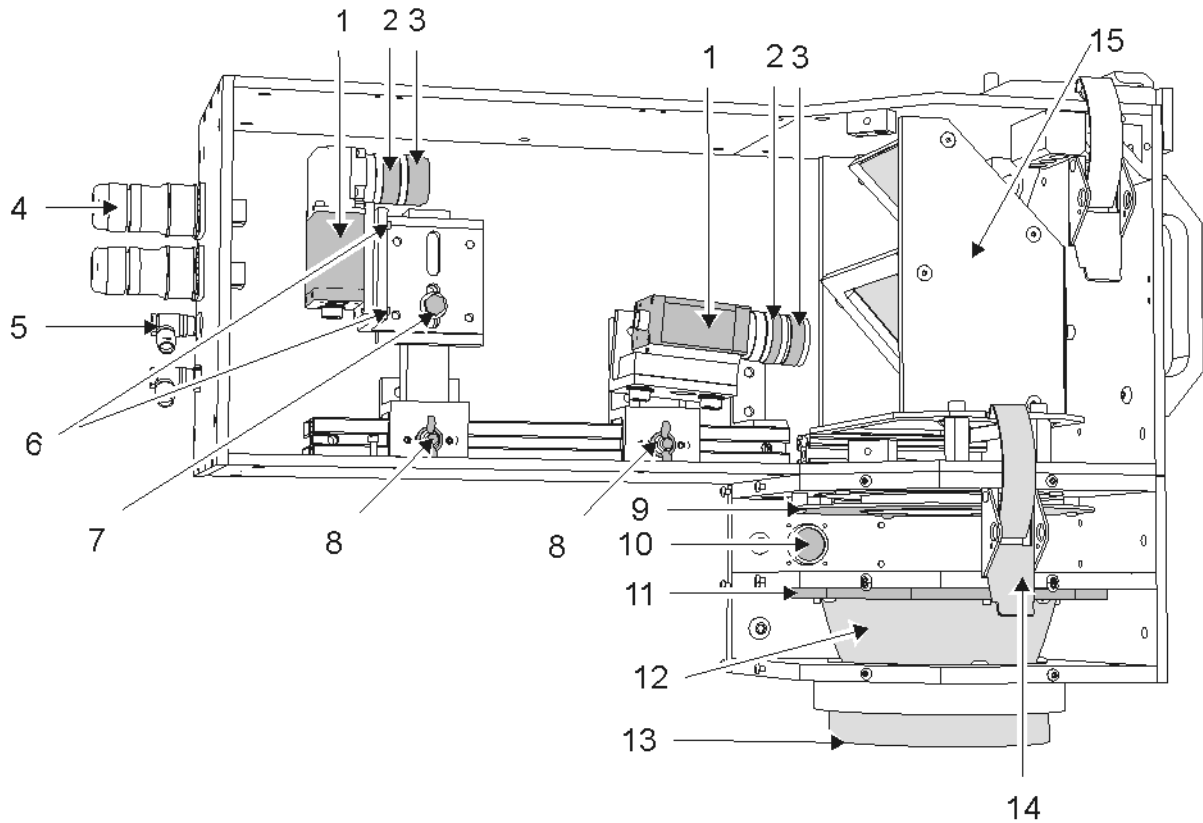

1	Camera
2	Focus adjustment
3	Aperture adjustment
4	Video connectors
5	Camera control cable
6	Z axis adjustment
7	Y axis- vertical adjustment
8	X axis - horizontal adjustment
9	Top array and diffuser
10	Array power connector
11	Bottom array
12	Ellipsoidal mirror
13	Plastic shield on bottom - 4 flathead screws for removal
14	Clamp to remove array assembly for installation/ removal from Belvac
15	Mirror/ beam splitter assembly

Observe Part Image

When adjusting the focus, aperture, or height, it is helpful to place the Intellispec System in the Live Image mode so you can immediately see the effect of an adjustment on the image quality.

With the system Offline, choose the correct channel, right-click the Snap button, and choose  Live Images. Place a part against the pin on the calibration cart. The pin on the cart should be in the forward position for 33cl cans, and in the rear position for 50cl cans.

Camera Adjustments

Focus Adjustments

To adjust focus, carefully remove or open the inspection module cover. Turn the focus adjust ring while observing the part image on the monitor. Adjust the focus for the sharpest image. If needed, adjust the ***aperture*** (see "Aperture Adjustment" on page 124), then reinstall the cover.

Camera Position Adjustment

❖ *Note: Normally, you do not need to adjust camera position. Adjust only if you are initially installing, or have replaced the inspection module.*

The cameras can be adjusted for image size and position. Carefully remove the side panel cover of the inspection module. Adjust cameras as necessary while observing image on Intellispec monitor. After making all camera adjustments, replace module cover.

Lighting Adjustments

Aperture Adjustment

The aperture controls the amount of light that passes through the lens. The programmable light source provides the range of light intensity required for most applications. However, you can manually adjust the aperture if necessary by turning the aperture adjust ring on the camera lens.

Adjust Lighting Through Software

Using SmartLight in the software, adjust the lighting to optimize the contrast of the defects. Also refer to ***lighting setup tips*** (on page 113).

❖ *Note: After adjusting lighting, you may have to re-adjust the camera focus and/or aperture. It may take some back and forth adjustment between lighting and focus to achieve an optimal image.*

Maintenance

Refer to maintenance procedures, with attention to the following sections:

Clean the following surfaces as often as indicated in the ***table*** (see "Maintenance Frequency" on page 87) :

- ***Glass surfaces*** (see "Cleaning Glass Surfaces" on page 88)
 - ***Camera lens*** (see "Cleaning the Camera Lens" on page 89)
 - ***Beam splitter*** (see "Cleaning the Beam Splitter" on page 89)
- ***Plastic surfaces*** (see "Cleaning Plastic Surfaces" on page 92)
 - ***Plastic shield*** (see "Modules with Plastic Shields" on page 95)
- ***Ellipsoidal mirror*** (see "Cleaning the Ellipsoidal Mirror" on page 94) (if applicable)
- ***Part detector*** (see "Cleaning the Part Detector" on page 95)
- Cabinet and pc ***air filters*** (see "Processor Cabinet Air Filter Maintenance" on page 98)

Installing CP4402 into Belvac

After performing maintenance or repairs, the inspection module must be installed into Belvac machine.

1. Ensure the Belvac is in Emergency Stop condition.
2. Switch off Intellispec by turning the switch on the side of the cabinet.
3. Remove cables from inspection module and re-connect them to the side of the Belvac.
4. Remove the array assembly from the inspection module by disconnecting the clamps. Set aside.
5. Hold the inspection module, disconnect the clamps, and remove the inspection module from the calibration cart.

- Carefully lift inspection module over turrets in Belvac machine. Install inspection module (B section) on its mounting plate and secure the clamps. Install array (A section) assembly on inspection module and secure the clamps. See illustration page .
- Attach the camera and array cables to the inspection module.

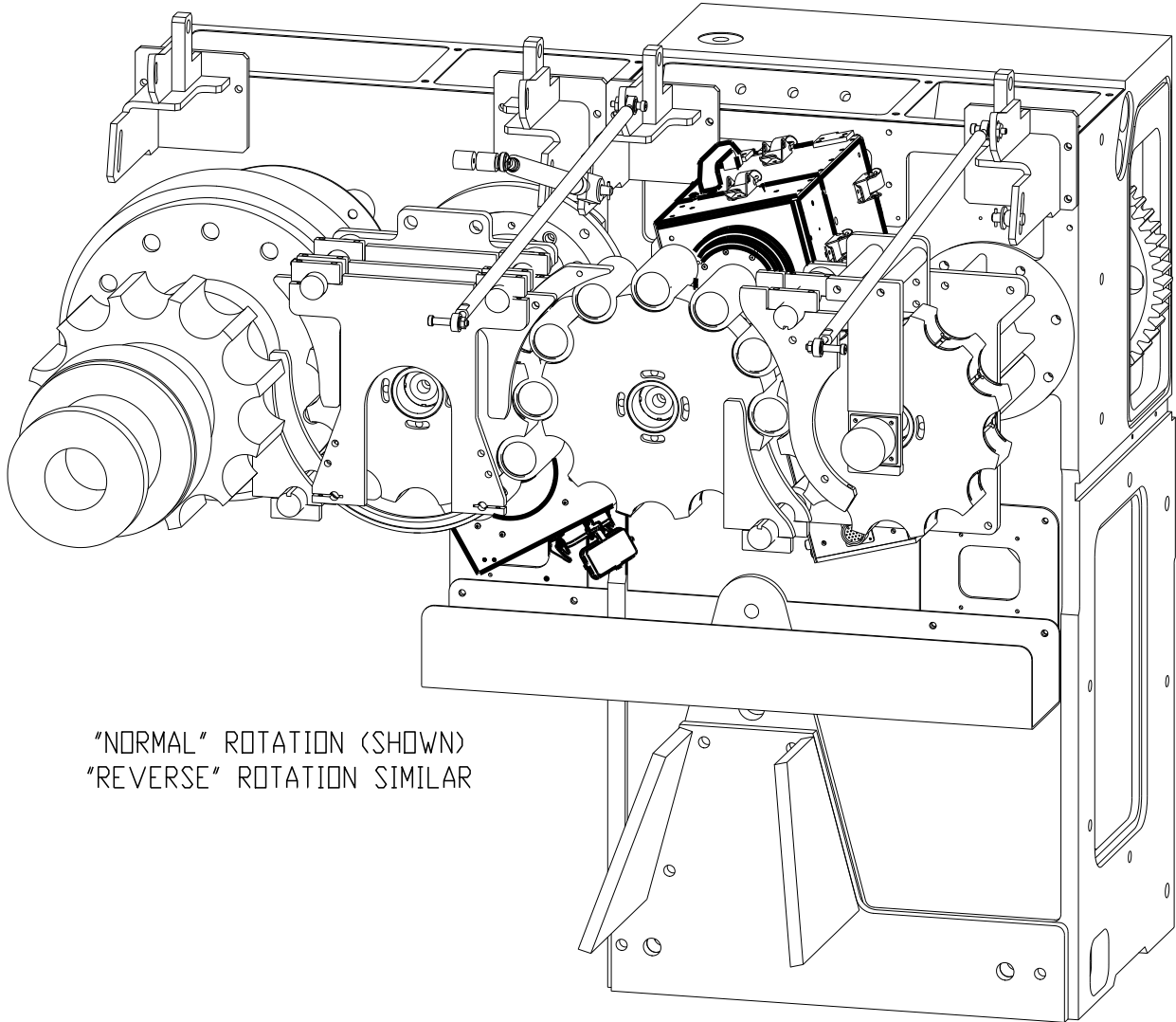

"NORMAL" ROTATION (SHOWN)
"REVERSE" ROTATION SIMILAR

You are now ready to use this inspection module. While the power is still off, you may disconnect the cables for the other inspection module and perform its maintenance. Or, you may wish to resume normal operation. Switch on Intellispec power.

ADJUSTING THE CP4410 MODULE

The CP4410 inspection module is normally installed behind the turrets of the last modules in a Belvac machine. Occasionally, you will need to remove this module for repair, calibration, or maintenance.



Danger

Do not attempt to service the Inspection Module while the Belvac is running. Also, be sure that the E-stop button on the Belvac system is pressed before servicing Inspection Module. Contact with moving machinery could result in serious injury.

Removing CP4410 from Belvac

Module should be removed for adjustments. You will need the calibration cart on which to install the inspection module after removing it from the Belvac machine.

1. Ensure the Belvac is in Emergency Stop condition
2. Save sample images on Intellispec if necessary. Save job. Switch off Intellispec power by turning the switch on the side of cabinet.
3. Disconnect the camera and array cables from the inspection module.
4. Hold the inspection module and remove it by pulling release pins.
5. Install the inspection module on calibration cart, matching notches on mounting plates and securing the release pins.
6. Position the calibration cart near the Intellispec so that you can see the screen while making adjustments on the inspection module.
7. Remove the camera and array cables from the side of the Belvac, and connect to inspection module.
8. Switch on Intellispec system to perform adjustments.

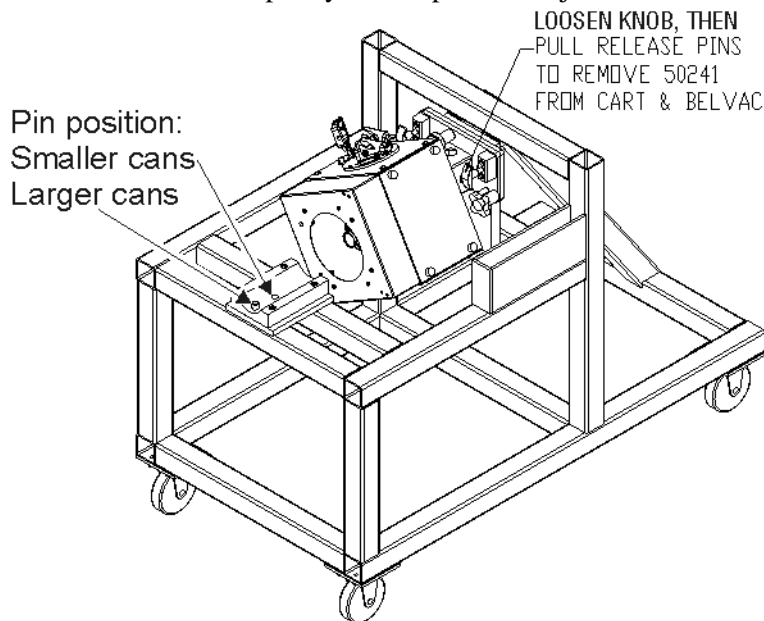

CP4410 Components

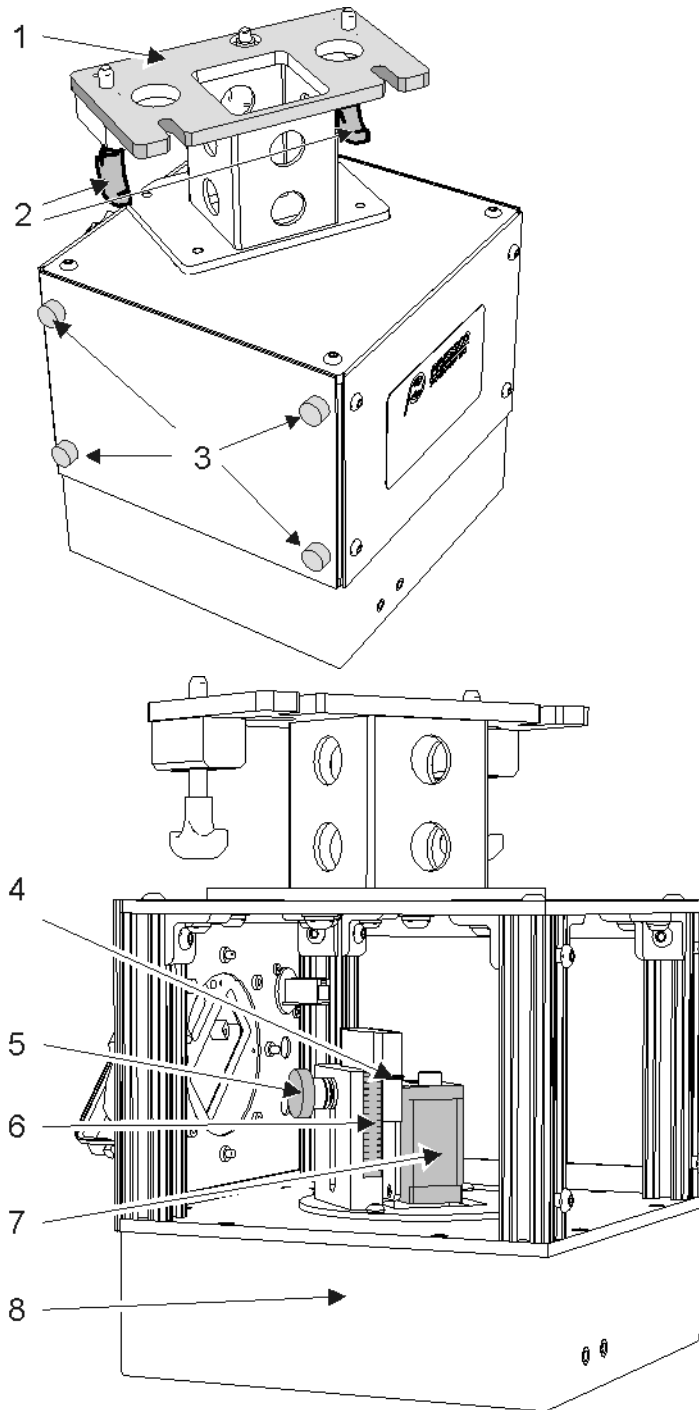

1	Belvac mounting plate for mounting inside Belvac or on calibration cart
2	Handles - pull to release module
3	Thumbscrews for removal of cover plate
4	Height reference mark

5	Height adjustment knob
6	Height reference ruler
7	Camera
8	Focus and aperture adjusted from underside of module

Observe Part Image

When adjusting the focus, aperture, or height, it is helpful to place the Intellispec System in the Live Image mode so you can immediately see the effect of an adjustment on the image quality.

With the system Offline, choose the correct channel, right-click the Snap button, and choose  Live Images. Place a part against the pin on the calibration cart. The pin on the cart should be in the forward position for 33cl cans, and in the rear position for 50cl cans.

Camera Adjustments

Focus Adjustments

The focus and aperture adjust rings are located on the camera lens, and are accessible from the underside of the module.

To adjust focus, turn the focus adjust ring on the camera lens while observing the image on the monitor. Adjust focus for the sharpest image.

Camera Height Adjustment

❖ *Note: Normally, you do not need to adjust camera height. Adjust only if you are initially installing, or have replaced the inspection module.*

The height of the camera affects the size of the part image. Adjust the camera height by loosening the height adjust knob and moving the camera up or down. Make note of the position of the reference mark with respect to the height reference ruler before removing camera or adjusting height.

Lighting Adjustments

Aperture Adjustment

The aperture controls the amount of light that passes through the lens. The programmable light source provides the range of light intensity required for most applications. However, you can manually adjust the aperture if necessary by turning the aperture adjust ring on the camera lens.

Adjust Lighting Through Software

Using SmartLight in the software, adjust the lighting to optimize the contrast of the defects. Also refer to *lighting setup tips* (on page 113).

❖ *Note: After adjusting lighting, you may have to re-adjust the camera focus and/ or aperture. It may take some back and forth adjustment between lighting and focus to achieve an optimal image.*

Maintenance

Refer to maintenance procedures, with attention to the following sections:

Clean the following surfaces as often as indicated in the **table** (see "Maintenance Frequency" on page 87) :

- **Glass surfaces** (see "Cleaning Glass Surfaces" on page 88)
 - **Camera lens** (see "Cleaning the Camera Lens" on page 89)
- **Plastic surfaces** (see "Cleaning Plastic Surfaces" on page 92)
 - Light diffuser
- **Part detector** (see "Cleaning the Part Detector" on page 95)
- Cabinet and pc **air filters** (see "Processor Cabinet Air Filter Maintenance" on page 98)

Installing CP4410 into Belvac

After performing maintenance or repairs, the inspection module must be installed into Belvac machine.

1. Ensure the Belvac is in Emergency Stop condition.
2. Switch off Intellispec by turning the switch on the side of the cabinet.
3. Remove camera and array cables from inspection module and re-connect to the side of the Belvac.
4. Hold inspection module, loosen knob, and pull release pins to remove from calibration cart.
5. Carefully install inspection module on its mounting plate in the Belvac machine and secure the knobs. See illustration below.

6. Attach camera and array cables to inspection module.

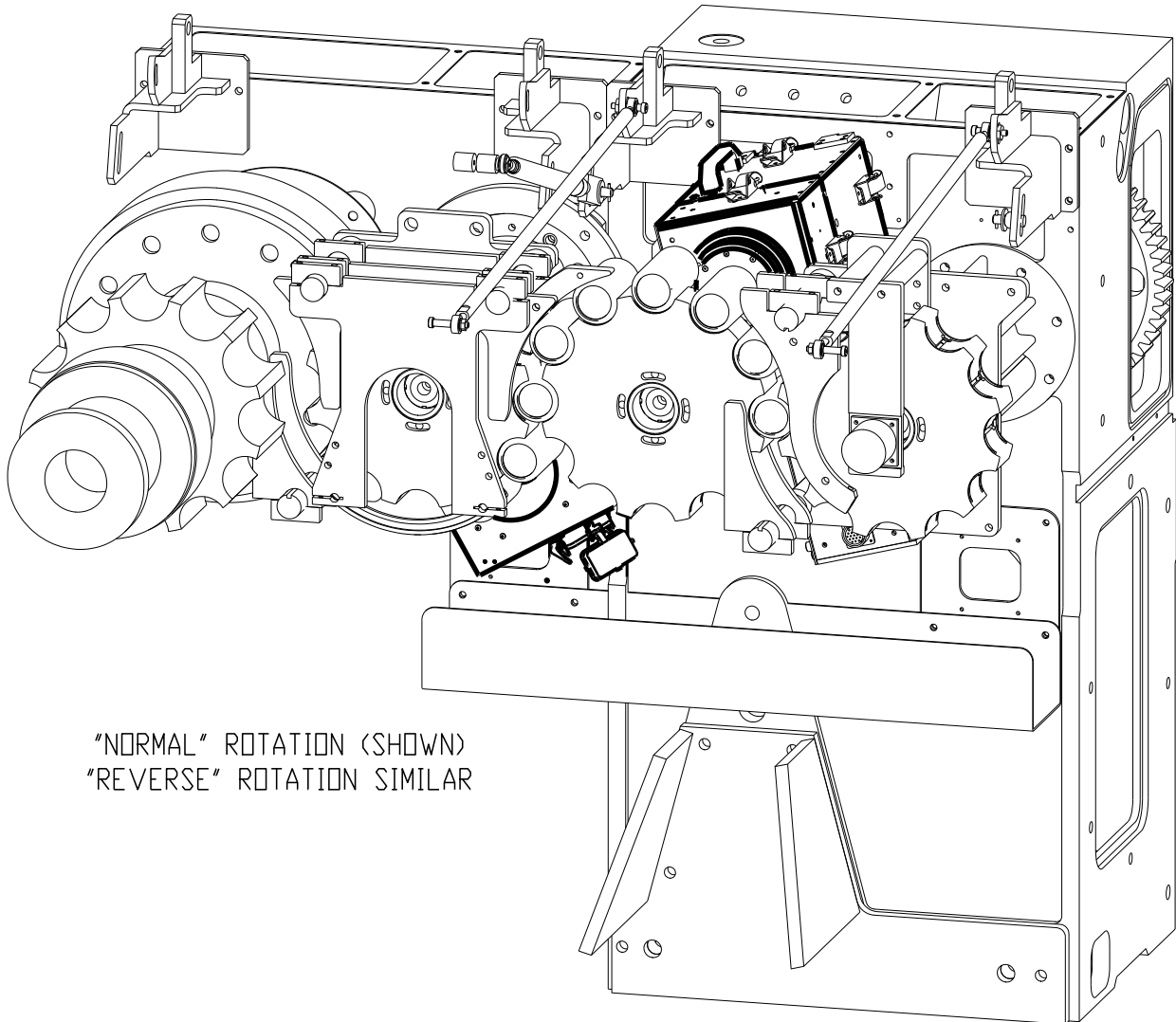

"NORMAL" ROTATION (SHOWN)
"REVERSE" ROTATION SIMILAR

You are now ready to use this inspection module. While the power is still off, you may disconnect the cables for the other inspection module and perform its maintenance. Or, you may wish to resume normal operation. Switch on Intellispec power.

REJECT SETTINGS

Refer to the Intellispec Programming Guide (for 3.1 and later software) for information about Adaptive Reject, which is used in Belvac applications.

Chapter 13

CP4402E, CP4410E MODULES

DESCRIPTION

These modules are designed to inspect the inside of beverage cans. The CP4410E uses one camera to inspect the sidewall and dome (body) of a can. It can be used alone or in conjunction with a CP4402E.

The CP4402E uses two cameras and special mirrors to inspect the neck and flange of beverage cans. The images from these two cameras are multiplexed into one part image. The CP4402E must be used in conjunction with a CP4410E module – the CP4402E is not a standalone module. When mounted on a vertical conveyor, the CP4402E is mounted on the bottom due to its size and weight as compared to the CP4410E. It helps support the weight of the CP4410E.



CP4402E/ CP4410E components

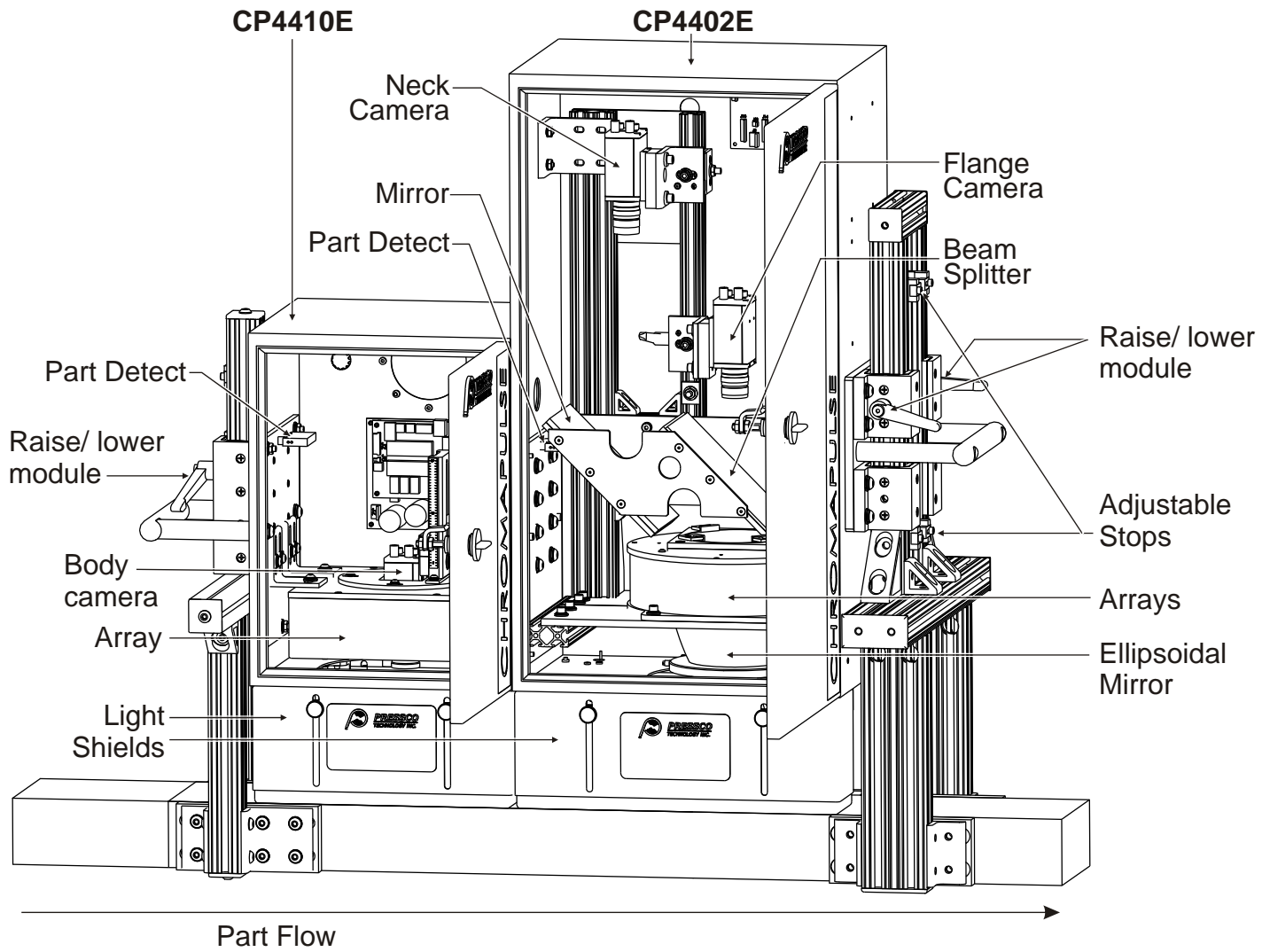

Lighting Zones: CP4402E, CP4410E

The illustrations below show the lighting zone grouping for the CP4402E and CP4410E inspection modules. These also apply to CP4402 and CP4410 inspection modules.

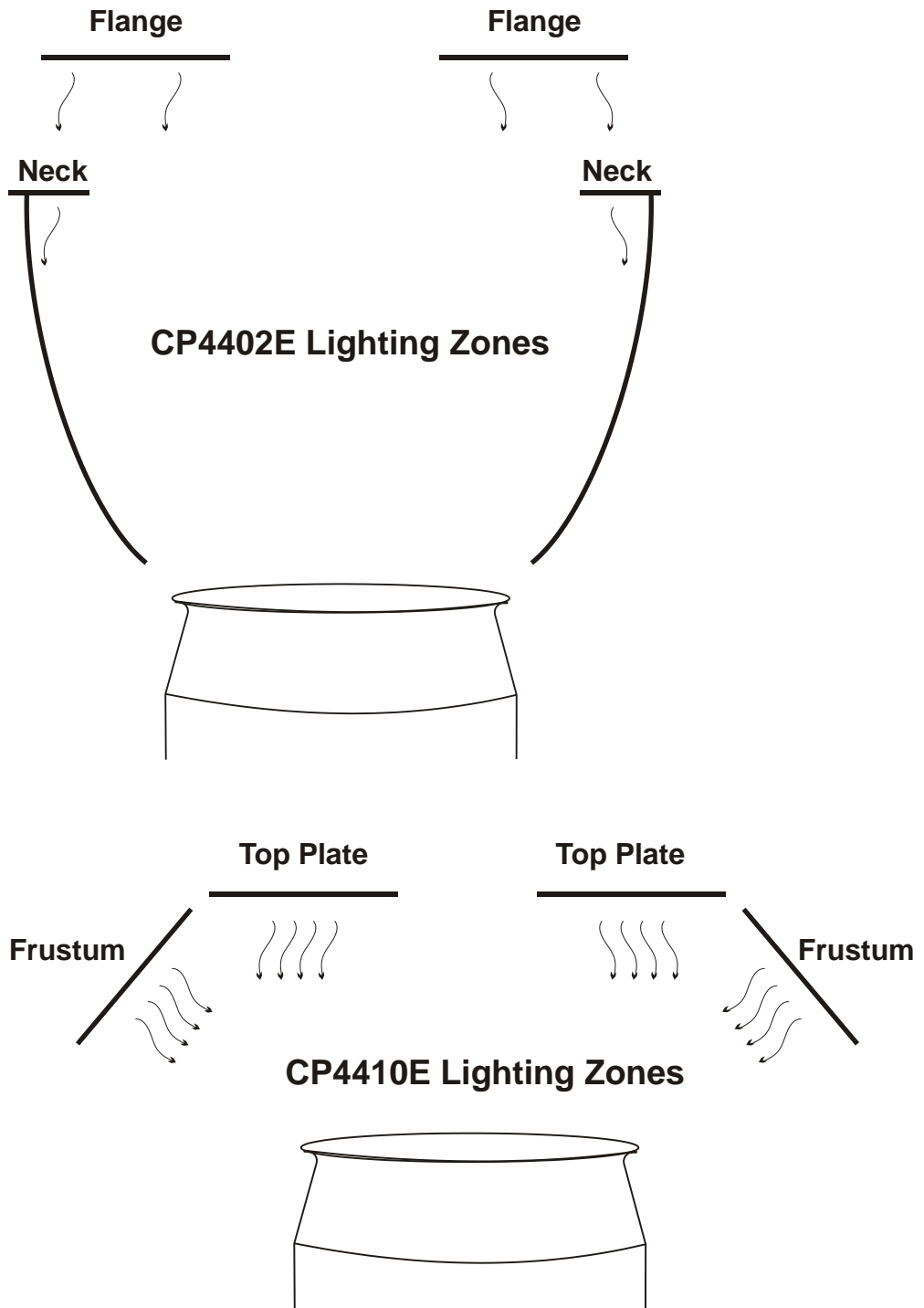

The table below shows the zone grouping for the CP4402E and CP4410E inspection modules. The intensity of each zone group is adjustable through SmartLight software.

The color of the arrays and filters on the cameras dictate what color the camera sees. In the CP4402E, the Neck camera sees only red light. The Flange camera sees only blue light.

❖ *Note: These zones are programmed at Pressco and should not be changed. You may view the setup in Lighting Control >> Setup >> Array Configuration.*

Part material type	Top plate (upper array type)	Frustum (lower array type)	Flange (ring array type)	Neck (ring array type)
Steel	8 red zones	8 red zones	2 zones: ▪ 1 red zone ▪ 1 blue zone	1 red zone
Either steel or aluminum	8 white zones	8 white zones	2 zones: ▪ 1 red zone ▪ 1 blue zone	1 red zone
Aluminum	8 blue zones	8 blue zones	2 zones: ▪ 1 red zone ▪ 1 blue zone	1 red zone

SYSTEM LEVEL INTERCONNECT CP4402E/ CP4410E

Interconnect diagram for Intellispec Series IV - CP4402E/ CP4410E inspection modules

Not all systems have Light Tree. In these cases, keyboard hooks up directly to cabinet - not through umbilical.

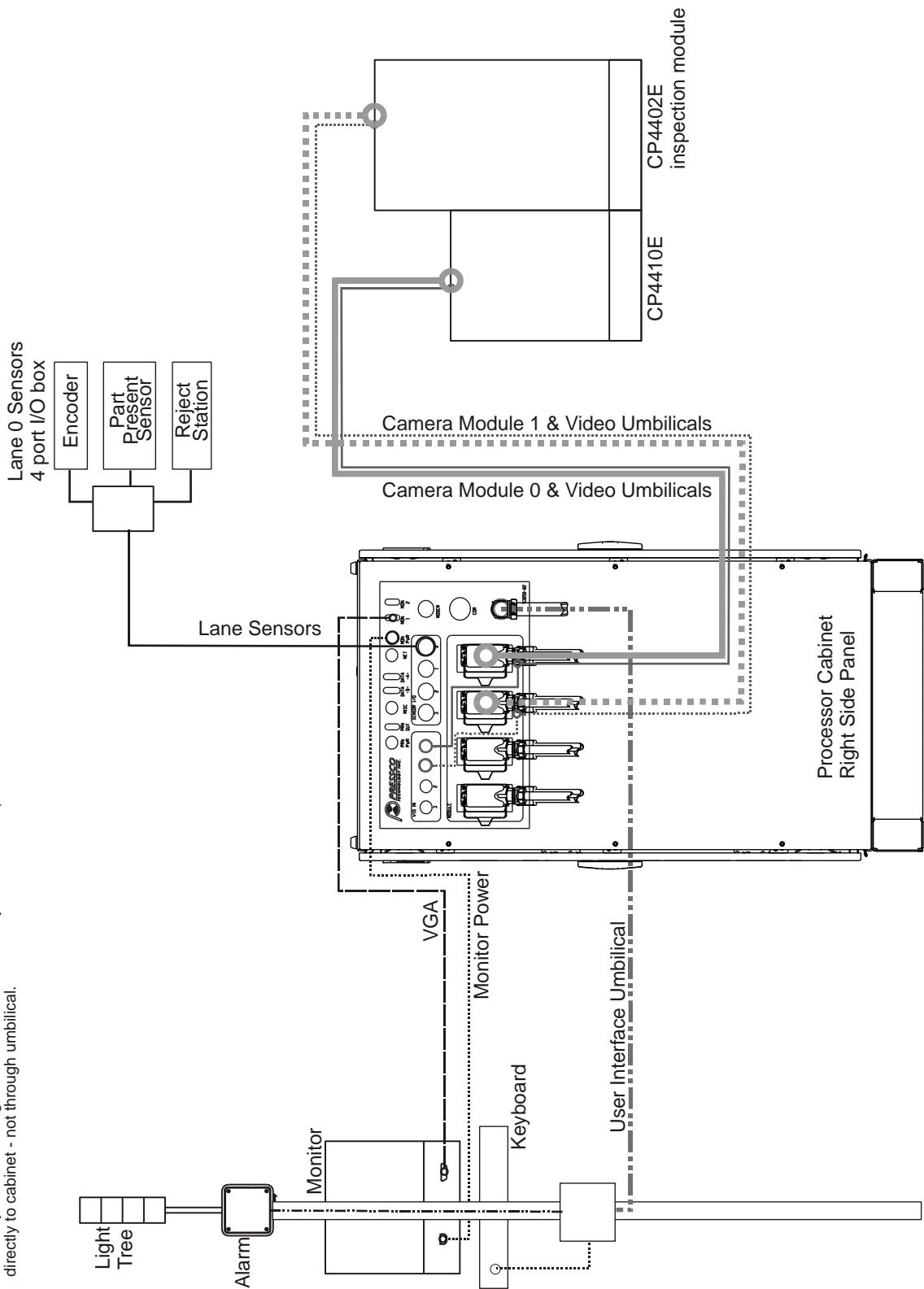

ADJUSTING THE CP4402E AND CP4410E INSPECTION MODULES

This section covers camera adjustments that may be required to keep the inspection modules working properly. Adjustments include the camera position, aperture, and camera focus.

The focus adjustment controls the clarity of the image; the aperture adjustment controls the amount of light admitted by the shutter. Normally the inspection modules do not require further adjustment after initial system setup. Circumstances that might require additional adjustments are camera replacement, strobe replacement, or a substantial change in part size or color.

DANGER

The inspection modules are mounted near moving machinery. Use extreme caution to avoid contact with moving machinery when servicing inspection modules as serious personal injury could result. Ensure machinery is in an emergency stop state before servicing inspection modules.

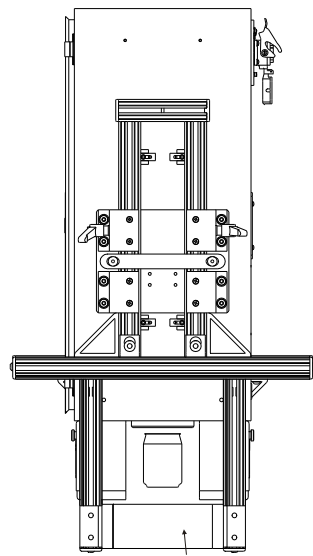

Center CP4402E tunnel over conveyor (or part).

Then adjust this screw if necessary to center CP4410E over part.

CP4402E camera adjustments

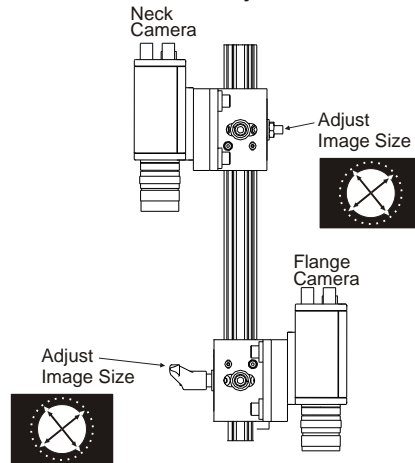

CP4410E camera adjustments

- Adjust Image Size
- Note position of camera on scale
- Loosen thumbscrew



Additional camera position adjustments



Adjust tunnel up & down (move at same time as CP4402E tunnel)

Then adjust light shields for both tunnels

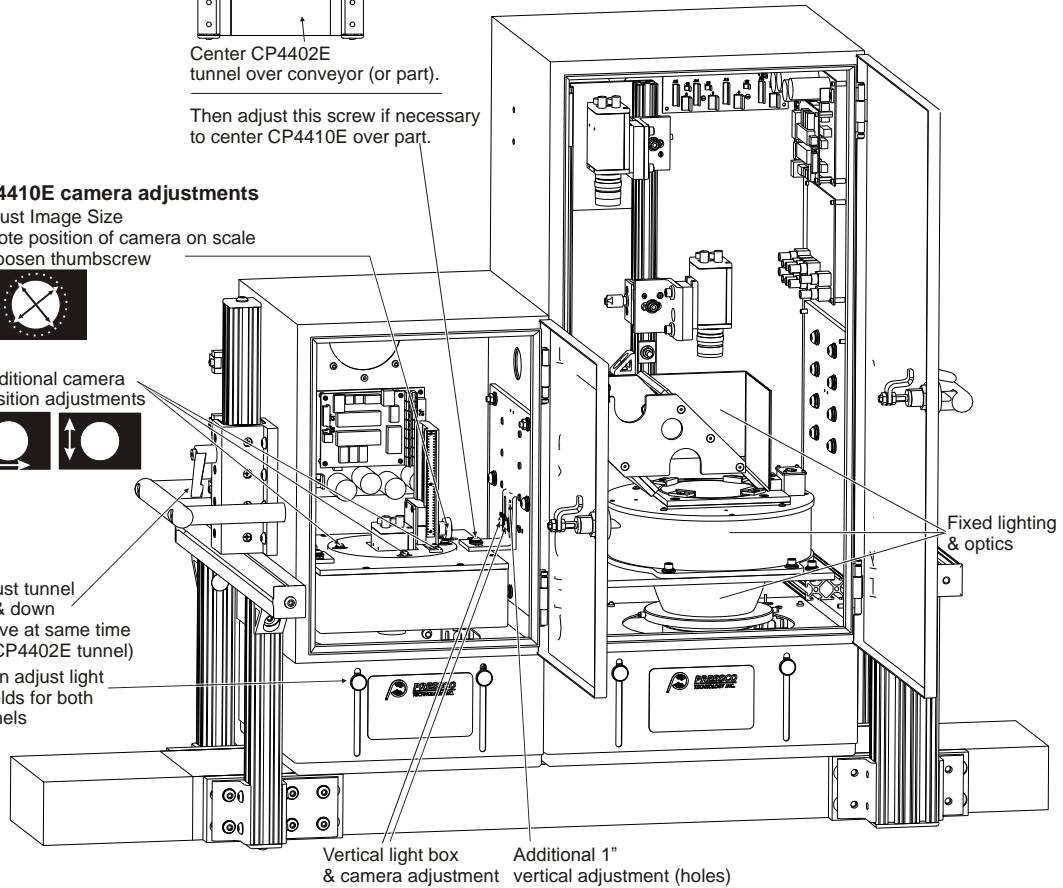

Observe Part Image

When adjusting the focus, aperture, or height, it is helpful to place the Intellispec System in the Live Image mode so you can immediately see the effect of an adjustment on the image quality.

With the system Offline, choose the correct camera view > right-click the Snap button > and choose  Live Images. If the production line is not running, place a part in the camera view as it would be during normal production.

Camera Adjustments

Focus Adjustments

To adjust focus, carefully remove the inspection module cover. Turn the focus adjust ring while observing the part image on the monitor. Adjust the focus for the sharpest image.

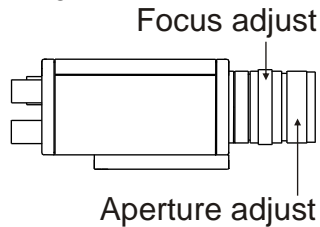

The focus and aperture adjustments are accessible from under the camera & lighting box of the CP4410E, and at the cameras on the CP4402E.

If needed, make other adjustments as described below, then reinstall the cover.

Camera Position Adjustment

❖ *Note: Normally, you do not need to adjust camera position. Adjust only if you are initially installing, or have replaced the inspection module.*

Adjust cameras as necessary while observing image on Intellispec monitor. After making all camera and lighting adjustments, replace module cover. Refer to the **adjustment** (see "Adjusting the CP4402E and CP4410E Inspection Modules" on page 152) diagram.

BODY CAMERA (CP4410E)

First make a note of original camera position on scale. Loosen the thumbscrew to move the camera up or down to change the size of the image. The thumbscrew can also be loosened to remove camera if replacement becomes necessary.

NECK CAMERA (CP4402E)

Loosen the screw on the post that is on the opposite side of the camera. Move the camera up or down to adjust the size of the part in the image. Tighten screw.

FLANGE CAMERA

Loosen the lever near the flange camera. Move up or down to adjust the size of the part in the image.

Lighting Adjustments

Aperture Adjustment

The aperture controls the amount of light that passes through the lens. The programmable light source provides the range of light intensity required for most applications. However, you can manually adjust the aperture if necessary by turning the aperture adjust ring on the camera lens. Reinstall the cover.

Adjust Lighting Through Software

Using SmartLight in the software, adjust the lighting to optimize the contrast of the defects. Also refer to *lighting setup tips* (on page 113).

- ❖ *Note: After adjusting lighting, you may have to re-adjust the camera focus and/ or aperture. It may take some back and forth adjustment between lighting and focus to achieve an optimal image.*
-

MAINTENANCE

Refer to maintenance procedures, with attention to the following sections:

Clean the following surfaces as often as indicated in the *table* (see "Maintenance Frequency" on page 87) :

- **Glass surfaces** (see "Cleaning Glass Surfaces" on page 88)
 - **Camera lens** (see "Cleaning the Camera Lens" on page 89)
 - **Beam splitter** (see "Cleaning the Beam Splitter" on page 89)
- **Plastic surfaces** (see "Cleaning Plastic Surfaces" on page 92)
 - **Plastic shield** (see "Modules with Plastic Shields" on page 95)
- **Ellipsoidal mirror** (see "Cleaning the Ellipsoidal Mirror" on page 94) (if applicable)
- **Part detector** (see "Cleaning the Part Detector" on page 95)
- Cabinet and pc **air filters** (see "Processor Cabinet Air Filter Maintenance" on page 98)

Chapter 14

CP4411E, CP4412E MODULES

DESCRIPTION

The CP4411E and CP4412E are designed to inspect the inside of beverage cans. These two model numbers use the same outside housing. The CP4411E contains two cameras, whereas the CP4412E contains three cameras.

The **CP4411E** inspects the Neck of a can with one camera, and the Sidewall/ Dome (Body) of a can with the other camera.

The **CP4412E** inspects the Neck and Flange of a can with two cameras multiplexed into one image. It inspects the Sidewall/ Dome (Body) of a can with the third camera.

Both of these modules use a special mirror to inspect the Neck area with one camera. The entire neck is viewable within one image, and the view angle is optimized for imaging pleats and other typical neck defects.



Lighting Zones: CP4411E, CP4412E

The illustrations below show the lighting zone grouping for the CP4411E and CP4412E inspection modules.

The tables below show the zone grouping for the CP4411E and CP4412E inspection modules. The intensity of each zone group is adjustable through SmartLight software. The color of the arrays and filters on the cameras dictates what color the camera sees. The Neck camera sees only red light. The Body camera sees only blue light. In the CP4412E, the Flange camera sees only green light.

❖ *Note: These zones are programmed at Pressco and should not be changed. You may view the setup in Lighting Control >> Setup >> Array Configuration.*

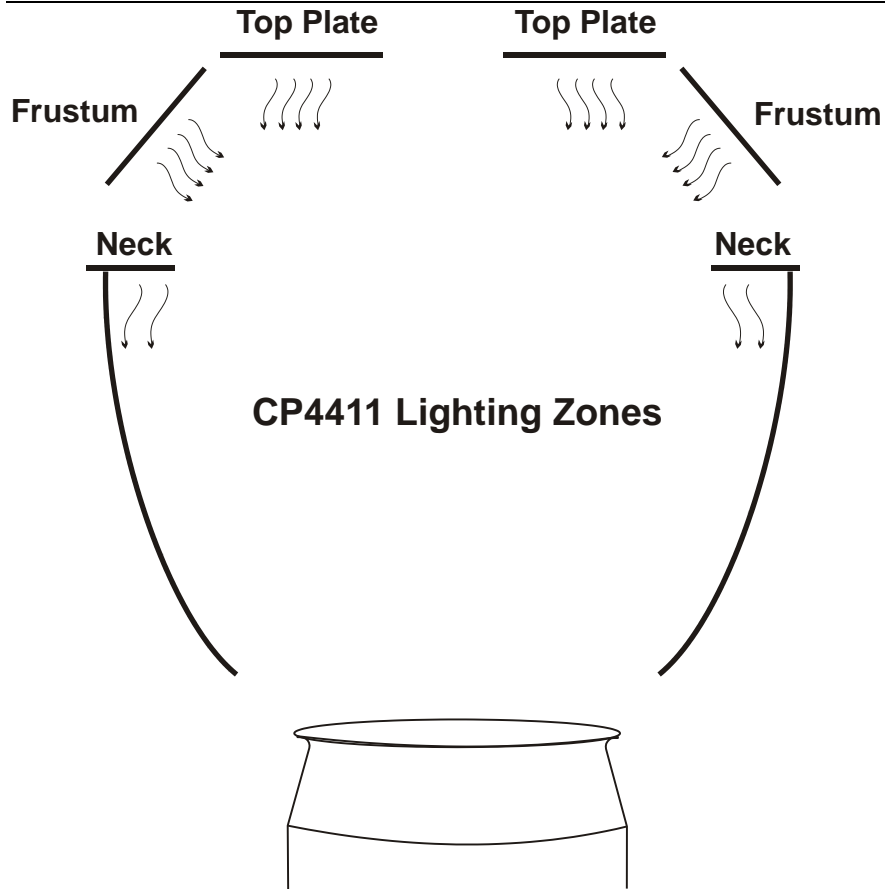

Top Plate (lower array type)	Frustum (upper array type)	Neck (ring array type)
5 blue zones	8 blue zones	2 red zones

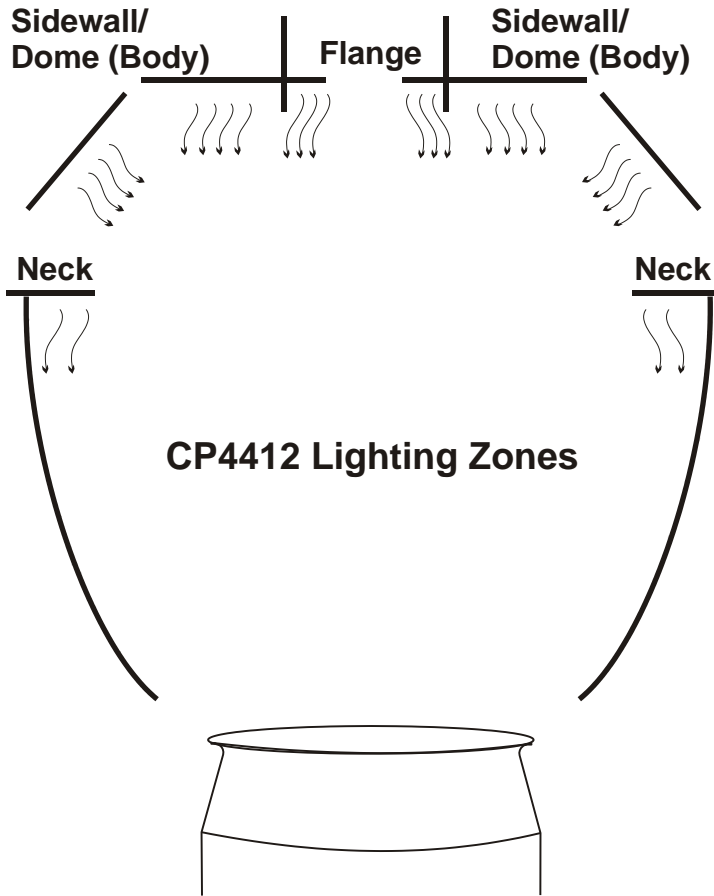

Body (upper array type)	Neck (lower array type)	Flange (ring array type)
10 blue zones	1 red zone	3 green zones

CP4411E/ CP4412E INTERCONNECT DIAGRAMS

System Level Interconnect CP4411E/ CP4412E Series IV

Interconnect diagram for Intellispec Series IV CP4411E/CP4412E inspection modules

Not all systems have Light Tree. In these cases, keyboard hooks up directly to cabinet - not through umbilical.

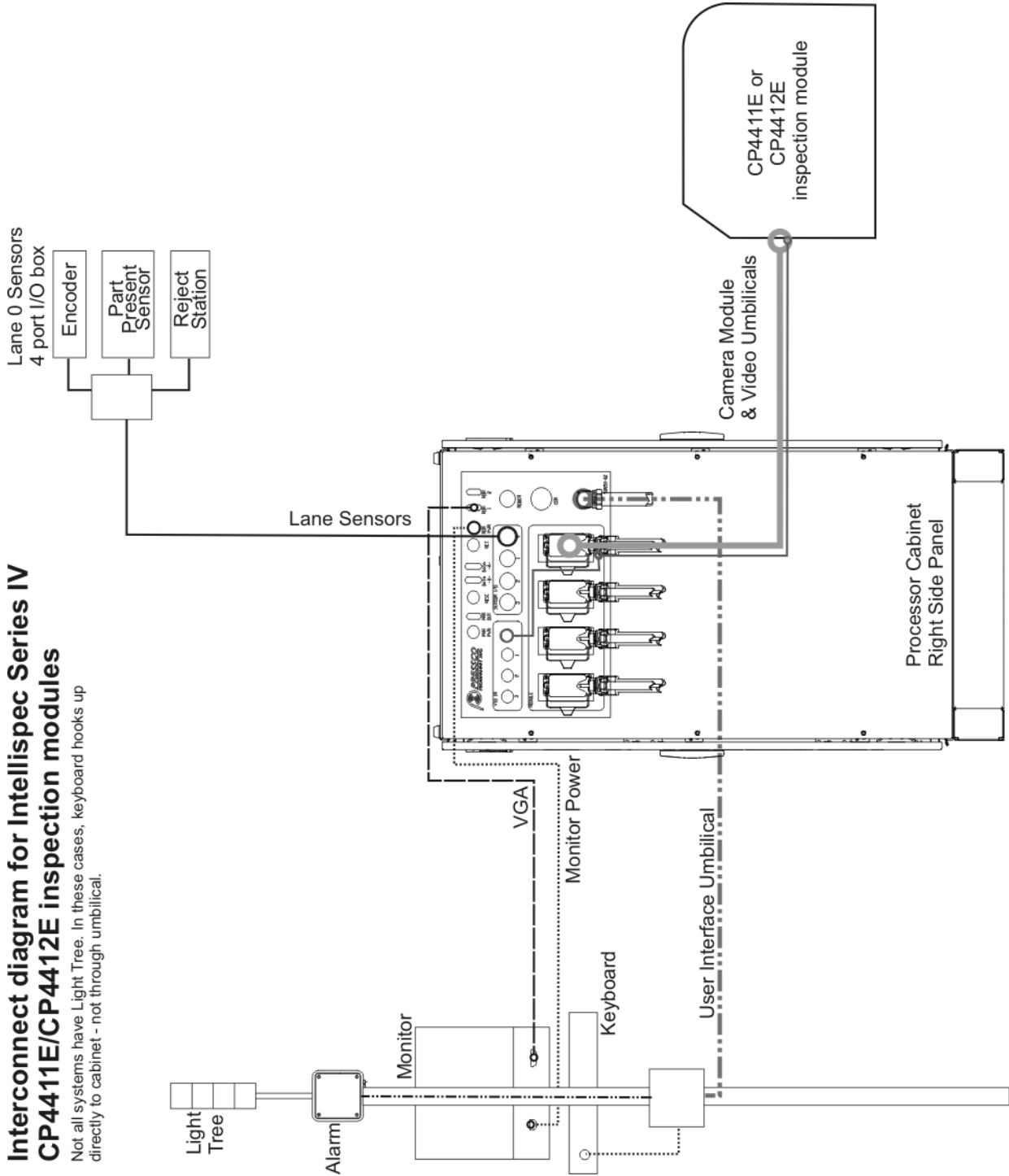

ADJUSTING THE CP4411E/ CP4412E INSPECTION MODULE

This section covers camera adjustments that may be required to keep the inspection modules working properly. Adjustments include the camera position, aperture, and camera focus.

The focus adjustment controls the clarity of the image; the aperture adjustment controls the amount of light admitted by the shutter. Normally the inspection modules do not require further adjustment after initial system setup. Circumstances that might require additional adjustments are camera replacement, strobe replacement, or a substantial change in part size or color.

DANGER

The inspection modules are mounted near moving machinery. Use extreme caution to avoid contact with moving machinery when servicing inspection modules as serious personal injury could result. Ensure machinery is in an emergency stop state before servicing inspection modules.

CP4411E, CP4412E Components

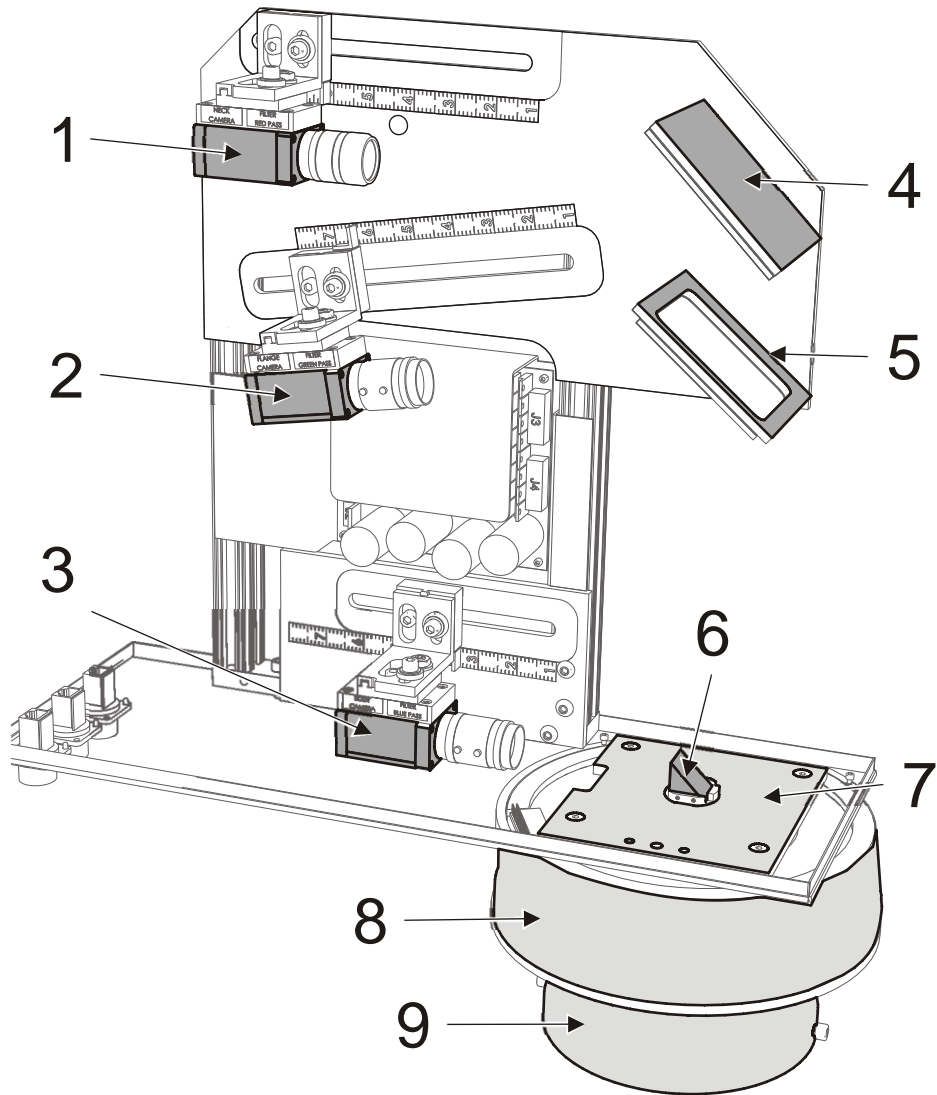

1	Neck camera with Red Pass filter installed
2	Flange camera with Green Pass filter installed (not present on CP4411E)
3	Body camera with Blue Pass filter installed
4	First surface mirror
5	Beam splitter
6	Periscope assembly for body camera
7	Window - neck and flange cameras look through
8	Body, Flange, and Neck arrays inside
9	Ellipsoidal mirror inside

Observe Part Image

When adjusting the focus, aperture, or height, it is helpful to place the Intellispec System in the Live Image mode so you can immediately see the effect of an adjustment on the image quality.

With the system Offline, choose the correct camera view > right-click the Snap button > and choose  Live Images. If the production line is not running, place a part in the camera view as it would be during normal production.

Camera Adjustments

Focus Adjustments

To adjust focus, carefully remove or open the inspection module cover. Turn the focus adjust ring while observing the part image on the monitor. Adjust the focus for the sharpest image. If needed, adjust the *aperture* (see "Aperture Adjustment" on page 124), then reinstall the cover.

Camera Position Adjustment

❖ *Note: Normally, you do not need to adjust camera position. Adjust only if you are initially installing, or have replaced the inspection module.*

The cameras can be adjusted along the X, Y, and Z axes. Adjust cameras as necessary while observing image on Intellispec monitor. After making all camera adjustments, replace module cover.

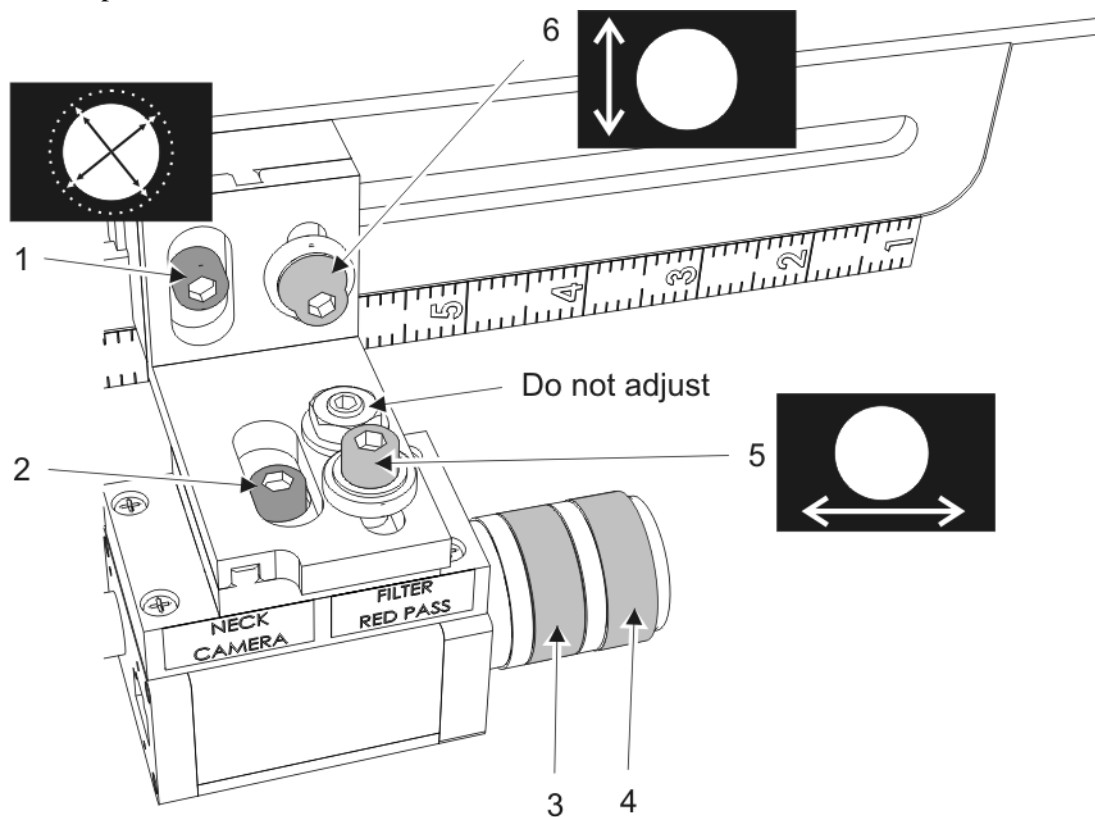

The recessed nuts, next to items 1 and 2, are used to attach the camera to the mounting plates.

1	Adjust to make size of part image larger or smaller
2	Loosen to remove camera for replacement
3	Focus adjust
4	Aperture adjust
5	X position adjust
6	Y position adjust

Lighting Adjustments

Aperture Adjustment

The aperture controls the amount of light that passes through the lens. The programmable light source provides the range of light intensity required for most applications. However, you can manually adjust the aperture if necessary by turning the aperture adjust ring on the camera lens. Reinstall the cover.

Adjust Lighting Through Software

Using SmartLight in the software, adjust the lighting to optimize the contrast of the defects. Also refer to *lighting setup tips* (on page 113).

❖ *Note: After adjusting lighting, you may have to re-adjust the camera focus and/ or aperture. It may take some back and forth adjustment between lighting and focus to achieve an optimal image.*

MAINTENANCE

Refer to maintenance procedures, with attention to the following sections:

Clean the following surfaces as often as indicated in the *table* (see "Maintenance Frequency" on page 87):

- ***Glass surfaces*** (see "Cleaning Glass Surfaces" on page 88)
 - ***Camera lens*** (see "Cleaning the Camera Lens" on page 89)
 - ***Beam splitter*** (see "Cleaning the Beam Splitter" on page 89)
- ***Plastic surfaces*** (see "Cleaning Plastic Surfaces" on page 92)
 - Dome light diffuser (if present)
 - Plastic shields (if present)

- ***Ellipsoidal mirror*** (see "Cleaning the Ellipsoidal Mirror" on page 94)
- ***Part detector*** (see "Cleaning the Part Detector" on page 95)
- Cabinet and pc ***air filters*** (see "Processor Cabinet Air Filter Maintenance" on page 98)
- Oil mounting shaft on ***mounting assembly*** (see "Maintaining the Mounting Assembly" on page 96)

Chapter 15

CP/E SERIES MODULES

DESCRIPTION OF CP/E MODULES

This chapter is for Intellispec systems with models CP500E, CP750E, CP1200E, CP1500E, and other CP/E series inspection modules.

The CP/E series of inspection modules is a group of modules with similar components. The module's appearance and adjustments are similar between models. The difference between model numbers lies in the specific lighting and optics for inspection of different types of parts.

The basic components of the CP/E module are shown below.

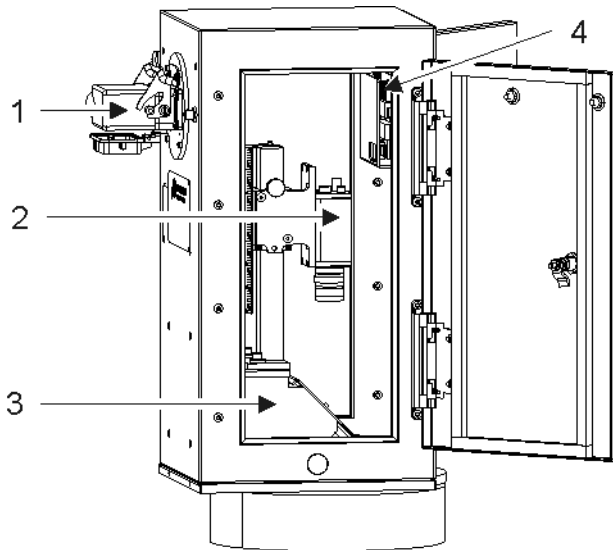

1	Umbilical connector
2	Camera
3	Fill light module with beam splitter
4	Driver board (one or two boards installed, depending on CP/E model number)

Lighting zones CP/E modules

CP500E/ CP750E

These modules use one camera and several lighting zones (see below). The camera and lighting zone configuration for CP500E and CP750E are the same; however, the angle of the lighting array of the CP500E is different than that of the CP750E. The illustration below shows the zone grouping for these modules.

These zones are programmed at Pressco and should not be changed. You may view the setup in Lighting Control > Setup > Array Configuration.

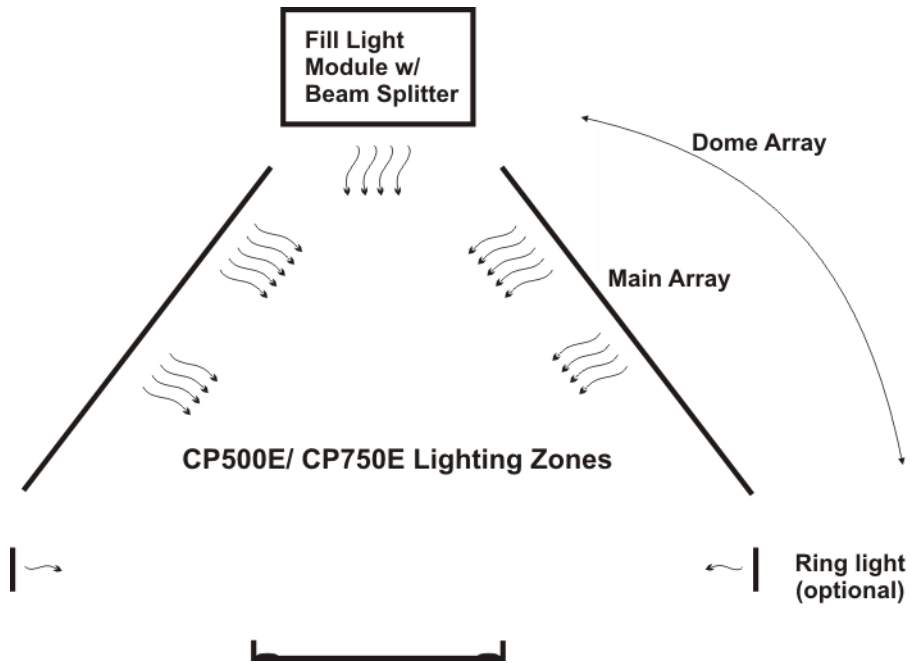

CP500E/ CP750E lighting zones		
Fill light with beam splitter (may not be present)	Main array	Ring light
4 zones: <ul style="list-style-type: none"> ▪ 1 red zone ▪ 1 green zone ▪ 1 blue zone ▪ 1 IR zone 	9 zones: <ul style="list-style-type: none"> ▪ 3 red zones ▪ 2 green zones ▪ 2 blue zones ▪ 2 IR zones 	1 zone: <ul style="list-style-type: none"> ▪ 1 red zone

CP1200E/ CP1500E

These modules use one camera and several lighting zones (see below). The zone configuration is similar between these modules, except that the CP1500E has an additional Lower Light array. The illustration below summarizes the grouping of the light zones for the CP1200E and CP1500E inspection modules.

These zones are programmed at Pressco and should not be changed. You may view the setup in Lighting Control > Setup > Array Configuration.

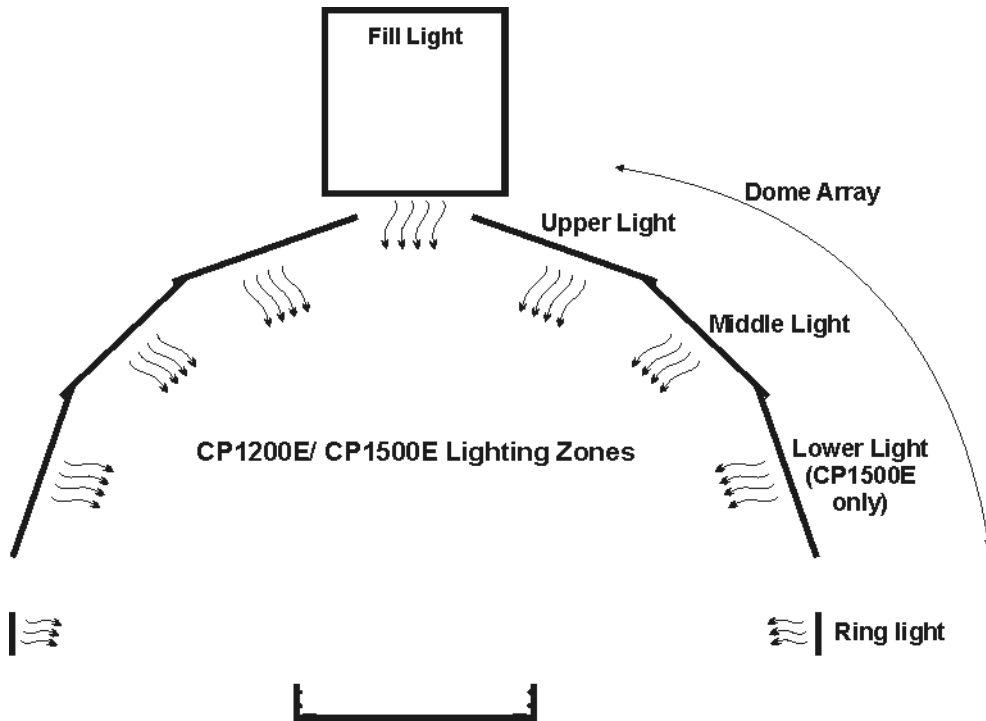

CP1200E lighting zones				
Fill light	Upper light	Middle light	Ring light (optional)	
4 zones: ▪ 1 red zone ▪ 1 green zone ▪ 1 blue zone ▪ 1 IR zone	9 zones: ▪ 3 red zones ▪ 2 green zones ▪ 2 blue zones ▪ 2 IR zones	8 zones: ▪ 2 red zones ▪ 2 green zones ▪ 2 blue zones ▪ 2 IR zones	4 zones: ▪ 1 red zone ▪ 1 green zone ▪ 1 blue zone ▪ 1 IR zone	OR: ▪ 2 red zones ▪ 2 blue zones OR: ▪ 4 red zones OR: ▪ 1 red zone

CP1500E					
Fill light	Upper light	Middle light	Lower light	Ring light	
4 zones: ▪ 1 red zone ▪ 1 green zone ▪ 1 blue zone ▪ 1 IR zone	9 zones: ▪ 3 red zones ▪ 2 green zones ▪ 2 blue zones ▪ 2 IR zones	8 zones: ▪ 2 red zones ▪ 2 green zones ▪ 2 blue zones ▪ 2 IR zones	8 zones: ▪ 2 red zones ▪ 2 green zones ▪ 2 blue zones ▪ 2 IR zones	4 zones: ▪ 1 red zone ▪ 1 green zone ▪ 1 blue zone ▪ 1 IR zone	OR: ▪ 2 red zones ▪ 2 blue zones OR: ▪ 4 red zones OR: ▪ 1 red zone

INTERCONNECT DIAGRAM CP/E MODULES SERIES IV

Interconnect diagram for Intellispec Series IV - CP/E series inspection modules (2 Lanes shown)

Not all systems have Light Tree. In these cases, keyboard hooks up directly to cabinet - not through umbilical.

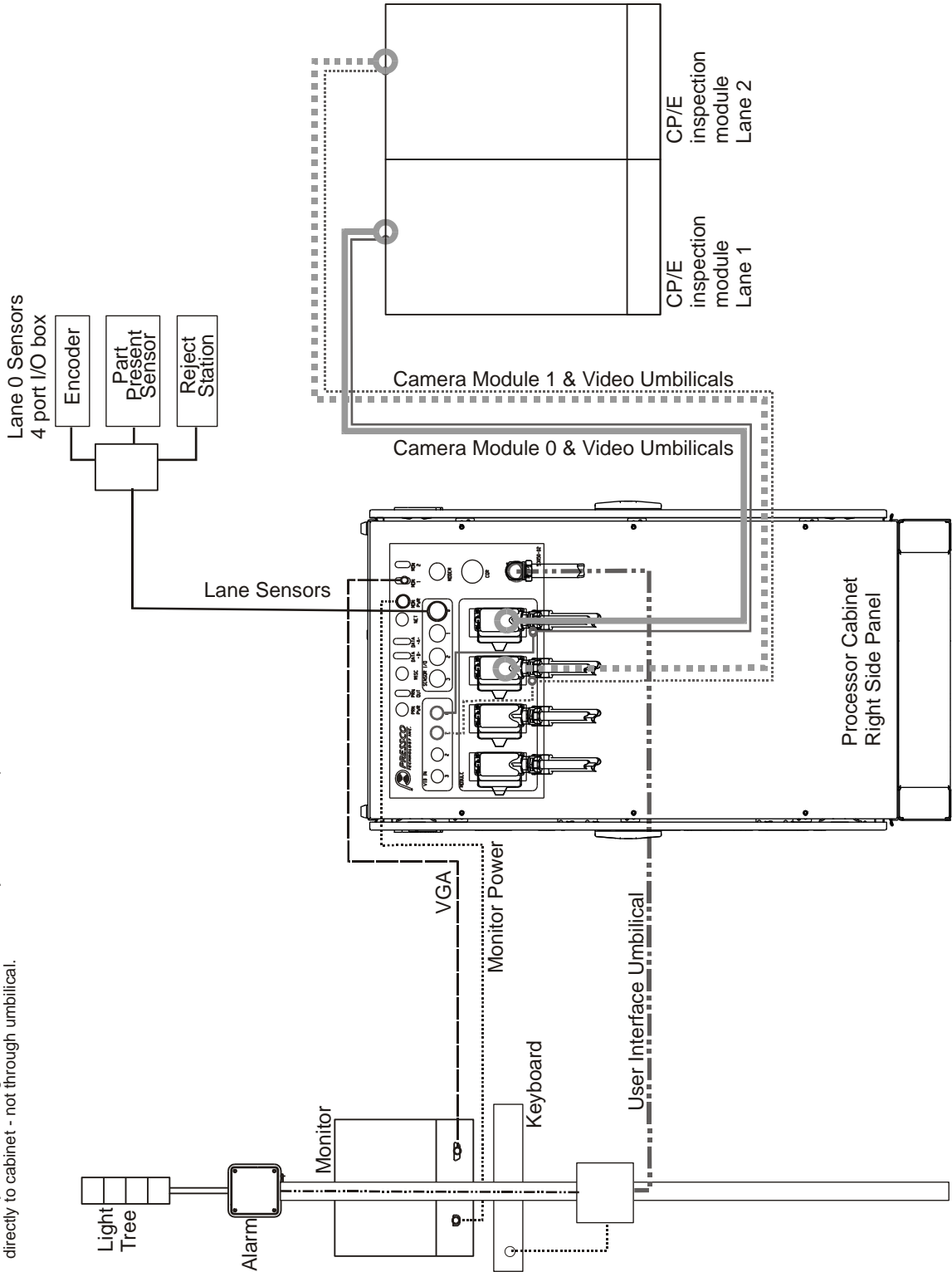

ADJUSTING THE CP/E SERIES MODULE

This section covers camera adjustments that may be required to keep the inspection modules working properly. Adjustments include the camera position, aperture, and camera focus.

The focus adjustment controls the clarity of the image; the aperture adjustment controls the amount of light admitted by the shutter. Normally the inspection modules do not require further adjustment after initial system setup. Circumstances that might require additional adjustments are camera replacement, strobe replacement, or a substantial change in part size or color.

DANGER

The inspection modules are mounted near moving machinery. Use extreme caution to avoid contact with moving machinery when servicing inspection modules as serious personal injury could result. Ensure machinery is in an emergency stop state before servicing inspection modules.

Adjust module height

The height of the module is easily adjusted. Refer to the illustration below. Loosen either knob [item 1 or 3] and use the handle [item 2] to move the module up or down. You can move the module with one hand while viewing the image on the monitor. Tighten the knob when desired height is achieved.

Adjust for different part size

- Move the module up or down to increase or decrease the size of the part image – view monitor while adjusting module.
- Use *camera position adjustment* (on page 173) to adjust for small change in part size
- The adjustable stops [items 4 and 5] can be used to mark where the module is supposed to rest. For example, the bottom stop [item 5] can be placed at the module’s lowest inspection height. You can easily raise the module to clean or clear jams, then lower the module back down to the stop.
- The top stop [item 4] can be used to mark the module’s highest inspection height – for your largest inspected part.

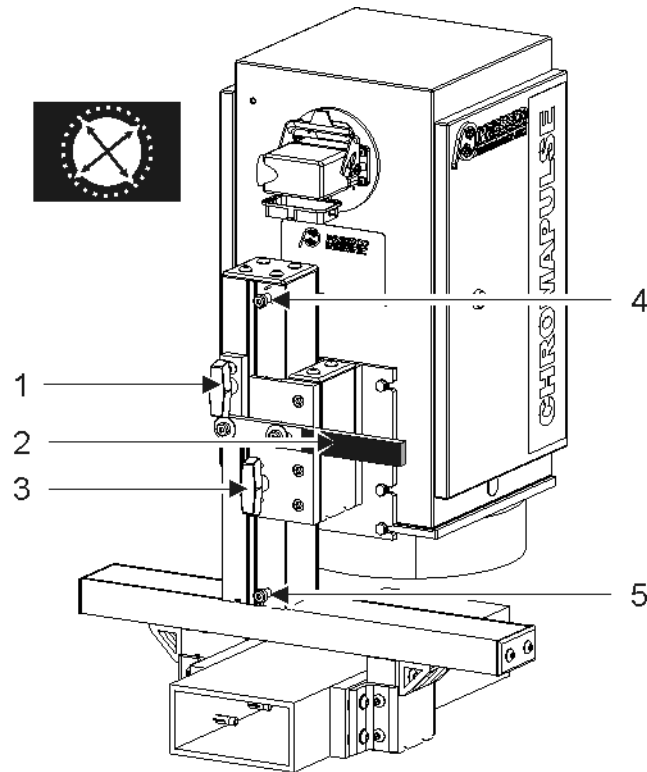

1 or 3	Knob - loosen to move module, or tighten to secure module in place
2	Handle - use to move module up or down
4	Adjustable stop - highest inspection position
5	Adjustable stop - lowest inspection position

To adjust module height:

1. Loosen knob [item 1 or 3].
2. Use handle [item 2] to move module up or down.
3. Tighten knob [item 1 or 3].



Switch sides

The CP/E series modules are designed for maximum flexibility to fit into your production line. During installation, the module can be changed so that the height adjustment brackets can be placed on the other side of the module.

Likewise, the doors of the module may be removed and their hinges attached to the other side, for the door to swing oppositely.

Observe Part Image

When adjusting the focus, aperture, or height, it is helpful to place the Intellispec System in the Live Image mode so you can immediately see the effect of an adjustment on the image quality.

With the system Offline, choose the correct camera view > right-click the Snap button  > and choose  Live Images. If the production line is not running, place a part in the camera view as it would be during normal production.

Focus Adjustments

To adjust focus, carefully remove or open the inspection module cover. Turn the focus adjust ring while observing the part image on the monitor. Adjust the focus for the sharpest image. If needed, adjust the *aperture* (see "Aperture Adjustment" on page 124), then reinstall the cover.

Camera Position Adjustment

❖ *Note: Normally, you do not need to adjust camera position. Adjust only if you are initially installing, or have replaced the inspection module.*

The cameras can be adjusted for image size and position. Carefully remove the side panel cover of the inspection module. Adjust cameras as necessary while observing image on Intellispec monitor. After making all camera adjustments, replace module cover.

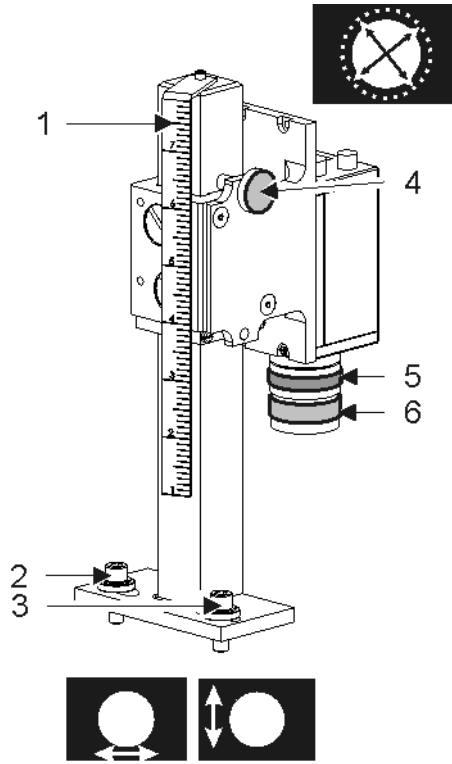

1	Note camera position on scale when adjusting for your part
2, 3	Additional camera position adjustments - horizontal or vertical on Intellispec image
4	Camera position - adjust for image size
5	Focus adjustment
6	Aperture adjustment

Replacing Camera

On rare occasion, you may need to replace a camera in a CP/E inspection module.

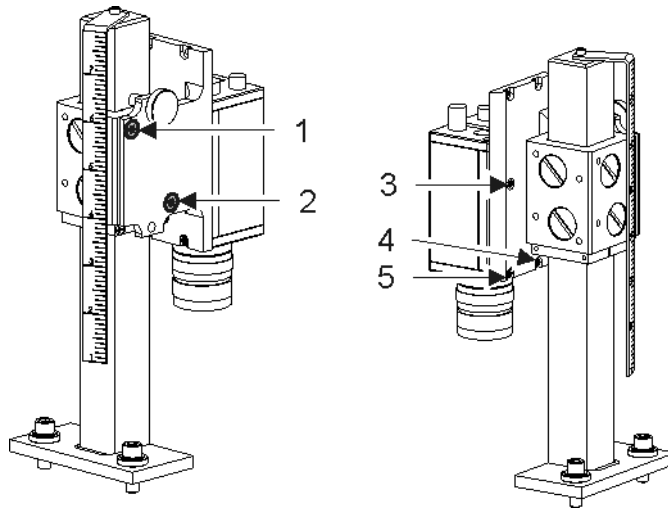

To replace camera:

1. Remove the two screws [items 1 and 2].
2. Remove camera from mounting plate and attach new camera.
3. Tighten two screws [items 1 and 2].
4. If necessary, adjust the screws attached to camera bracket [items 3, 4, 5] to square the image on screen.

Lighting Adjustments

Aperture Adjustment

The aperture controls the amount of light that passes through the lens. The programmable light source provides the range of light intensity required for most applications. However, you can manually adjust the aperture if necessary by turning the aperture adjust ring on the camera lens. Reinstall the cover.

Adjust Lighting Through Software

Using SmartLight in the software, adjust the lighting to optimize the contrast of the defects. Also refer to *lighting setup tips* (on page 113).

❖ *Note: After adjusting lighting, you may have to re-adjust the camera focus and/ or aperture. It may take some back and forth adjustment between lighting and focus to achieve an optimal image.*

MAINTENANCE

Refer to maintenance procedures, with attention to the following sections:

Clean the following surfaces as often as indicated in the *table* (see "Maintenance Frequency" on page 87) :

- **Glass surfaces** (see "Cleaning Glass Surfaces" on page 88)
 - **Camera lens** (see "Cleaning the Camera Lens" on page 89)
 - **Beam splitter** (see "Cleaning the Beam Splitter" on page 89)
- **Plastic surfaces** (see "Cleaning Plastic Surfaces" on page 92)
 - **Plastic shield** (see "Modules with Plastic Shields" on page 95)
- **Ellipsoidal mirror** (see "Cleaning the Ellipsoidal Mirror" on page 94) (if applicable)
- **Part detector** (see "Cleaning the Part Detector" on page 95)
- Cabinet and pc **air filters** (see "Processor Cabinet Air Filter Maintenance" on page 98)

Chapter 16

CABLE WIRING DIAGRAMS

Many of the cables included in this section are those that connect from the Main I/O to other components of the Intellispec cabinet, or gland plate. Also included are many inspection module cables and umbilicals.

❖ *Tip: to locate a cable, use the search feature to type a part number or partial cable description.*

To use Adobe Acrobat's search feature:

Type a word (or part number) in the search box and press ENTER. If more than one instance is available, use the FIND NEXT or FIND PREVIOUS buttons to find other instances.

OR:

Click the drop-down arrow for more search features. Follow the instructions on screen.

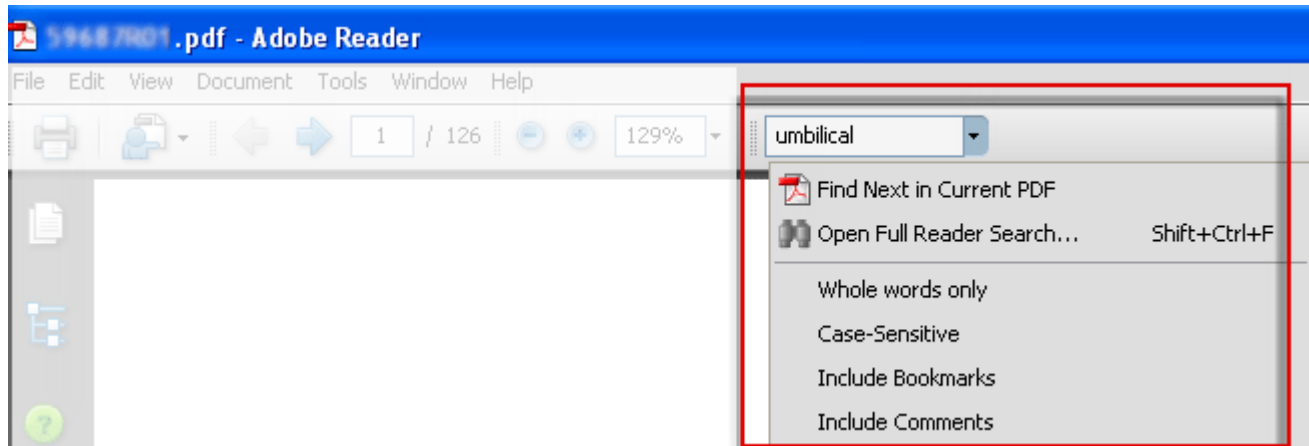

Your screen and options may be different, depending what version of Adobe Acrobat you are using.

CABINET CABLES

45914 UPS shutdown control

J19 - UPS Port Cable

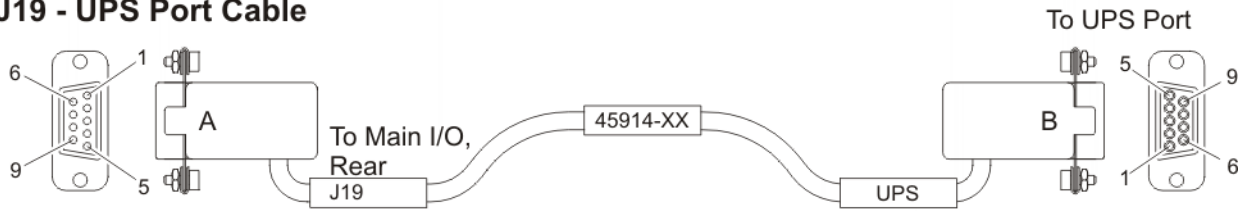

Wiring Chart			
Pin Number 9P "A" Connector	Wire Color	Pin Number 9p "B" Connector	Description
1	BKL	5	Low Battery\DCD
2,3	-	-	N/C
4	WHT	1	UPS Shutdown\DTR
5	GRN	4	Ground
6,7	-	-	N/C
8	RED	2	Power Failure\CTS
9	-	-	N/C

Main I/O
UPS

45899 Power status

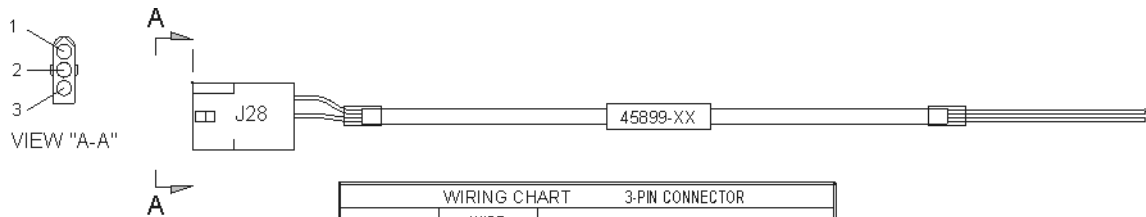

WIRING CHART 3-PIN CONNECTOR		
PIN NUMBER	WIRE COLOR	DESCRIPTION
1	RED	POWER-STATUS-BIT
2	BLK	GND-ISOL
3	-	N/C

45861 Power Main I/O 5/12/12L/48V

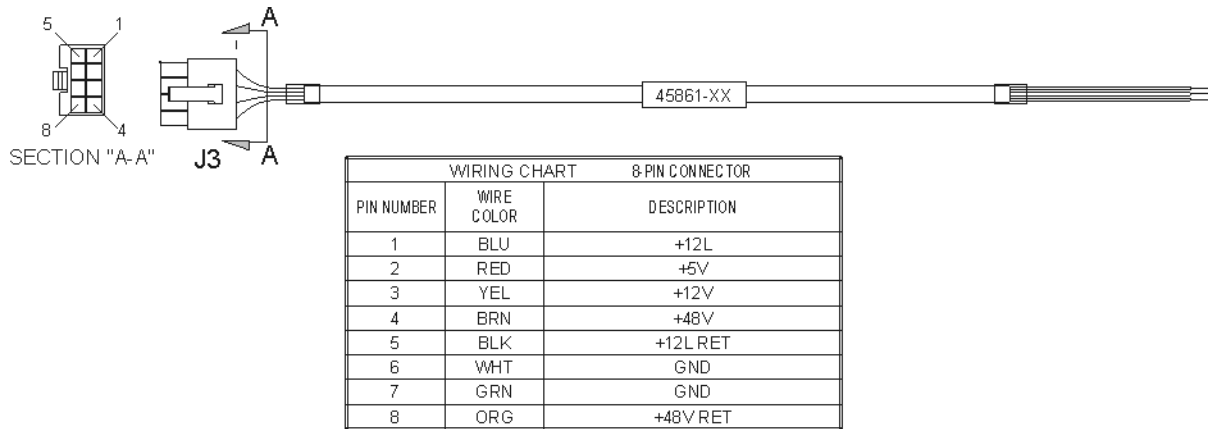

45862 Power Main I/O 12/24V Isolated

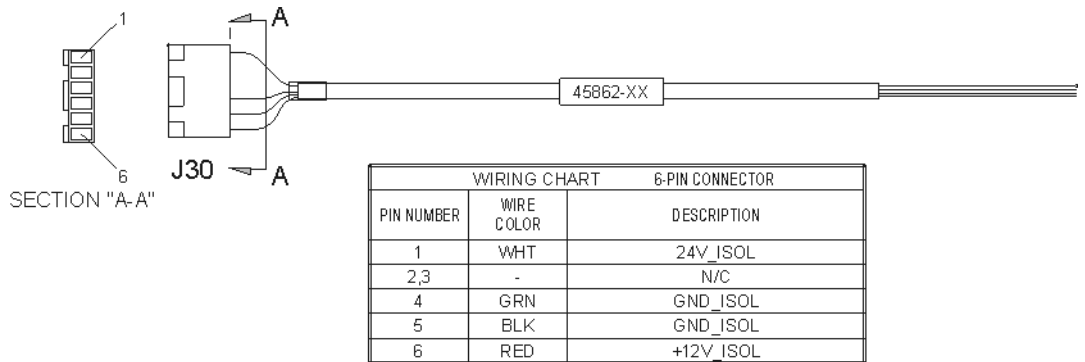

46237 serial connector DB37M - DB37F

J18 - Serial Connector

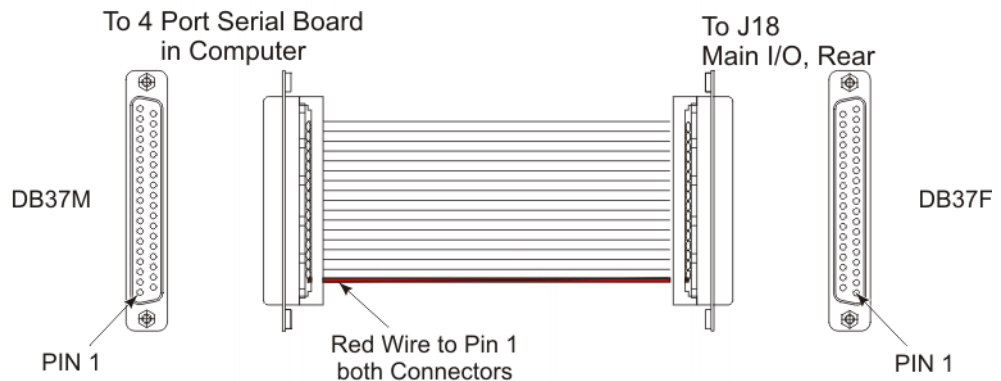

For signals, see "Communication Port Test Points" TP4 signals in table "Signals Available for Checking" in this manual.

46232 thermostat

J27 - Overtemp Sensor

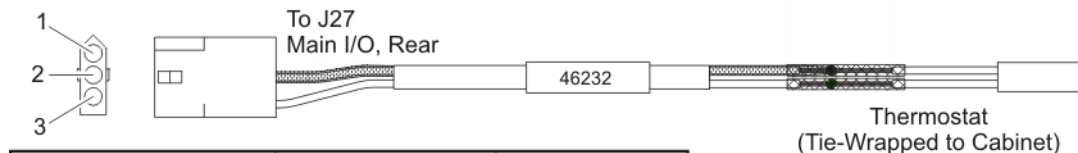

Pin Number 3-Pin Connector	Wire Color	Thermostat
1	N/C	N/C
2	BLK	-
3	RED	+

52886 overtemp sensor air conditioner

J29 - Overtemp Sensor Air conditioner

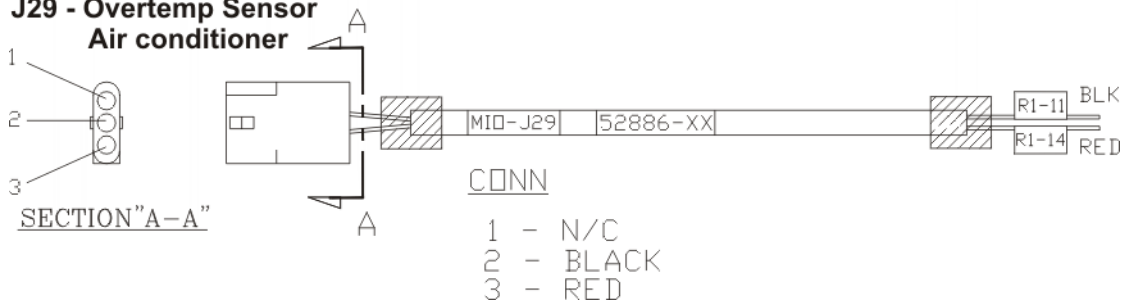

45905 cable 4 port distribution box internal

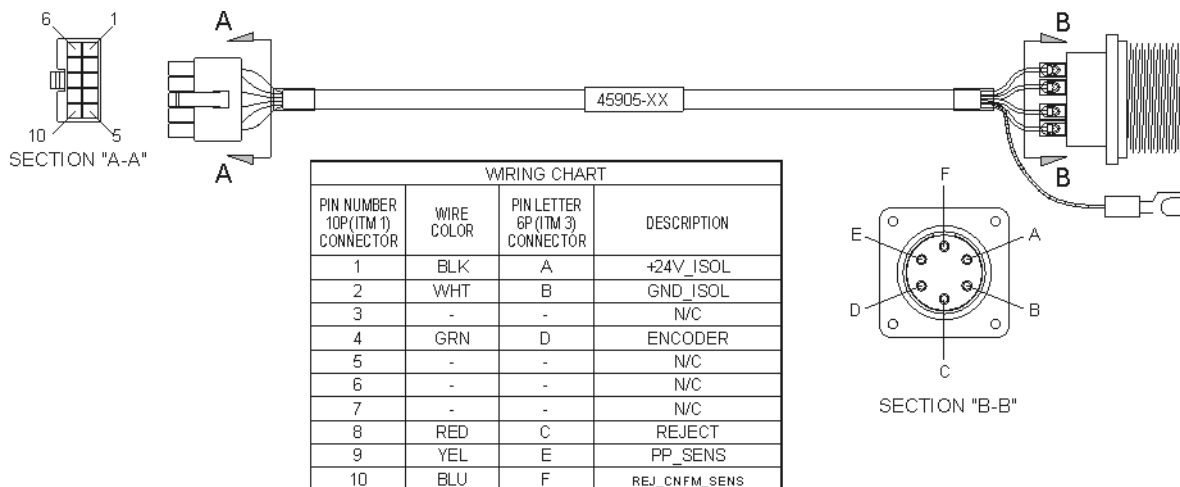

45906 cable 8 port distribution box internal

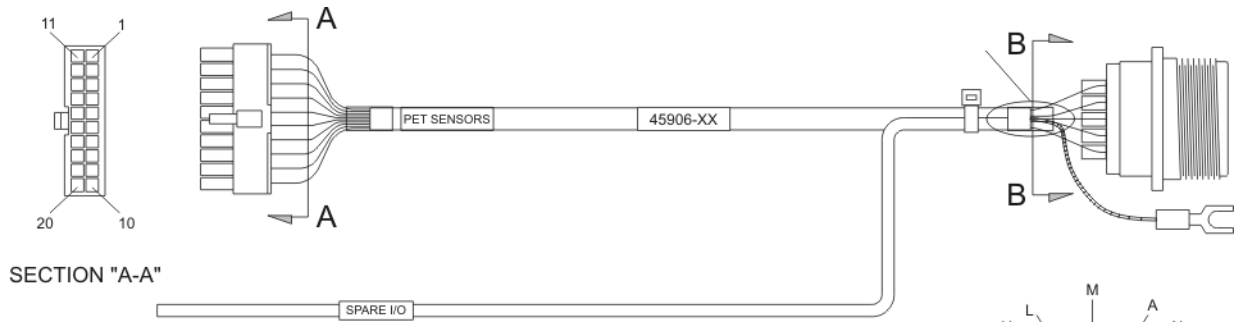

WIRING CHART -ITEM 1 CABLE			
PIN NUMBER 20-PIN CONNECTOR	WIRE COLOR	PIN LETTER 19-PIN CONNECTOR	DESCRIPTION
1	-	-	-
2	RED	C	SP_IND_X_SENS (JP6-1)
3	ORG	E	DOOR_OPEN_SENS (JP4-1)
4	WHT/BLK	G	REJFULL_SENS (JP3-3)
5	GRN/BLK	J	CAV_IND_X_SENS (JP7-3)
6	-	-	-
7	RED/WHT	M	PKT_DET_SENS (JP8-3)
8	BLU/WHT	P	REJFULL_SENS (JP3-1)
9	WHT/RED	S	CAV_IND_X_SENS (JP7-1)
10	BLU/RED	U	+24V_ISOL
11	WHT	B	PKT_DET_SENS (JP8-1)
12	GRN	D	DOOR_OPEN_SENS (JP4-3)
13	BLU	F	GND_ISOL
14	RED/BLK	H	TA_IND_X_SENS (JP5-3)
15	ORG/BLK	K	SPARE_SENS_A (JP9-3)
16	-	-	-
17	GRN/WHT	N	SP_IND_X_SENS (JP6-3)
18	BLK/RED	R	TA_IND_X_SENS (JP5-1)
19	ORG/RED	T	SPARE_SENS_B (JP10-3)
20	RED/GRN	V	+12V_ISOL

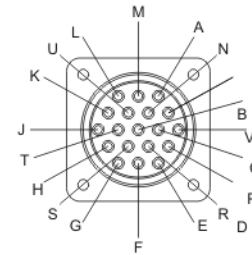

SECTION "B-B"

WIRING CHART -ITEM 10 CABLE			
PIN NUMBER 20-PIN CONNECTOR	WIRE COLOR	PIN LETTER 19-PIN CONNECTOR	DESCRIPTION
-	BLK	L	SPARE_SENS_A (JP9-1)
-	RED	A	SPARE_SENS_B (JP10-1)

45999 8 port I/O box



WIRING CHART		SEE NOTE 6	
PIN LETTER	WIRE COLOR	DESCRIPTION	PORT-PIN NUMBER
A	VIO	SPARE B-1	8-4
B	RED	PKT_DET-1	6-4
C	GRY	SP_IND-1	4-4
D	RED/BLU	DOOR OPEN-2	2-2
E	GRN	DOOR OPEN-1	2-4
F	BLU	GND	ALL-3
G	GRY/PNK	REJFULL-2	1-2
H	WHT/GRN	TA_IND-2	3-2
J	WHT/YEL	CAV_IND-2	5-2
K	WHT/GRY	SPARE A-2	7-2
L	BLK	SPARE A-1	7-4
M	YEL/BRN	PKT_DET-2	6-2
N	BRN/GRN	SP_IND-2	4-2
P	WHT	REJFULL-1	1-4
R	YEL	TA_IND-1	3-4
S	PNK	CAV_IND-1	5-4
T	GRY/BRN	SPARE B-2	8-2
U	BRN	+24V	ALL-1
V	NIC	-	-

DISTRIBUTION BOX LABEL CHART	
PORT	LABEL
1	REJ FULL
2	DOOR OPEN
3	TA_IND
4	SP_IND
5	CAV_IND
6	PKT_DET
7	SPARE_A
8	SPARE_B

2-LANE CORRELATION LABEL CHART	
PORT	LABEL
1	REJ FULL
2	DOOROPEN
3	MACHPRT_2
4	PKT_DET_2
5	MACHPRT_1
6	PKT_DET_1
7	SPARE_A
8	SPARE_B

46000 4 port I/O box

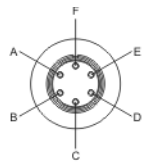

SECTION "A-A"



WIRING CHART		6 - PIN CONNECTOR	
	WIRE COLOR	DESCRIPTION	PORT-PIN NUMBER
A	BRN	+24V	ALL-1
B	BLU	GND	ALL-3
C	YEL	REJECT	3-4
D	GRN	ENCODER	2-4
E	WHT	PART DETECT	1-4
F	GRY	REJ CNFM	4-4

DISTRIBUTION BOX LABEL CHART	
PORT	LABEL
1	P.D.
2	ENC
3	REJ
4	REJ CFM

Umbilical user interface

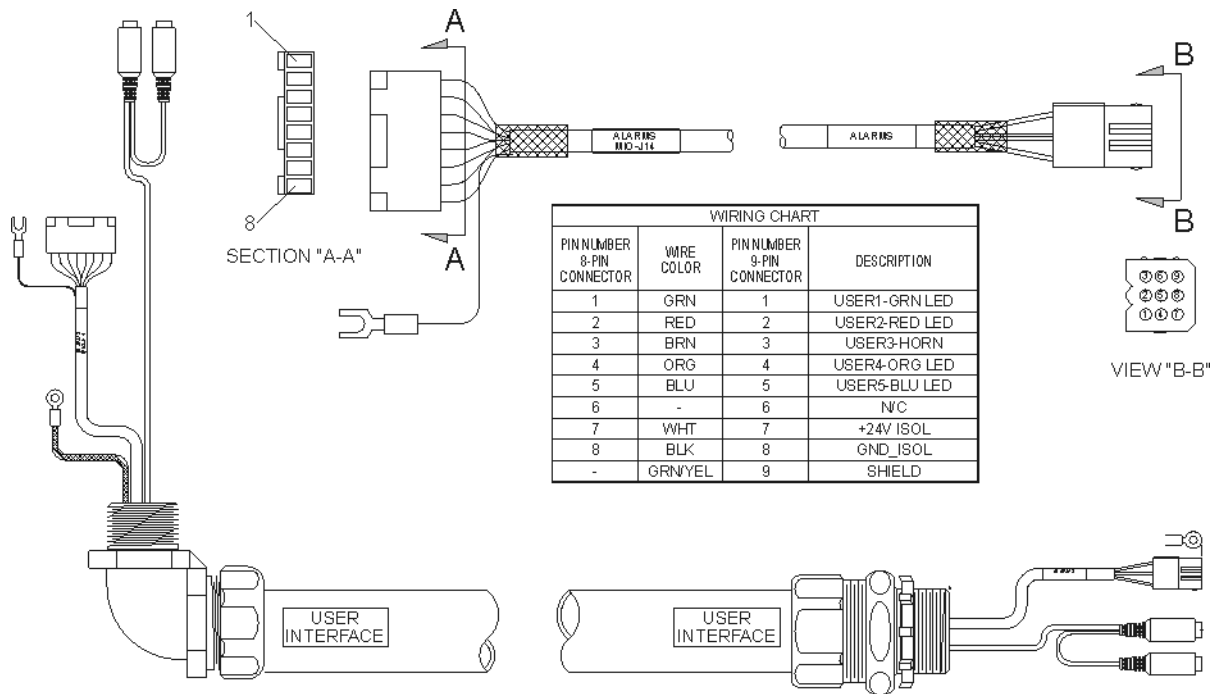

USER1	light tree green light - online status
USER2	light tree red light - visible alarm
USER3	audible alarm
USER4	light tree yellow light - warning indicator
USER5	light tree blue light - AC present

48190 cable light tree

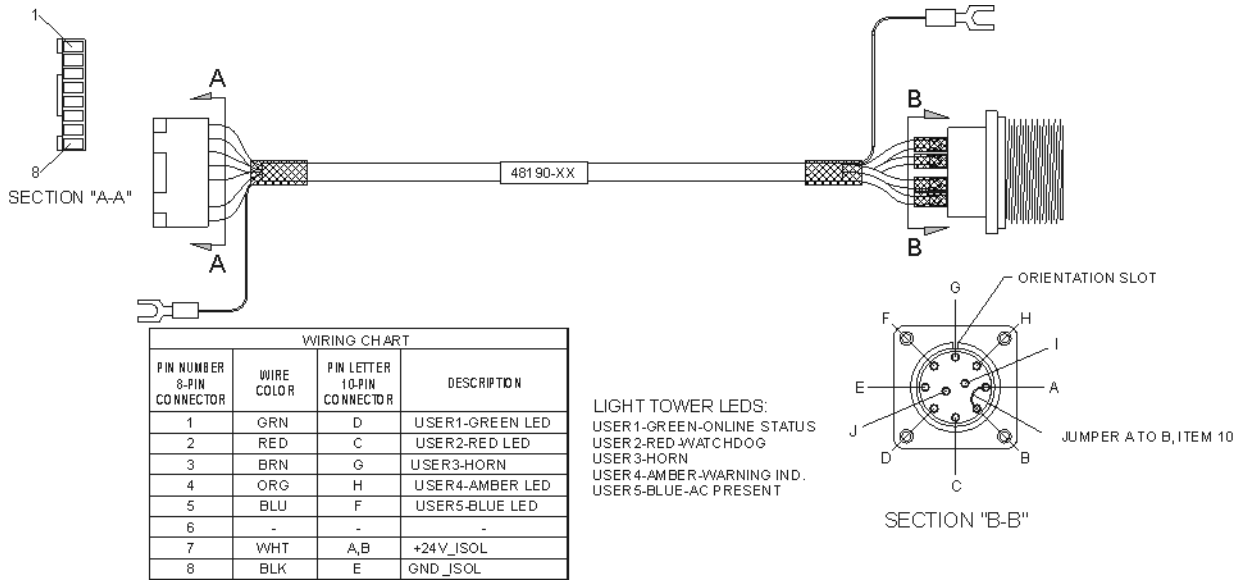

48167 cable light tree junction box

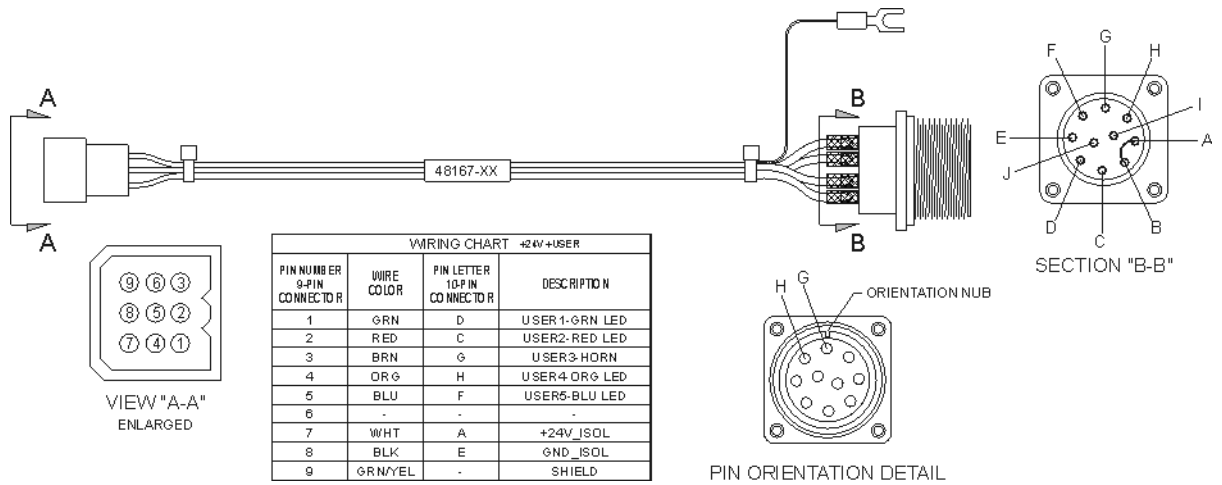

CHROMAPULSE CABLES

CP1500 Module

49444 dome array pigtail

Chromapulse Cable Dome Array Pigtail

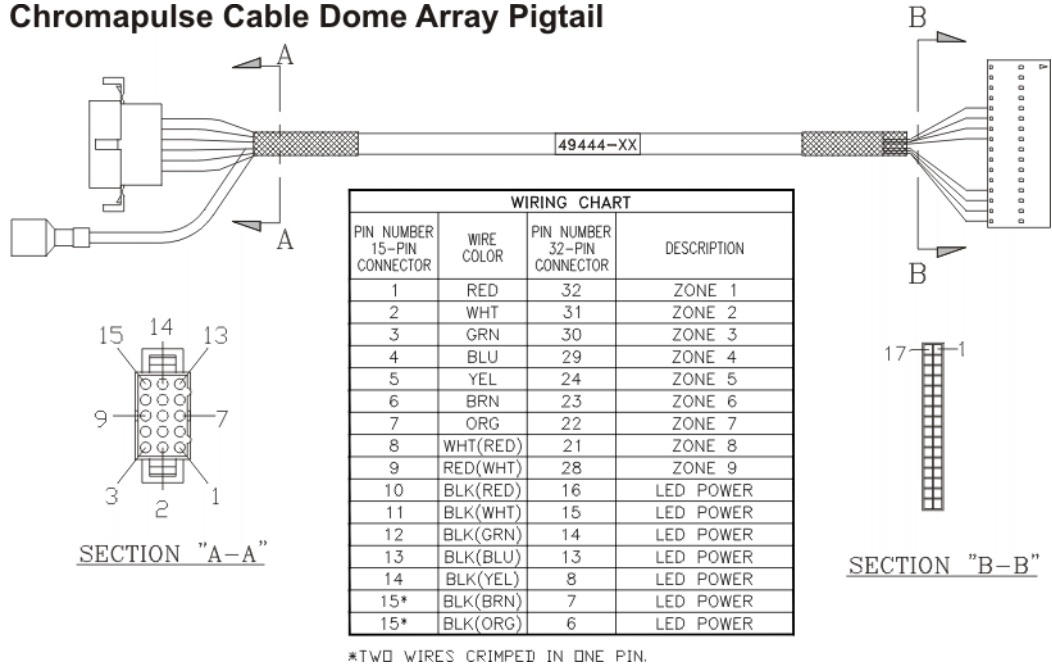

44403, 44461, 59413 Chromapulse LED power

Also 59413 in CP4422E

Chromapulse LED power

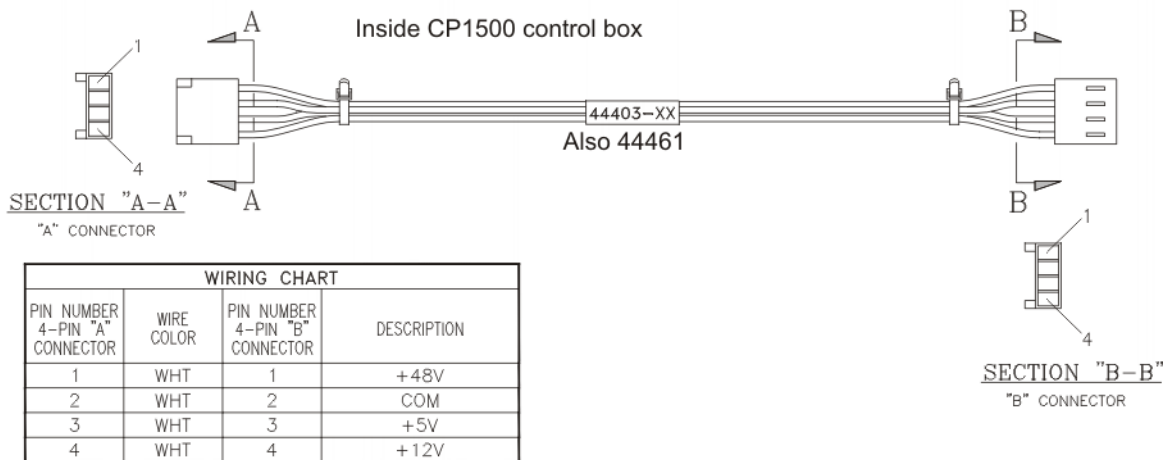

50726 Chromapulse panel array pigtail
Chromapulse Cable Panel Array Pigtail

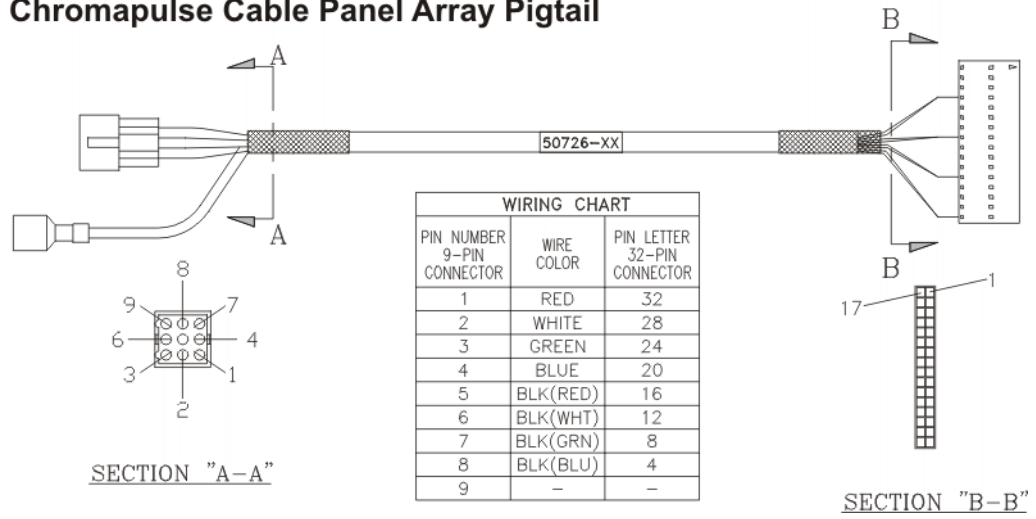

44599,44407 Chromapulse camera control
Chromapulse Camera Control for CP1500

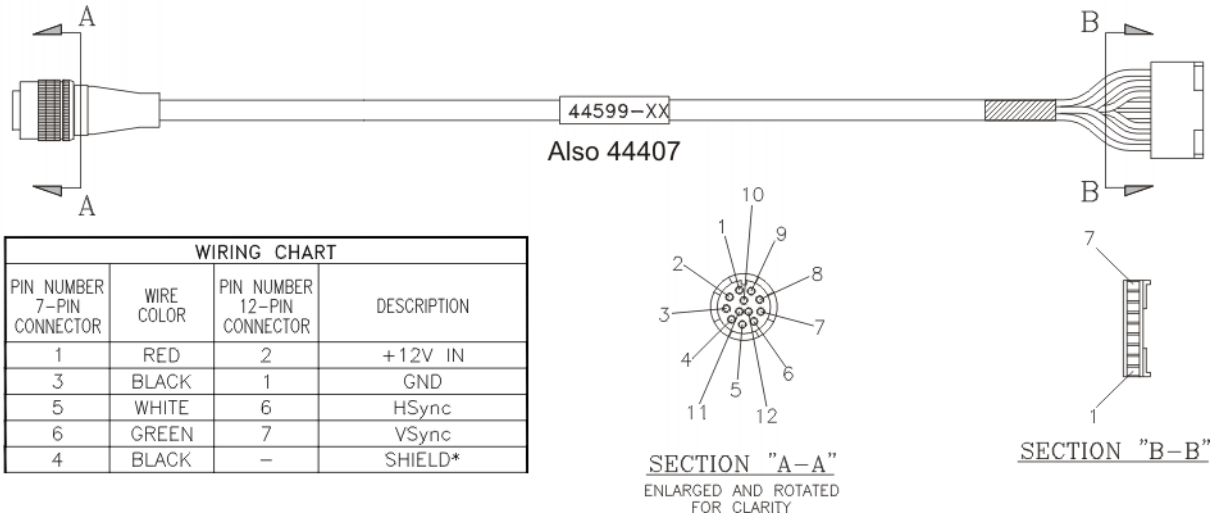

44404, 44462, 59414 Chromapulse LED signal

Also 59414 in CP4422E

Chromapulse LED signal

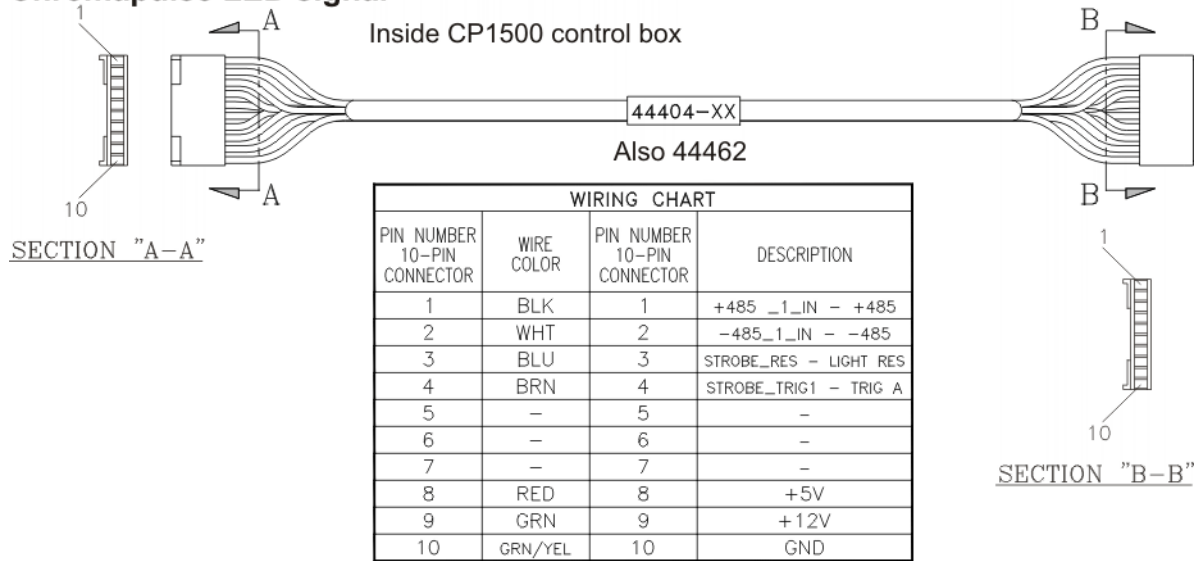

44405, 44463, 59415 RS485 signal return

Also 59415 in CP4422E

Chromapulse RS485 Signal Return

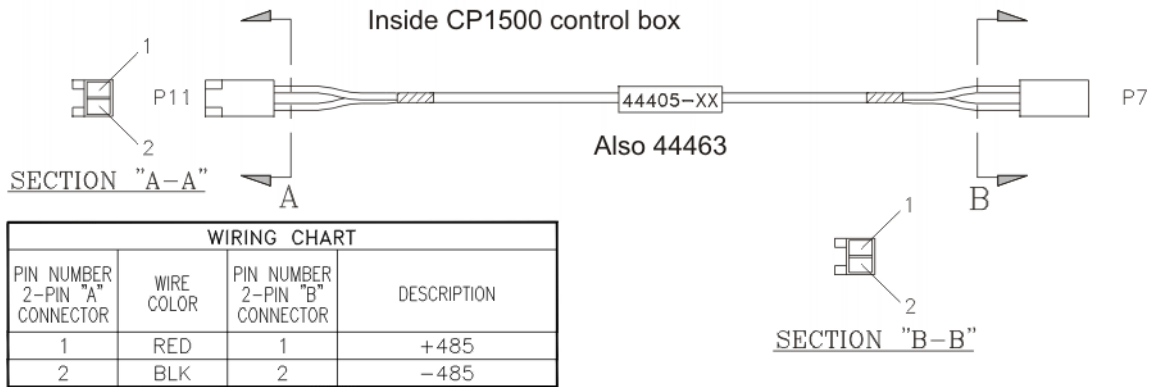

CP750E Module (old style)

49397, 49391 CP750E umbilical panel/ dome/ ring

Chromapulse CP750E Control Box Umbilical Panel/ Dome/ (Ring), 1 Tap

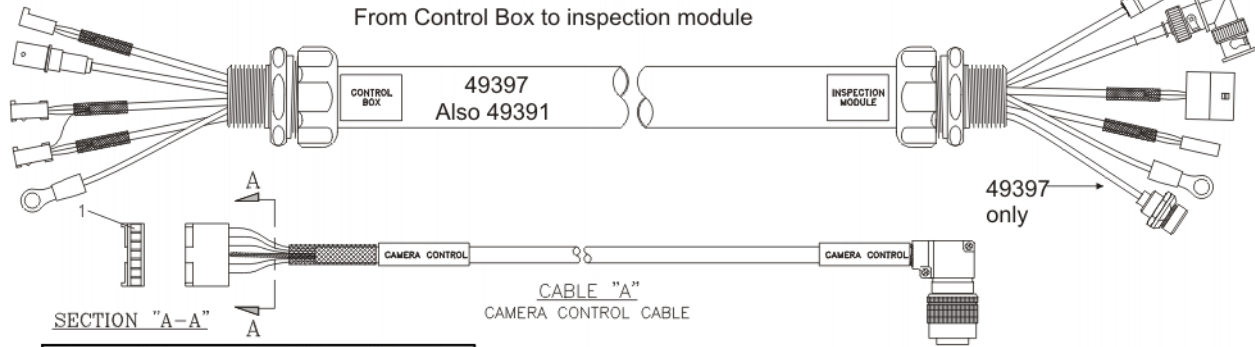

WIRING CHART			
PIN NUMBER 7-PIN CONNECTOR	WIRE COLOR	PIN NUMBER 10-PIN CONNECTOR	DESCRIPTION
1	WHT	2	12V
2	-	-	N/C
3	BLK	1	GND
4	DRAIN	-	SHIELD
5	RED	6	HYSNC
6	GRN	7	VSYNC
7	-	-	N/C

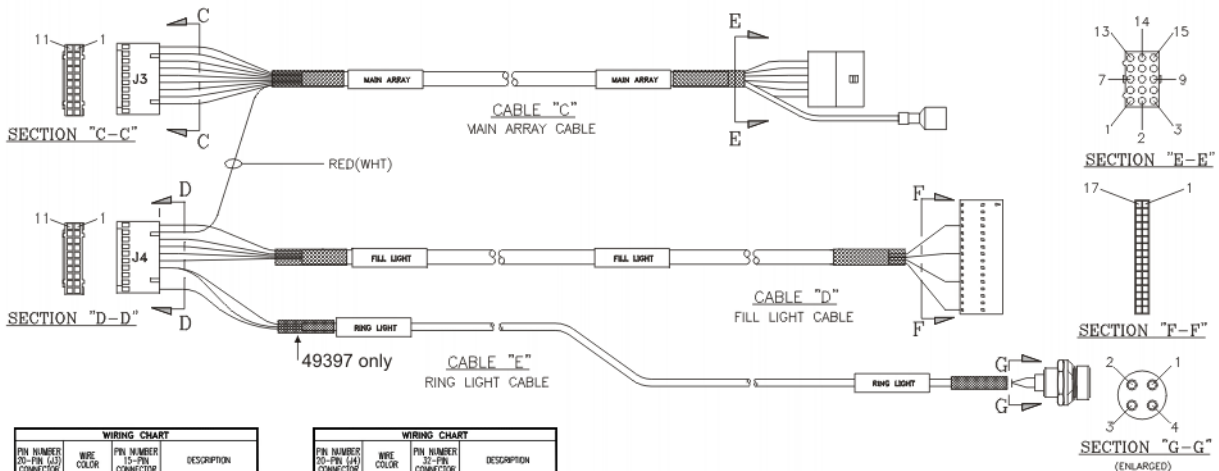
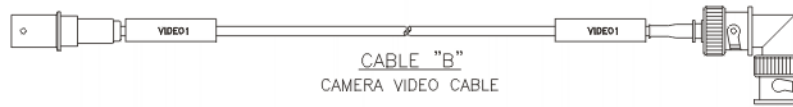

WIRING CHART			
PIN NUMBER 20-PIN (L4) CONNECTOR	WIRE COLOR	PIN NUMBER 15-PIN CONNECTOR	DESCRIPTION
1	SHIELD	-	-
2	RED	1	ZONE 1
3	WHT	2	ZONE 2
4	GRN	3	ZONE 3
5	BLU	4	ZONE 4
6	YEL	5	ZONE 5
7	BRN	6	ZONE 6
8	ORG	7	ZONE 7
9	WHT(RED)	8	ZONE 8
10, 11	-	-	-
12	BLK(RED)	10	LED POWER
13	BLK(WHT)	11	LED POWER
14	BLK(GRN)	12	LED POWER
15	BLK(BLU)	13	LED POWER
16	BLK(YEL)	14	LED POWER
17	BLK(BRN)	15*	LED POWER
18	BLK(ORG)	15*	LED POWER
19, 20	-	-	-

*12 WIRES CRIMPED IN 1 PIN.

WIRING CHART			
PIN NUMBER 20-PIN (L4) CONNECTOR	WIRE COLOR	PIN NUMBER 33-PIN CONNECTOR	DESCRIPTION
1	SHIELD	-	-
2	-	-	-
3	RED	32	ZONE 1
4	WHT	28	ZONE 2
5	GRN	24	ZONE 3
6	BLU	20	ZONE 4
7-9	-	-	-
11	-	-	-
12	-	-	-
13	BLK(RED)	16	LED POWER
14	BLK(WHT)	12	LED POWER
15	BLK(GRN)	8	LED POWER
16	BLK(BLU)	4	LED POWER
17-20	-	-	-

WIRING CHART			
PIN NUMBER 20-PIN (L4) CONNECTOR	WIRE COLOR	PIN NUMBER 15-PIN CONNECTOR	DESCRIPTION
2	RED(WHT)	9	ZONE 9

This chart 49397 only

WIRING CHART			
PIN NUMBER 20-PIN (L4) CONNECTOR	WIRE COLOR	PIN NUMBER 4-PIN CONNECTOR	DESCRIPTION
7	RED	1	RING LIGHT
-	-	2	-
10	DRAIN	-	SHIELD
17	BLK	3	LED POWER

CP500/ CP750 Modules

47655 camera control

Chromapulse Camera Control for CP750 & CP500

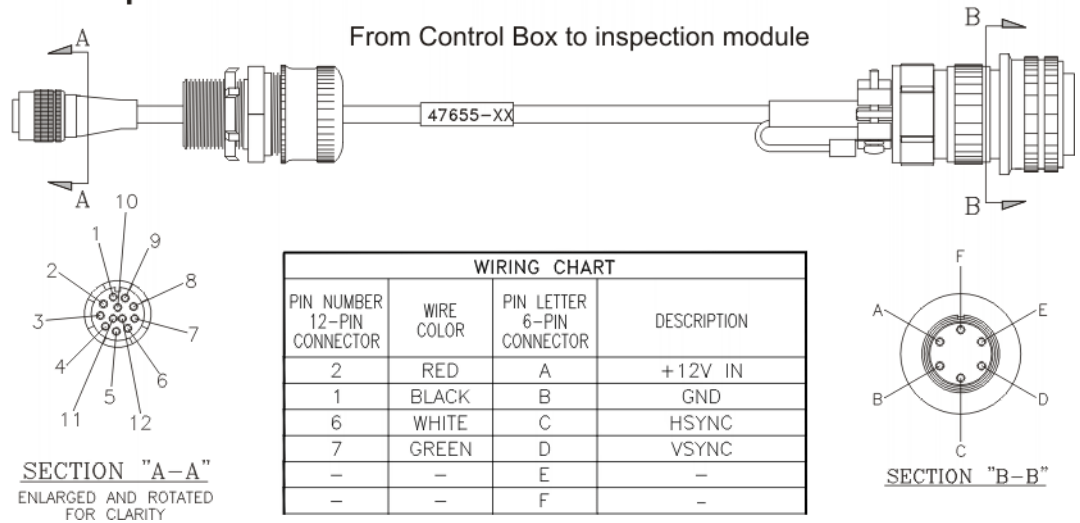

49477, 49520, 47654 camera control

Chromapulse Camera Control Box for CP750 & CP500

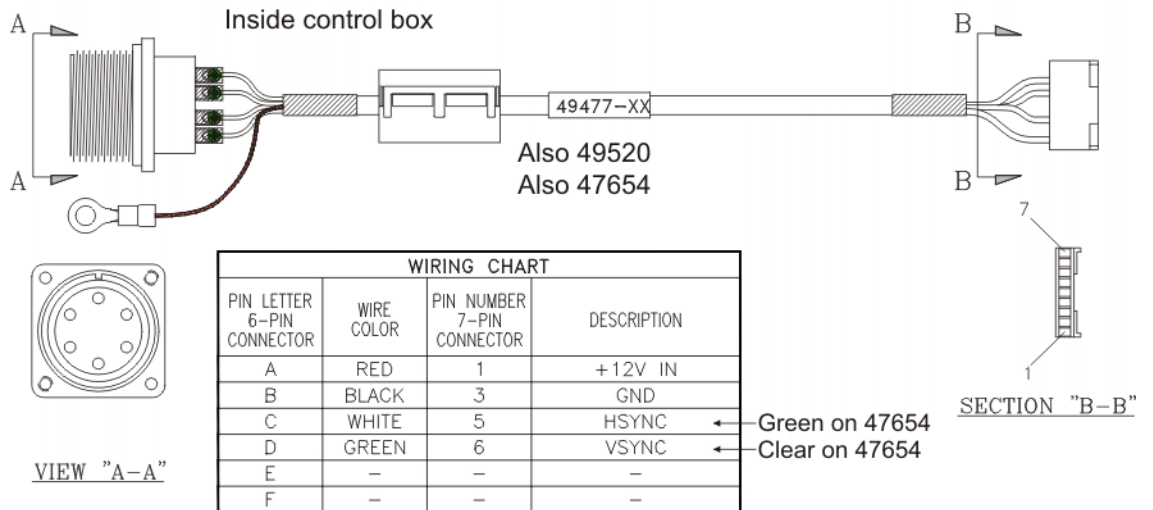

56187 GIG-E Camera Control CP500/750

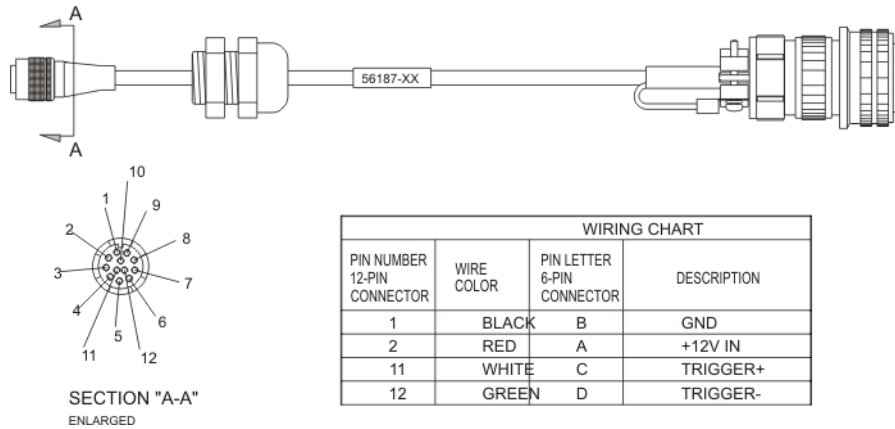

Cable GIG-E camera control CP500 ctrl box 56186

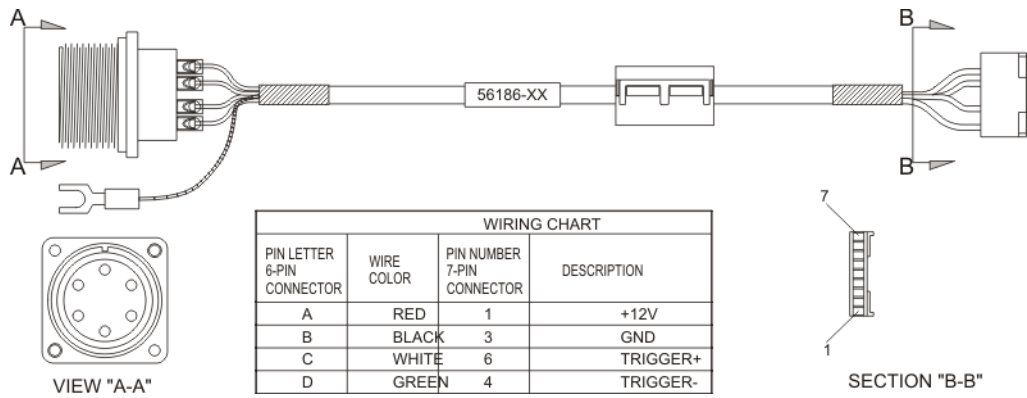

59118 GIG-E camera control CP500/750R

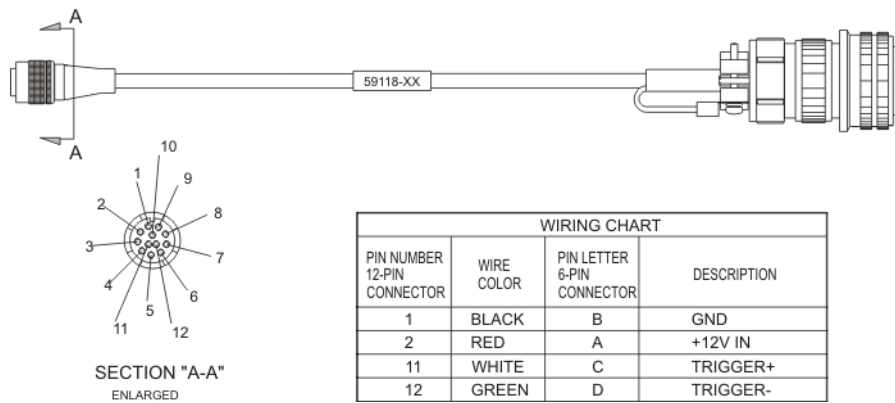

Belvac inspection modules

48825 Chromapulse IC1 ring arrays

Chromapulse Ring Arrays for IC1

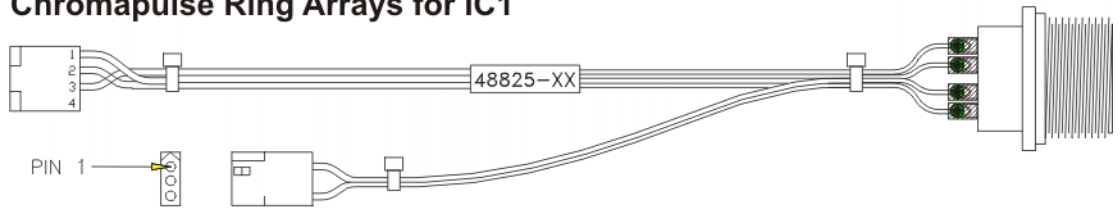

WIRING CHART			
PIN NUMBER 4-PIN CONNECTOR	WIRE COLOR	PIN LETTER 5-PIN CONNECTOR	DESCRIPTION
1	RED	A	+48V
2	WHT	B	ZONE1
3	BLU	C	ZONE2
4	-	-	-

WIRING CHART			
PIN NUMBER 3-PIN CONNECTOR	WIRE COLOR	PIN LETTER 5-PIN CONNECTOR	DESCRIPTION
1	RED	D	+48V
2	-	-	-
3	BLK	E	ZONE1

Chromapulse LED power

50538, 52013, 53660, 53661

Chromapulse LED power

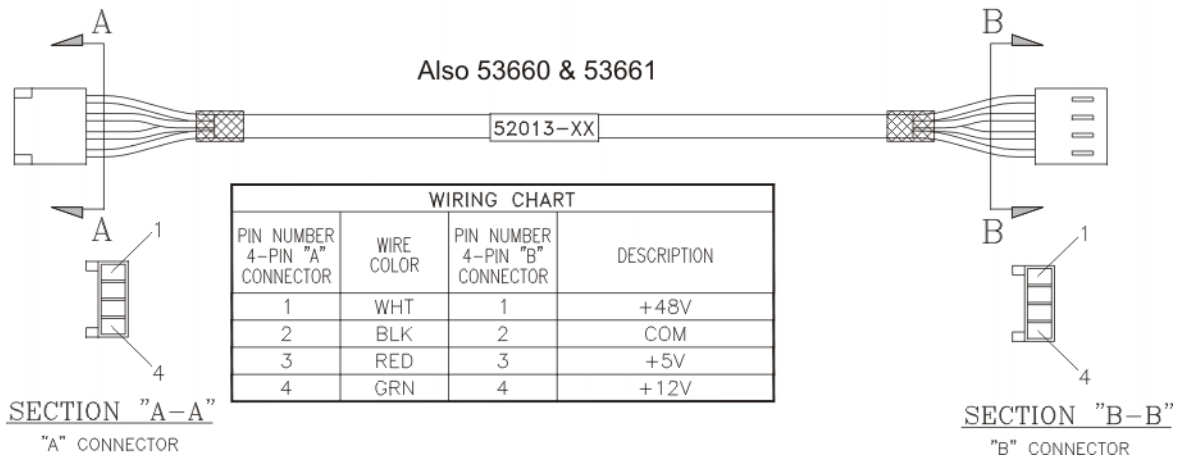

48880, 50423 Chromapulse RS485 comm. video mux.

Chromapulse RS485 Comm. Video Mux

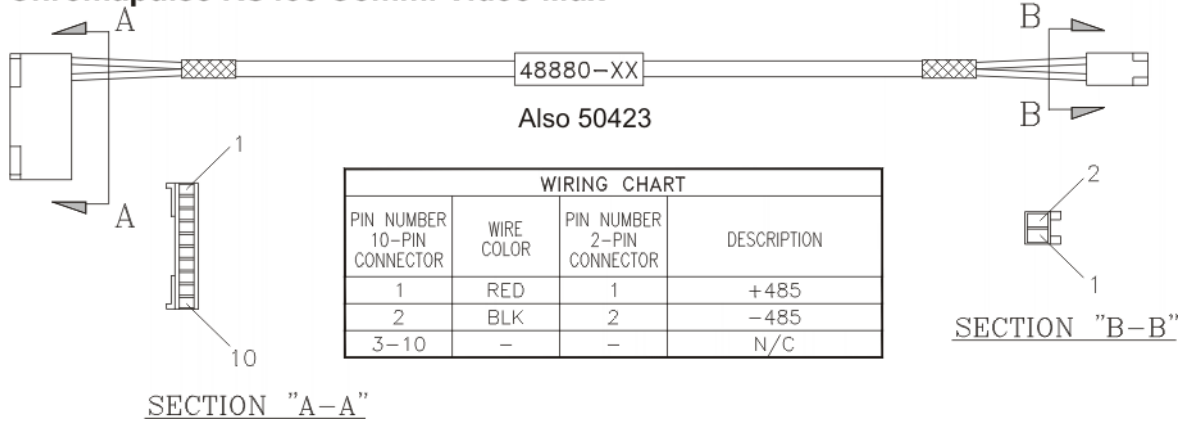

Chromapulse RS485 signal return

52015, 53662

Chromapulse RS485 Signal Return

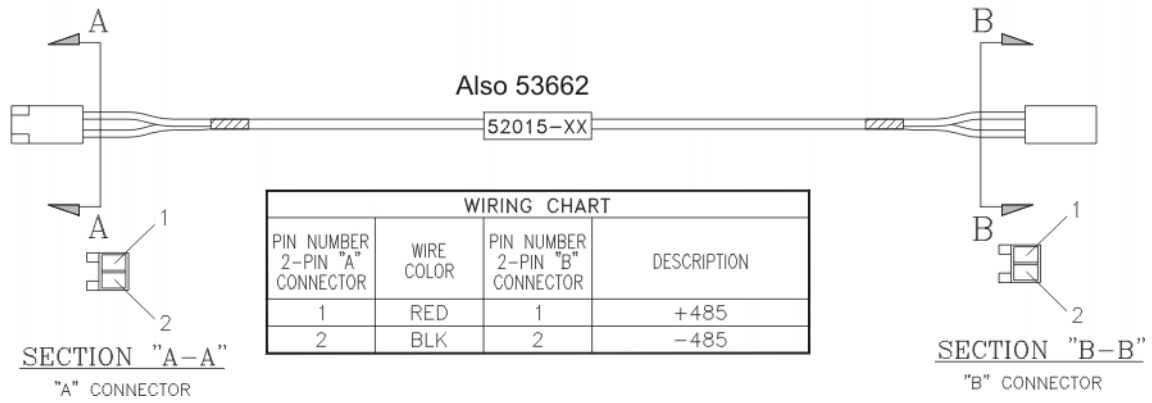

50428 BLOB umbilical #1

Umbilical #1 Intellispec Belvac Lighting & Optics Box

(Earlier version of umbilicals)

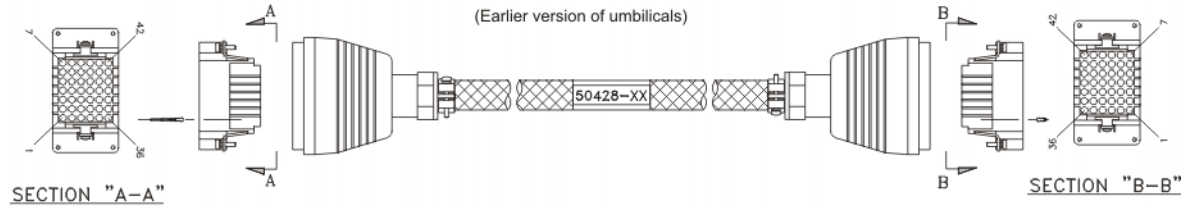

UMBILICAL PINOUT IS 1-1

ITEM 13-16AWG,10 COND.

WIRING CHART	
PIN NO.	DESCRIPTION
1	BLK
2	RED
3	ORG
4	YEL
5	BLU
8	BRN
9	RED/BLK
10	ORG/BLK
11	YEL/BLK
12	BLU/BLK

ITEM 13-16AWG,10 COND.

WIRING CHART	
PIN NO.	DESCRIPTION
6	BLK
7	RED
13	BRN
14	RED/BLK
15	ORG
16	YEL
17	BLU
22	ORG/BLK
23	YEL/BLK
24	BLU/BLK

ITEM 13-16AWG,10 COND.

WIRING CHART	
PIN NO.	DESCRIPTION
18	BLK
19	RED
20	ORG
21	YEL
25	BRN
26	RED/BLK
27	ORG/BLK
28	YEL/BLK
29	BLU
36	BLU/BLK

ITEM 6-16AWG,2 COND.

WIRING CHART	
PIN NO.	DESCRIPTION
30	RED
37	BLK

ITEM 15-18AWG, 4 COND.

WIRING CHART	
PIN NO.	DESCRIPTION
34	RED
35	BLK
41	WHT
42	GRN

50429 BLOB umbilical #2

Umbilical #2 Intellispec Belvac Lighting & Optics Box

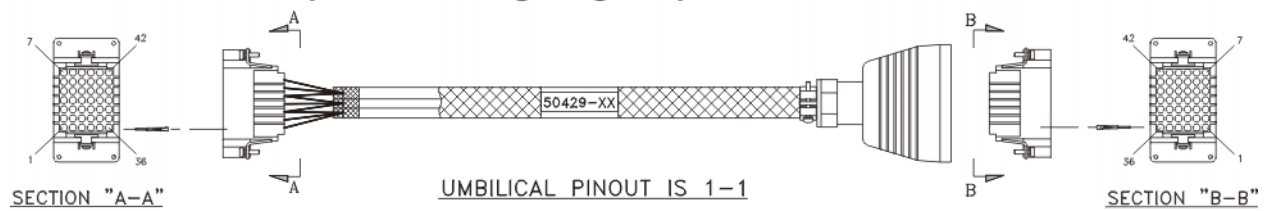

UMBILICAL PINOUT IS 1-1

ITEM 11-16AWG,10 COND.

WIRING CHART	
PIN NO.	DESCRIPTION
1	BLK
2	RED
3	ORG
4	YEL
5	BLU
8	BRN
9	RED/BLK
10	ORG/BLK
11	YEL/BLK
12	BLU/BLK

ITEM 11-16AWG,10 COND.

WIRING CHART	
PIN NO.	DESCRIPTION
6	BLK
7	RED
13	BRN
14	RED/BLK
15	ORG
16	YEL
17	BLU
22	ORG/BLK
23	YEL/BLK
24	BLU/BLK

ITEM 11-16AWG,10 COND.

WIRING CHART	
PIN NO.	DESCRIPTION
18	BLK
19	RED
20	ORG
21	YEL
25	BRN
26	RED/BLK
27	ORG/BLK
28	YEL/BLK
29	BLU
36	BLU/BLK

ITEM 5-16AWG,2 COND.

WIRING CHART	
PIN NO.	DESCRIPTION
30	RED
37	BLK

ITEM 13-18AWG, 4 COND.

WIRING CHART	
PIN NO.	DESCRIPTION
34	RED
35	BLK
41	WHT
42	GRN

51479 BLOB umbilical #1

Umbilical #1 Intellispec Belvac Lighting & Optics Box

(Newer version of umbilicals)

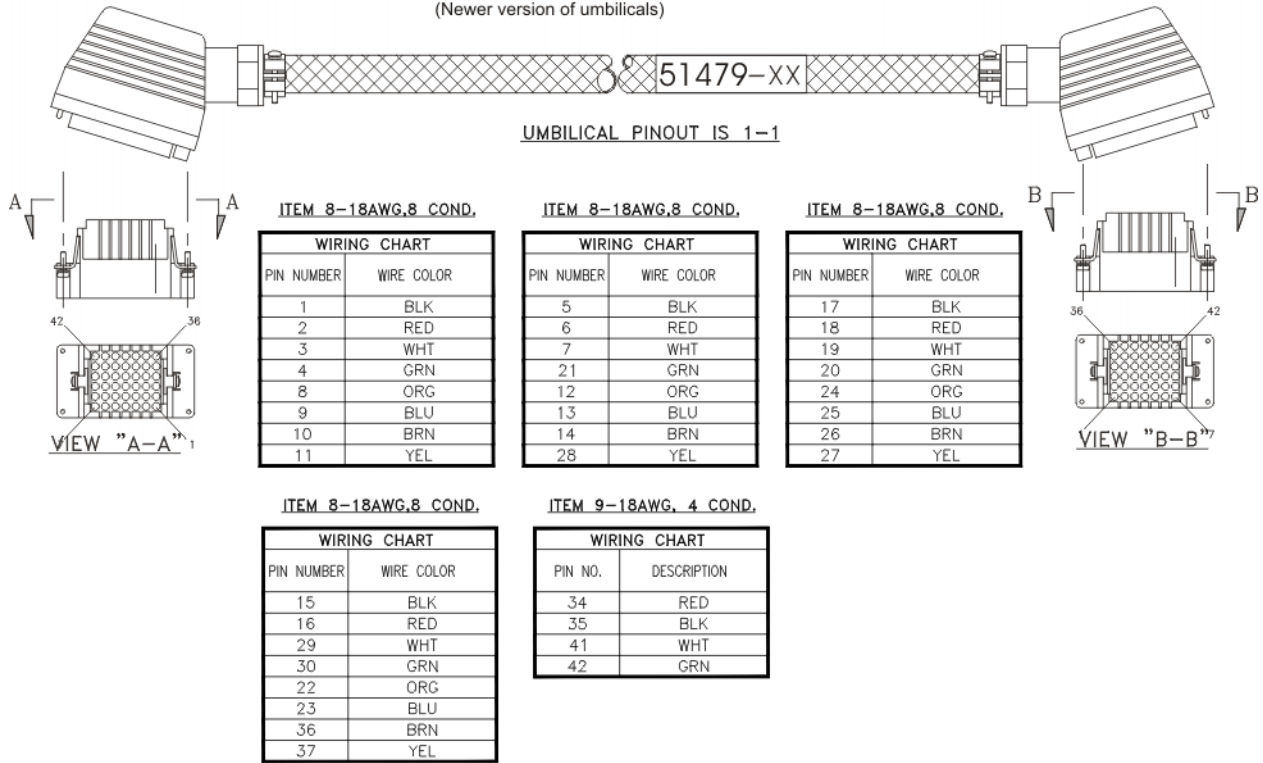

51509 BLOB umbilical #2

Umbilical #2 Intellispec Belvac Lighting & Optics Box

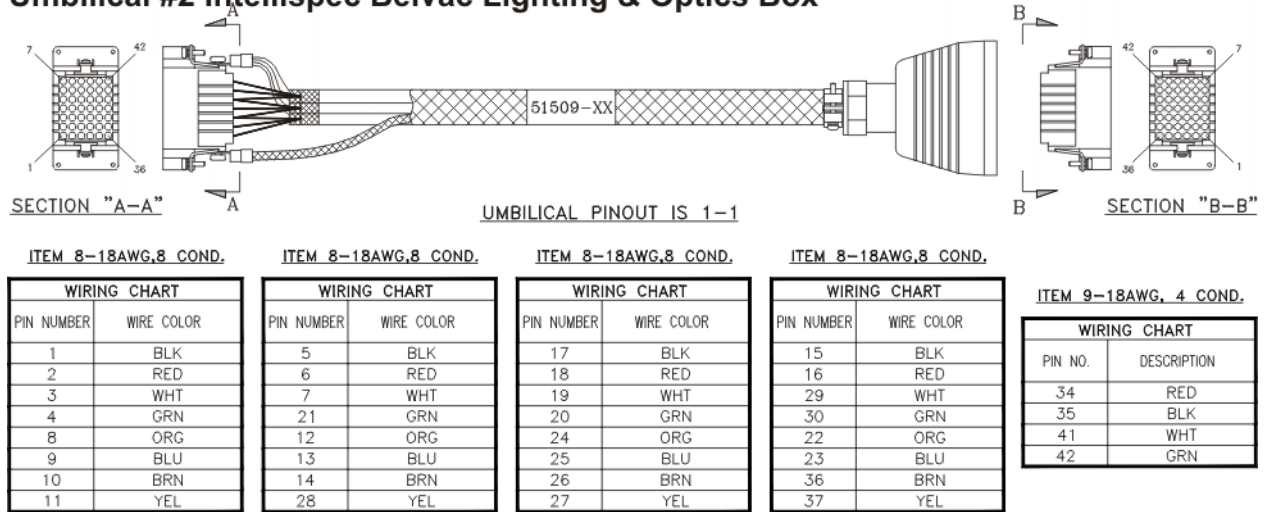

50430 body camera module

Camera Module Body Belvac

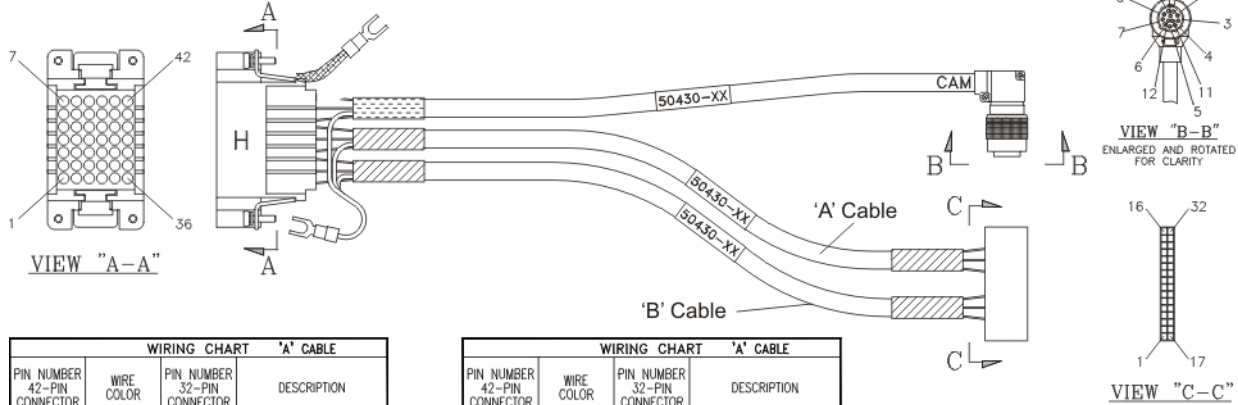

WIRING CHART 'A' CABLE			
PIN NUMBER 42-PIN CONNECTOR	WIRE COLOR	PIN NUMBER 32-PIN CONNECTOR	DESCRIPTION
1	RED	32	ZONE_1
2	WHT	31	ZONE_2
3	GRN	30	ZONE_3
4	BLU	29	ZONE_4
5	YEL	28	ZONE_5
6	BRN	27	ZONE_6
7	ORG	26	ZONE_7
15	WHT	25	ZONE_8
HARTING LUG	BRAID	PANEL LUG	SHIELD

WIRING CHART 'A' CABLE			
PIN NUMBER 42-PIN CONNECTOR	WIRE COLOR	PIN NUMBER 32-PIN CONNECTOR	DESCRIPTION
8	BLK	16	POWER
9	BLK	15	POWER
10	BLK	14	POWER
11	BLK	13	POWER
12	BLK	12	POWER
13	BLK	11	POWER
14	BLK	10	POWER
22	RED	9	POWER

Wiring Chart Camera Cable			
PIN NUMBER 42-PIN CONNECTOR	WIRE COLOR	PIN NUMBER 12-PIN CONNECTOR	DESCRIPTION
34	RED	2	+12V
35	BLK	1	COM
41	WHT	6	HSYNC
42	GRN	7	VSYNC

WIRING CHART 'B' CABLE			
PIN NUMBER 42-PIN CONNECTOR	WIRE COLOR	PIN NUMBER 32-PIN CONNECTOR	DESCRIPTION
16	RED	24	ZONE_9
17	WHT	23	ZONE_10
18	GRN	22	ZONE_11
19	BLU	21	ZONE_12
20	YEL	20	ZONE_13
21	BRN	19	ZONE_14
29	ORG	18	ZONE_15
30	WHT	17	ZONE_16
HARTING LUG	BRAID	PANEL LUG	SHIELD

WIRING CHART 'B' CABLE			
PIN NUMBER 42-PIN CONNECTOR	WIRE COLOR	PIN NUMBER 32-PIN CONNECTOR	DESCRIPTION
23	BLK	8	POWER
24	BLK	7	POWER
25	BLK	6	POWER
26	BLK	5	POWER
27	BLK	4	POWER
28	BLK	3	POWER
36	BLK	2	POWER
37	RED	1	POWER

53147 Body array control

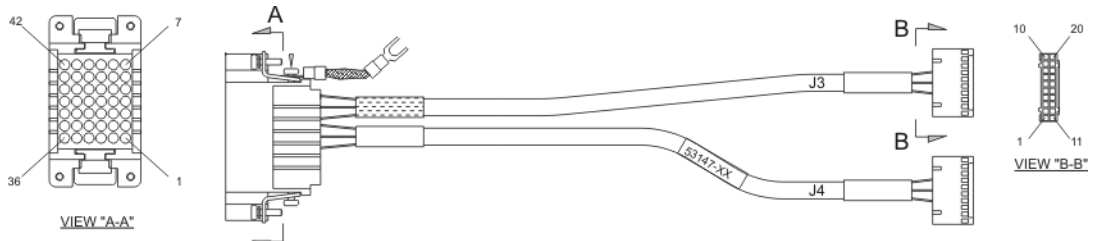

WIRING CHART CABLE 'J3'			
PIN NUMBER 42-PIN CONNECTOR	WIRE COLOR	PIN NUMBER 20-PIN CONNECTOR	DESCRIPTION
1	RED	2	ZONE_1
2	WHT	3	ZONE_2
3	GRN	4	ZONE_3
4	BLU	5	ZONE_4
5	YEL	6	ZONE_5
6	BRN	7	ZONE_6
7	ORG	8	ZONE_7
15	WHT	9	ZONE_8
GND1	BLK (ITEM2)	-	SHIELD

PART 1
PART 2
PART 3
PART 4
PART 5
PART 6
PART 7
PART 8

WIRING CHART CABLE 'J3'			
PIN NUMBER 42-PIN CONNECTOR	WIRE COLOR	PIN NUMBER 20-PIN CONNECTOR	DESCRIPTION
8	BLK	12	POWER
9	BLK	13	POWER
10	BLK	14	POWER
11	BLK	15	POWER
12	BLK	16	POWER
13	BLK	17	POWER
14	BLK	18	POWER
22	RED	19	POWER

WIRING CHART CABLE 'J4'			
PIN NUMBER 42-PIN CONNECTOR	WIRE COLOR	PIN NUMBER 20-PIN CONNECTOR	DESCRIPTION
16	RED	2	ZONE_9
17	WHT	3	ZONE_10
18	GRN	4	ZONE_11
19	BLU	5	ZONE_12
20	YEL	6	ZONE_13
21	BRN	7	ZONE_14
29	ORG	8	ZONE_15
30	WHT	9	ZONE_16
GND1	BLK (ITEM2)	-	SHIELD

PART 1
PART 2
PART 3
PART 4
PART 5
PART 6
PART 7
PART 8

WIRING CHART CABLE 'J4'			
PIN NUMBER 42-PIN CONNECTOR	WIRE COLOR	PIN NUMBER 20-PIN CONNECTOR	DESCRIPTION
23	BLK	12	POWER
24	BLK	13	POWER
25	BLK	14	POWER
26	BLK	15	POWER
27	BLK	16	POWER
28	BLK	17	POWER
36	BLK	18	POWER
37	RED	19	POWER

58189 digital camera control BLOB

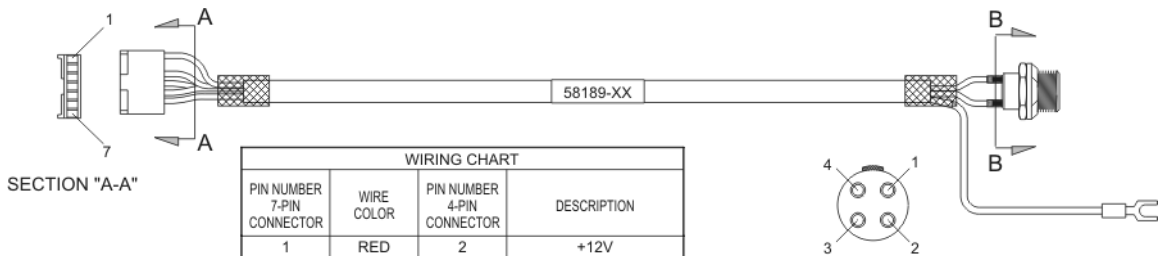

SECTION "A-A"

WIRING CHART			
PIN NUMBER 7-PIN CONNECTOR	WIRE COLOR	PIN NUMBER 4-PIN CONNECTOR	DESCRIPTION
1	RED	2	+12V
3	BLK	1*	GND
3	WHT	3*	TRIGGER -
6	GRN	4	TRIGGER +
4	BLK	-	SHIELD-NOTE 3

SECTION "B-B"

*2 WIRES CRIMPED IN 1 PIN

50528 array/ camera control

Array/ Camera Control Belvac

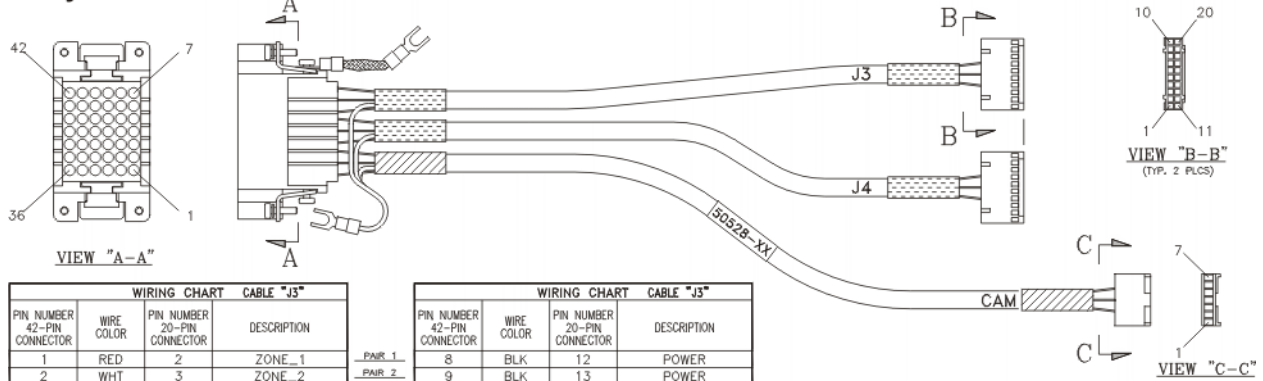

VIEW "A-A"

WIRING CHART CABLE "J3"			
PIN NUMBER 42-PIN CONNECTOR	WIRE COLOR	PIN NUMBER 20-PIN CONNECTOR	DESCRIPTION
1	RED	2	ZONE_1
2	WHT	3	ZONE_2
3	GRN	4	ZONE_3
4	BLU	5	ZONE_4
5	YEL	6	ZONE_5
6	BRN	7	ZONE_6
7	ORG	8	ZONE_7
15	WHT	9	ZONE_8
GND1	BLK (ITEM2)	-	SHIELD

WIRING CHART CABLE "J3"			
PIN NUMBER 42-PIN CONNECTOR	WIRE COLOR	PIN NUMBER 20-PIN CONNECTOR	DESCRIPTION
8	BLK	12	POWER
9	BLK	13	POWER
10	BLK	14	POWER
11	BLK	15	POWER
12	BLK	16	POWER
13	BLK	17	POWER
14	BLK	18	POWER
22	RED	19	POWER

WIRING CHART CABLE "J4"			
PIN NUMBER 42-PIN CONNECTOR	WIRE COLOR	PIN NUMBER 20-PIN CONNECTOR	DESCRIPTION
16	RED	2	ZONE_9
17	WHT	3	ZONE_10
18	GRN	4	ZONE_11
19	BLU	5	ZONE_12
20	YEL	6	ZONE_13
21	BRN	7	ZONE_14
29	ORG	8	ZONE_15
30	WHT	9	ZONE_16
GND1	BLK (ITEM2)	-	SHIELD

WIRING CHART CABLE "J4"			
PIN NUMBER 42-PIN CONNECTOR	WIRE COLOR	PIN NUMBER 20-PIN CONNECTOR	DESCRIPTION
23	BLK	12	POWER
24	BLK	13	POWER
25	BLK	14	POWER
26	BLK	15	POWER
27	BLK	16	POWER
28	BLK	17	POWER
36	BLK	18	POWER
37	BLK	19	POWER

WIRING CHART			
PIN NUMBER	WIRE COLOR	PIN NUMBER 7-PIN "CAM" CONNECTOR	DESCRIPTION
34	RED	1	+12V
35	BLK	3	COM
41	WHT	5	HSYNC
42	GRN	6	VSYNC
LUG	BLK (ITEM2)	4	SHIELD

N/C ON 42-PIN CONNECTOR PINS 31, 32, 33, 38, 39, & 40.

50676 array/ camera control base ext. 2

Array/ Camera Control Base Ext2 Belvac

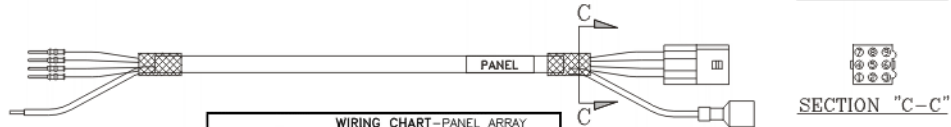
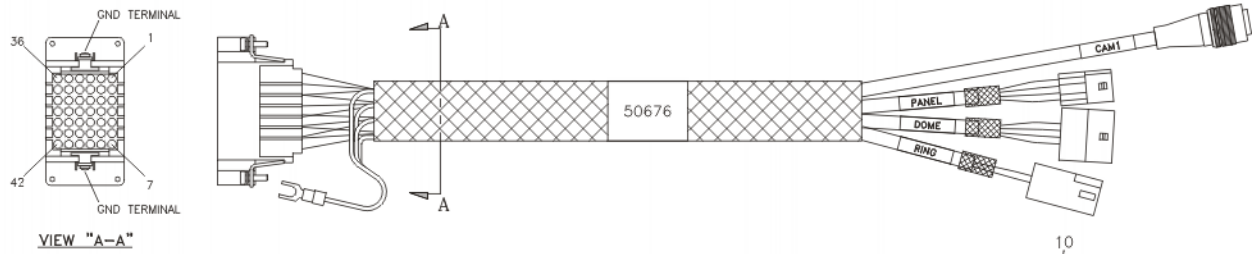

PIN NUMBER 42-PIN CONNECTOR	WIRE COLOR	PIN NUMBER 12-PIN CONNECTOR	DESCRIPTION
34	RED	2	+12V
35	BLK	1	COM
41	WHT	6	HSYNC
42	GRN	7	VSYSN

PIN NUMBER 42-PIN CONNECTOR	WIRE COLOR	PIN NUMBER 9-PIN CONNECTOR	DESCRIPTION
17	BLK	1	ZONE1
18	RED	2	ZONE2
19	WHT	3	ZONE3
20	GRN	4	ZONE4
23	ORG	5	POWER
24	BLU	6	POWER
25	BRN	7	POWER
26	YEL	8	POWER

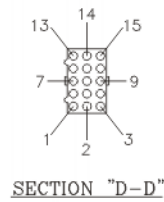

PIN NUMBER 42-PIN CONNECTOR	WIRE COLOR	PIN NUMBER 15-PIN CONNECTOR	DESCRIPTION
1	BLK	1	ZONE1
2	RED	2	ZONE2
3	WHT	3	ZONE3
4	GRN	4	ZONE4
5	ORG	5	ZONE5
6	BLU	6	ZONE6
7	BRN	7	ZONE7
8	YEL	10	POWER
9	VIO	11	POWER
10	GRY	12	POWER
11	PNK	13	POWER
12	TAN	14	POWER
13	RED/GRN	15	POWER
15	RED/YEL	8	ZONE8
16	RED/BLK	9	ZONE9

PIN NUMBER 42-PIN CONNECTOR	WIRE COLOR	PIN NUMBER 2-PIN CONNECTOR	DESCRIPTION
21	CLR	1	ZONE1
28	BLK	2	POWER

50431 camera control neck/ flange ext. 1

Camera Control Neck/ Flange Ext1 Belvac

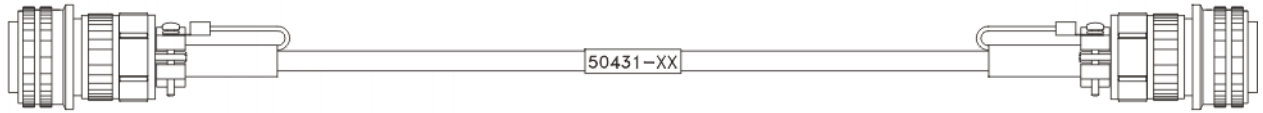

WIRING CHART			
PIN LETTER 19-PIN CONNECTOR	WIRE COLOR	PIN LETTER 19-PIN CONNECTOR	DESCRIPTION
A	BLK	A	COM
B	RED	B	+12V
C	WHT	C	HSYNC1
D	GRN	D	VSYNC1
E	BLU	E	COM
F	BRN	F	+12V
G	ORG	G	HSYNC2
H	YEL	H	VSYNC2

50674, 51453 array control neck/ flange ext. 1

Array Control Neck/ Flange Ext1 Belvac

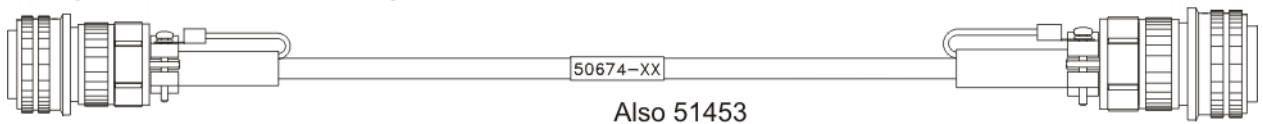

WIRING CHART		
PIN LETTER 5-PIN CONNECTOR	WIRE COLOR	PIN LETTER 10-PIN CONNECTOR
A	BLK	A
B	RED	B
C	WHT	C
D	GRN	D
E	BRN	E

50432 camera control neck/ flange ext. 2

Camera Control Neck/ Flange Ext2 Belvac

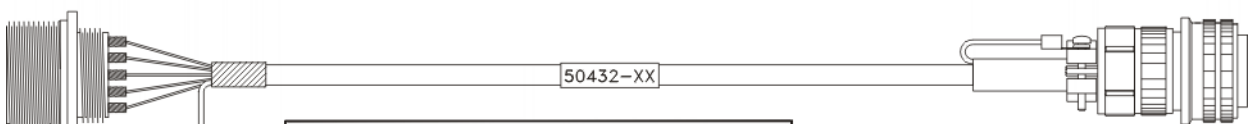

WIRING CHART			
PIN LETTER 19-PIN CONNECTOR	WIRE COLOR	PIN LETTER 19-PIN CONNECTOR	DESCRIPTION
A	BLK	A	COM
B	RED	B	+12V
C	WHT	C	HSYNC1
D	GRN	D	VSYNC1
E	BLU	E	COM
F	BRN	F	+12V
G	ORG	G	HSYNC2
H	YEL	H	VSYNC2

53811 neck/flange array control

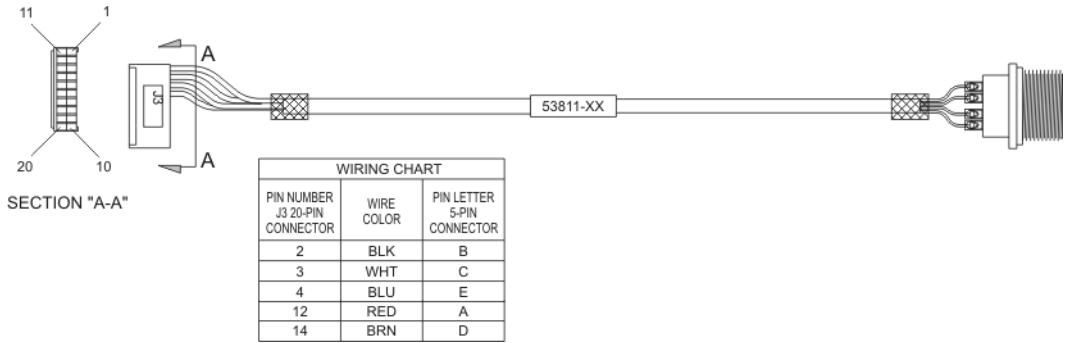

53814 reject

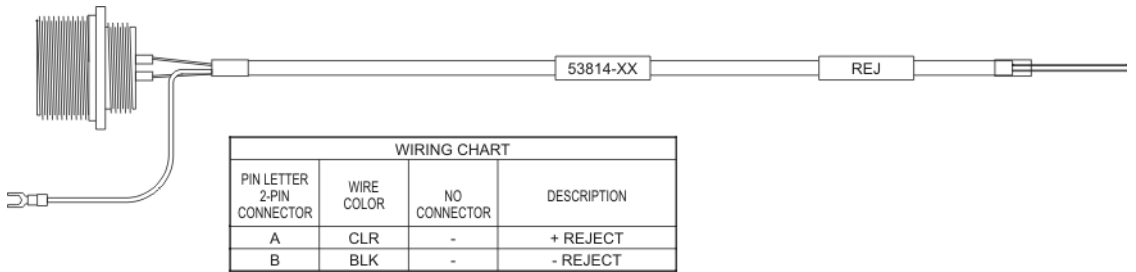

50675 array control neck/ flange ext. 2

Array Control Neck/ Flange Ext2 Belvac

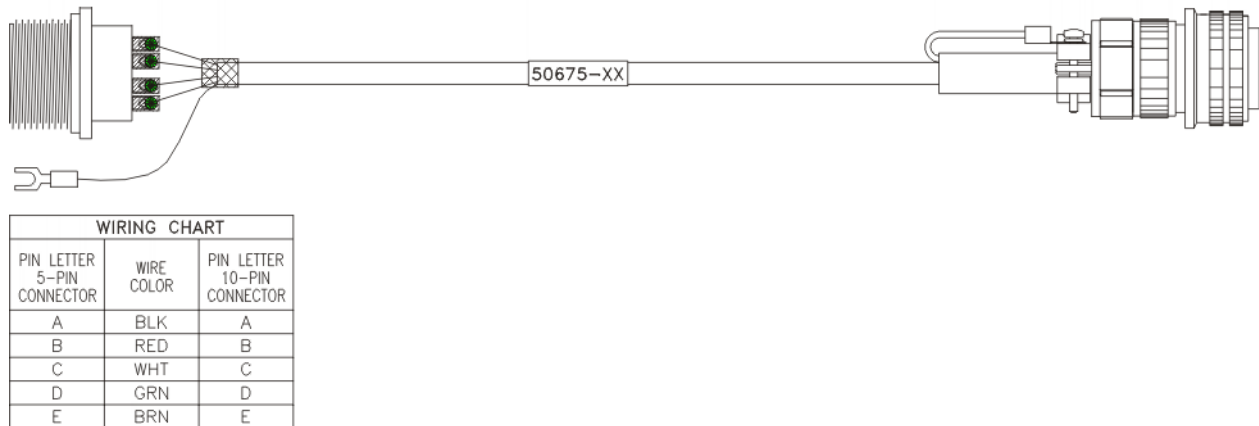

50435 encoder/ part detect/ reject inside BLOB

Encoder/ Part Detect/ Reject Belvac inside BLOB

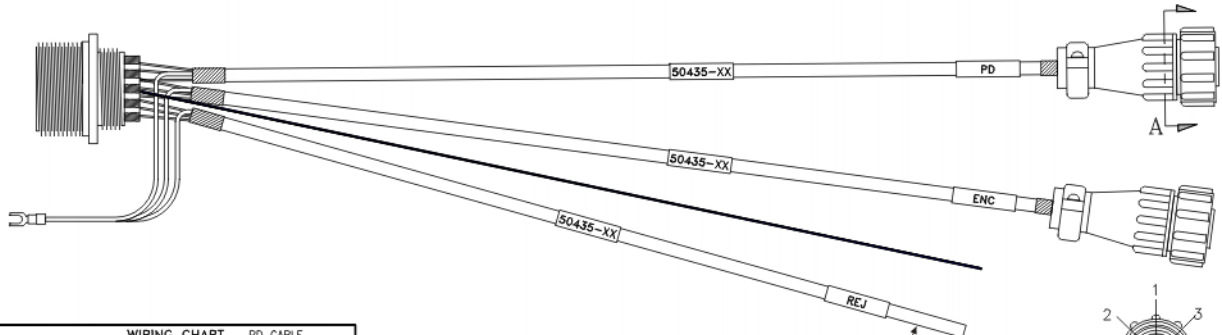

WIRING CHART PD CABLE			
PIN LETTER 10-PIN CONNECTOR	WIRE COLOR	PIN NUMBER PD CONNECTOR	DESCRIPTION
H	BLK	1	GND_ISOL
E	WHT	2	SIGNAL

TERMINATE AT "RM" TERMINAL STRIP (IN THE BLOB). APPLY NO HEAT SHRINK TUBE.

WIRING CHART REJECT CABLE			
PIN LETTER 10-PIN CONNECTOR	WIRE COLOR	PIN NUMBER REJECT CONNECTOR	DESCRIPTION
G	CLR	NOTE 6	24V_ISOL
C	BLK	NOTE 6	SIGNAL

WIRING CHART ENCODER CABLE			
PIN LETTER 10-PIN CONNECTOR	WIRE COLOR	PIN NUMBER ENCODER CONNECTOR	DESCRIPTION
A	RED	3	24V_ISOL
B	BLK	1	GND_ISOL
D	WHT	2	SIGNAL

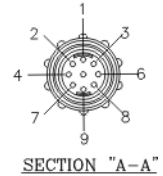

50436, 53659, 53812 encoder to PDX

Encoder to PDX Belvac

Also 53659
and 53812

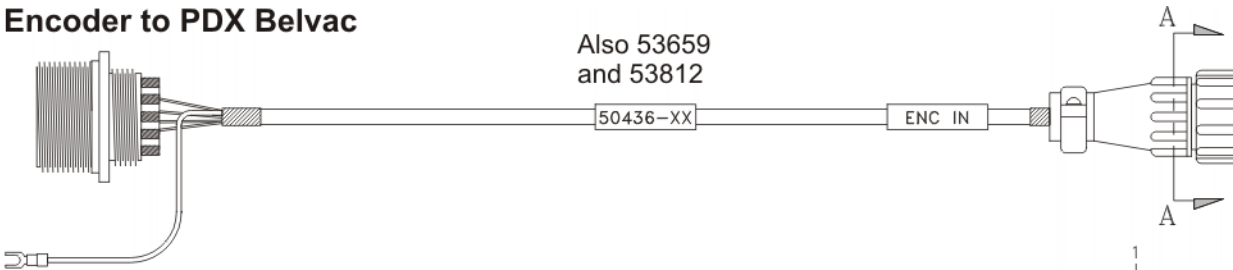

WIRING CHART			
PIN LETTER 10-PIN CONNECTOR	WIRE COLOR	PIN NUMBER ENCODER IN CONNECTOR	DESCRIPTION
A	WHT	2	PHS A
B	GRN	3	PHS B
C	BRN	4	PHS Z
D	RED	6	24V_ISOL
E	-	N/C	-
F	BLK	1	GND_ISOL

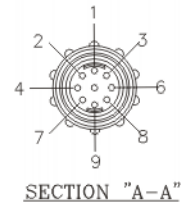

50437 encoder external

Encoder External Belvac



WIRING CHART			
PIN LETTER 10-PIN CONNECTOR	WIRE COLOR	PIN LETTER 10-PIN CONNECTOR	DESCRIPTION
A	WHT	A	PHS_A
B	GRN	B	PHS_B
C	BRN	C	PHS_Z
D	RED	D	24V_ISOL
E	BLU	E	SPARE
F	BLK	F	GND_ISOL
G - K	-	N/C	-

50434 encoder/ part detect/ reject

Encoder/ Part Detect/ Reject Belvac

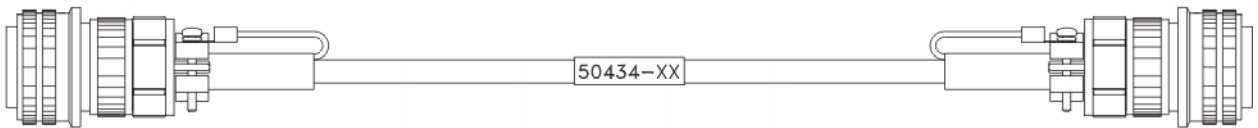

WIRING CHART			
PIN LETTER 6-PIN CONNECTOR	WIRE COLOR	PIN LETTER 10-PIN CONNECTOR	DESCRIPTION
A	RED	A,G*	24V_ISOL
B	BLK	B,H,K*	GND_ISOL
C	WHT	C	REJ
D	GRN	D	ENC
E	BRN	E	PD
F	BLU	F	REJ_CNFM

* NOTES:
JUMPER PIN A TO PIN G.
JUMPER PINS B,H AND K.

50439, 50627, 53667 reject solenoid

Reject Solenoid Belvac

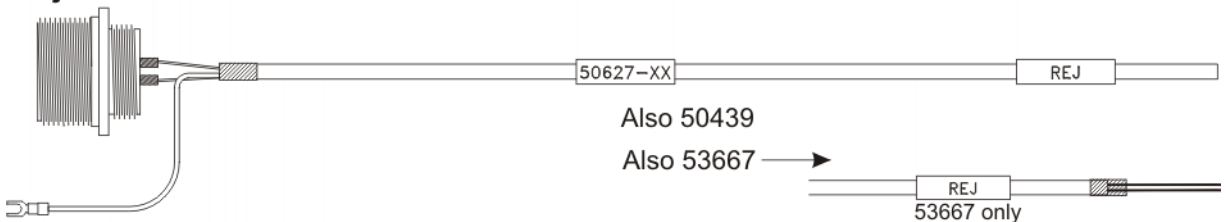

WIRING CHART			
PIN LETTER 2-PIN CONNECTOR	WIRE COLOR	NO CONNECTOR	DESCRIPTION
A	CLR		+REJECT
B	BLK		-REJECT

50626, 51451 reject external

Reject External Belvac

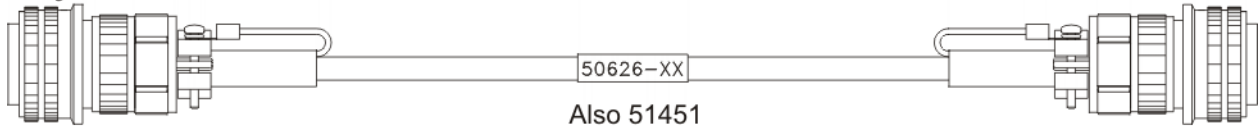

WIRING CHART			
PIN LETTER 2-PIN CONNECTOR	WIRE COLOR	PIN LETTER 2-PIN CONNECTOR	DESCRIPTION
A	CLR	A	+REJECT
B	BLK	B	-REJECT

50438, 51450 encoder BEI H25

Encoder BEI H25 Belvac

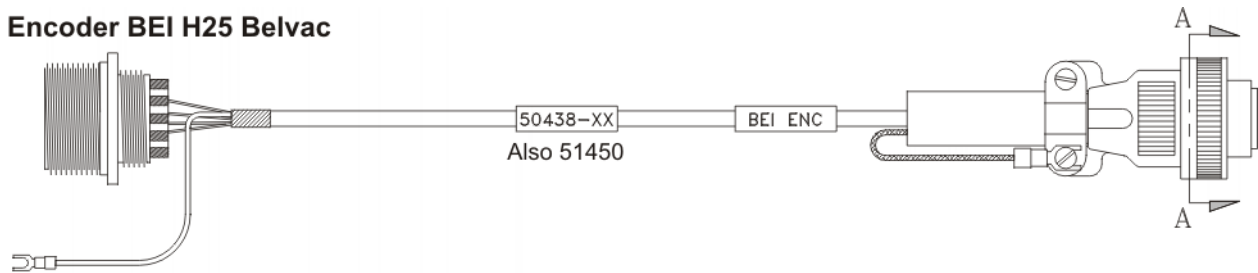

WIRING CHART			
PIN LETTER 10-PIN CONNECTOR	WIRE COLOR	PIN NUMBER BEI H25 CONNECTOR	DESCRIPTION
A	WHT	A	PHS A
B	GRN	B	PHS B
C	BRN	C	PHS Z
D	RED	D	24V_ISOL
E	-	N/C	-
F	BLK	F	GND_ISOL

50505 PDX expansion

PDX Expansion Belvac

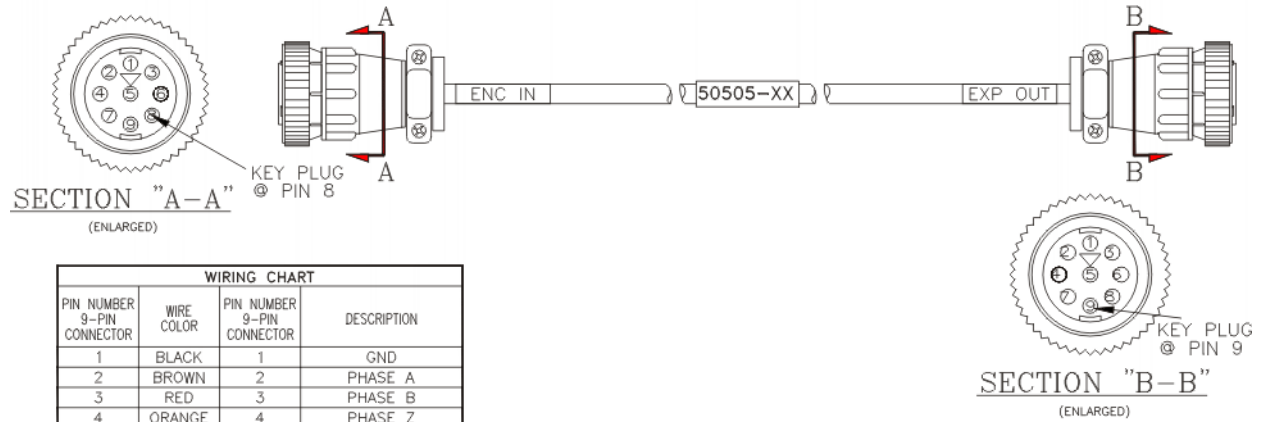

WIRING CHART			
PIN NUMBER 9-PIN CONNECTOR	WIRE COLOR	PIN NUMBER 9-PIN CONNECTOR	DESCRIPTION
1	BLACK	1	GND
2	BROWN	2	PHASE A
3	RED	3	PHASE B
4	ORANGE	4	PHASE Z
5	YELLOW	5	LED DRV
6	GREEN	6	PWR
7	BLUE	7	PWR
8	-	-	KEY PLUG
-	-	9	KEY PLUG

50866 encoder reject/ confirm

Encoder Reject/ Confirm Belvac

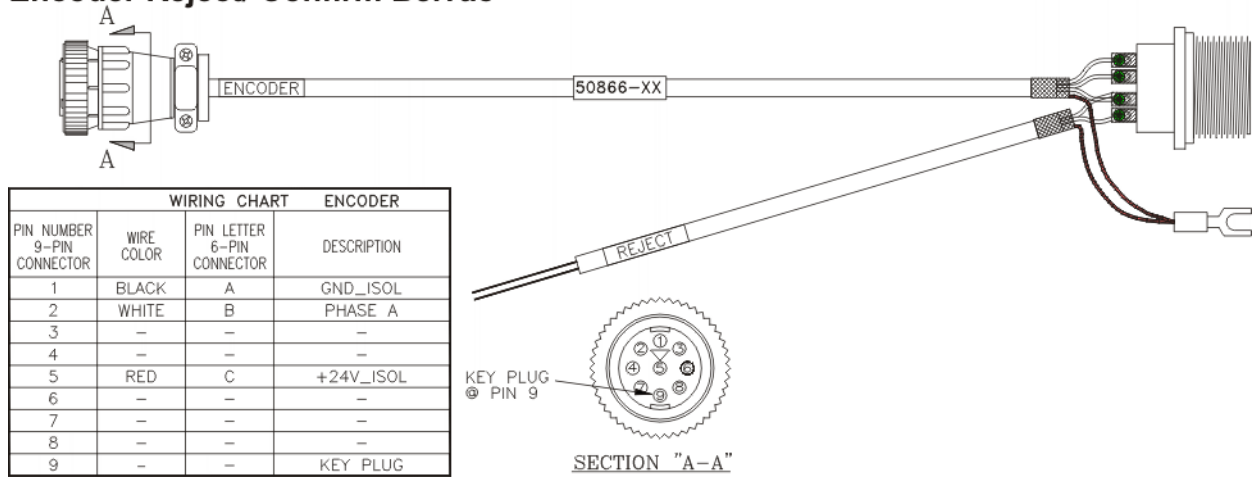

WIRING CHART			ENCODER
PIN NUMBER 9-PIN CONNECTOR	WIRE COLOR	PIN LETTER 6-PIN CONNECTOR	DESCRIPTION
1	BLACK	A	GND_ISOL
2	WHITE	B	PHASE A
3	-	-	-
4	-	-	-
5	RED	C	+24V_ISOL
6	-	-	-
7	-	-	-
8	-	-	-
9	-	-	KEY PLUG

WIRING CHART			REJECT
NO CONNECTOR	WIRE COLOR	PIN LETTER 6-PIN CONNECTOR	DESCRIPTION
-	BLACK	D	GND_ISOL
-	CLEAR	E	REJECT

50539, 53813 Chromapulse LED signal

Chromapulse LED Signal Belvac

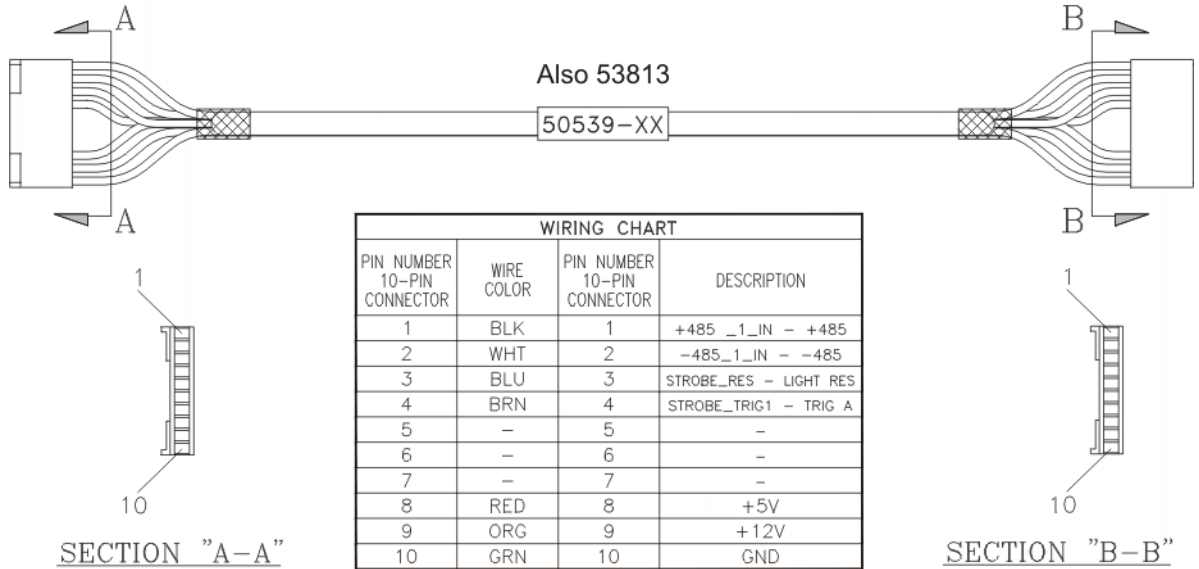

50540 RS485 signal return

RS485 Signal Return Belvac

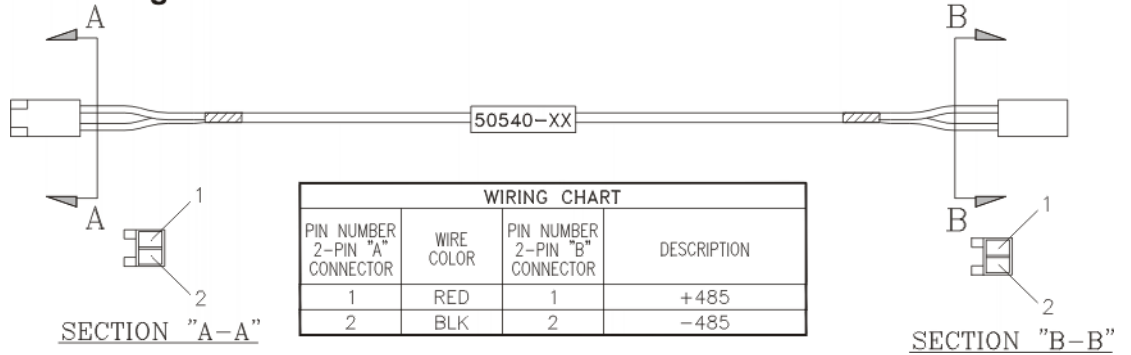

50541 power cable video mux
Power Cable Video Mux Belvac

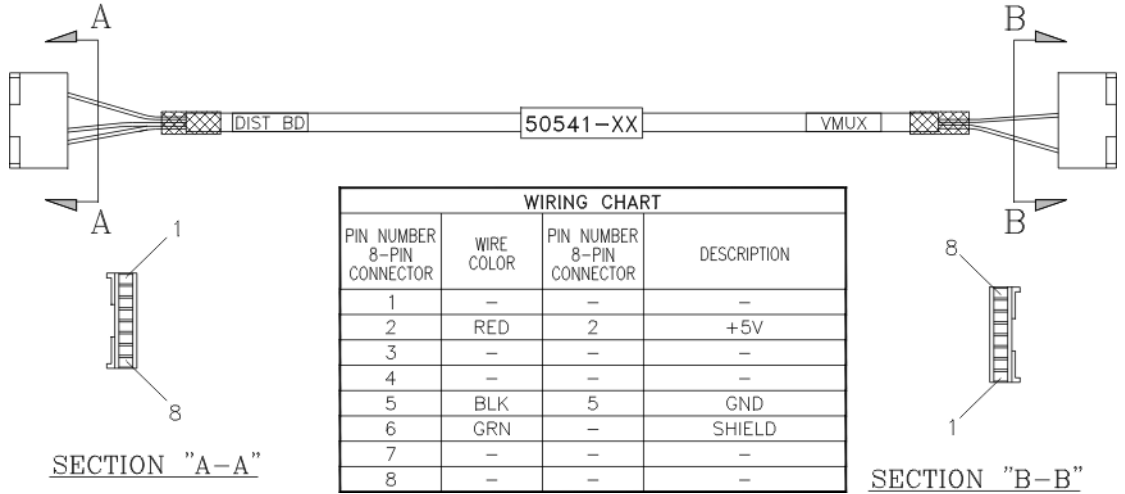

50542, 53663 camera control video mux
Camera Control Video Mux Belvac

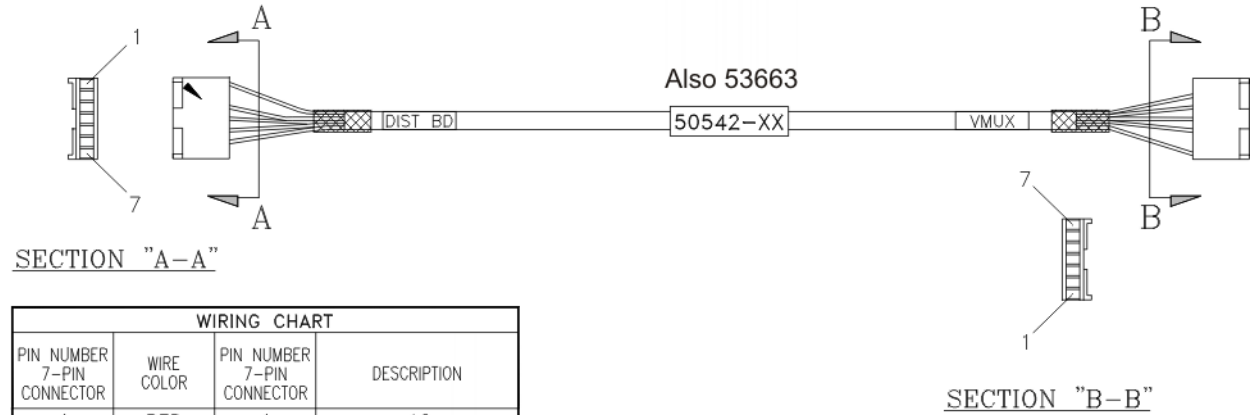

SOLDER BLACK WIRE, TO SHIELD. DIST BD END ONLY.

50543 RS485 communication video mux

RS485 Communication Video Mux Belvac

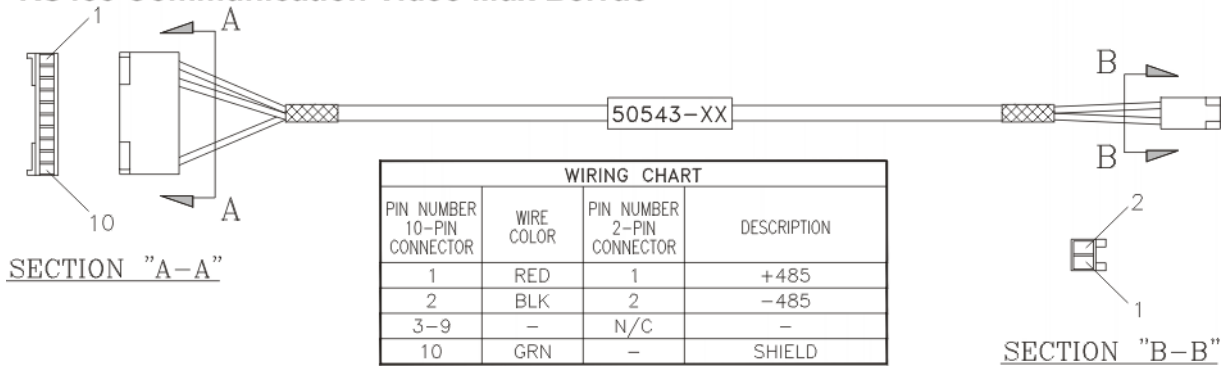

53666 encoder/ PDX/ reject small enclosure

Encoder/ PDX/ Reject Belvac sm. encl.

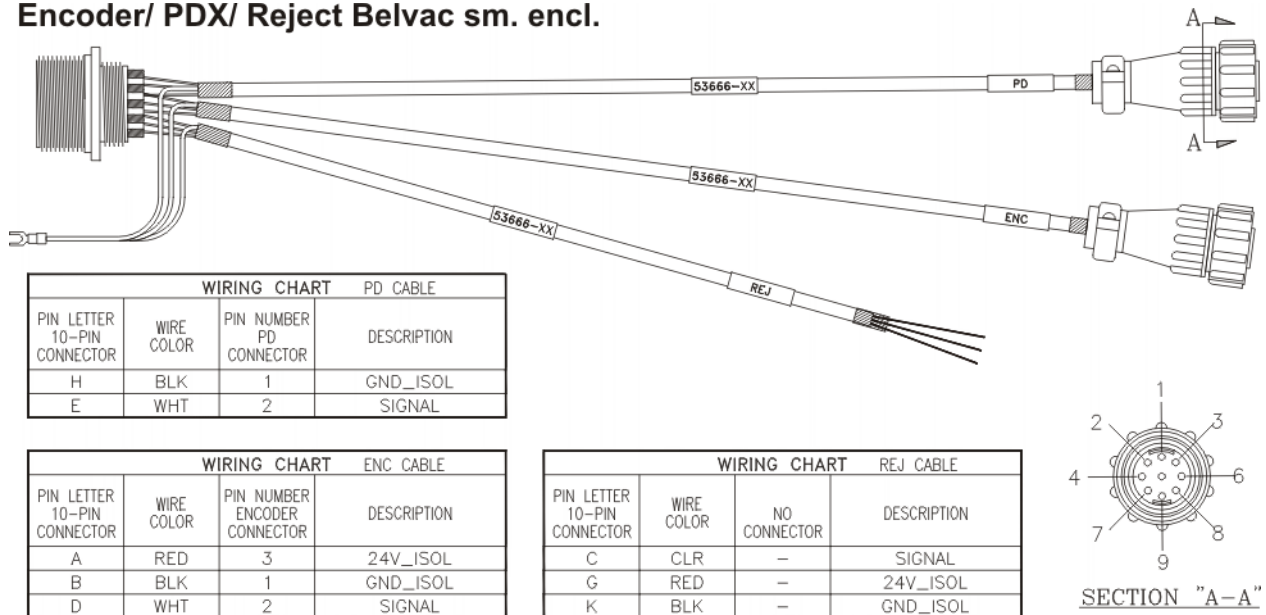

53150 cable body array CP4410

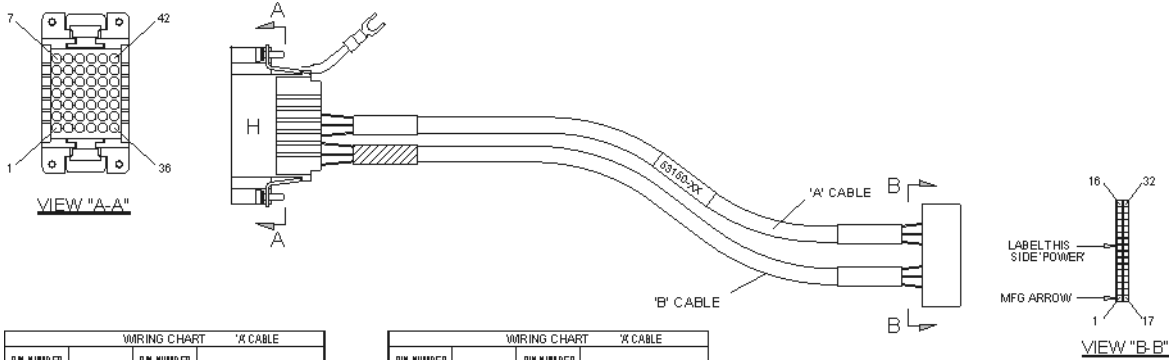

WIRING CHART 'A' CABLE			
PIN NUMBER 62-PIN CONNECTOR	WIRE COLOR	PIN NUMBER 32-PIN CONNECTOR	DESCRIPTION
1	RED	32	ZONE 1
2	WHT	31	ZONE 2
3	GRN	30	ZONE 3
4	BLU	29	ZONE 4
5	YEL	28	ZONE 5
6	BRN	27	ZONE 6
7	ORG	26	ZONE 7
15	WHT	25	ZONE 8

WIRING CHART 'A' CABLE				
PIN NUMBER 62-PIN CONNECTOR	WIRE COLOR	PIN NUMBER 32-PIN CONNECTOR	DESCRIPTION	
PAIR 1	8	BLK	16	POWER
PAIR 2	9	BLK	15	POWER
PAIR 3	10	BLK	14	POWER
PAIR 4	11	BLK	13	POWER
PAIR 5	12	BLK	12	POWER
PAIR 6	13	BLK	11	POWER
PAIR 7	14	BLK	10	POWER
PAIR 8	22	RED	9	POWER

WIRING CHART 'B' CABLE			
PIN NUMBER 62-PIN CONNECTOR	WIRE COLOR	PIN NUMBER 32-PIN CONNECTOR	DESCRIPTION
16	RED	24	ZONE 9
17	WHT	23	ZONE 10
18	GRN	22	ZONE 11
19	BLU	21	ZONE 12
20	YEL	20	ZONE 13
21	BRN	19	ZONE 14
29	ORG	18	ZONE 15
30	WHT	17	ZONE 16

WIRING CHART 'B' CABLE				
PIN NUMBER 62-PIN CONNECTOR	WIRE COLOR	PIN NUMBER 32-PIN CONNECTOR	DESCRIPTION	
PAIR 1	23	BLK	8	POWER
PAIR 2	24	BLK	7	POWER
PAIR 3	25	BLK	6	POWER
PAIR 4	26	BLK	5	POWER
PAIR 5	27	BLK	4	POWER
PAIR 6	28	BLK	3	POWER
PAIR 7	36	BLK	2	POWER
PAIR 8	37	RED	1	POWER

53148 body array control

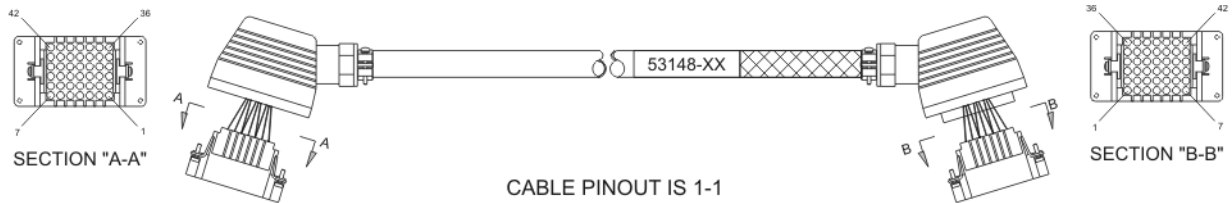

WIRING CHART	
PIN NUMBER	WIRE COLOR
1	BLK
2	RED
3	WHT
4	GRN
8	ORG
9	BLU
10	BRN
11	YEL

WIRING CHART	
PIN NUMBER	WIRE COLOR
5	BLK
6	RED
7	WHT
21	GRN
12	ORG
13	BLU
14	BRN
28	YEL

WIRING CHART	
PIN NUMBER	WIRE COLOR
17	BLK
18	RED
19	WHT
20	GRN
24	ORG
25	BLU
26	BRN
27	YEL

WIRING CHART	
PIN NUMBER	WIRE COLOR
15	BLK
16	RED
29	WHT
30	GRN
22	ORG
23	BLU
36	BRN
37	YEL

58186 digital camera control BLOB to gland plate

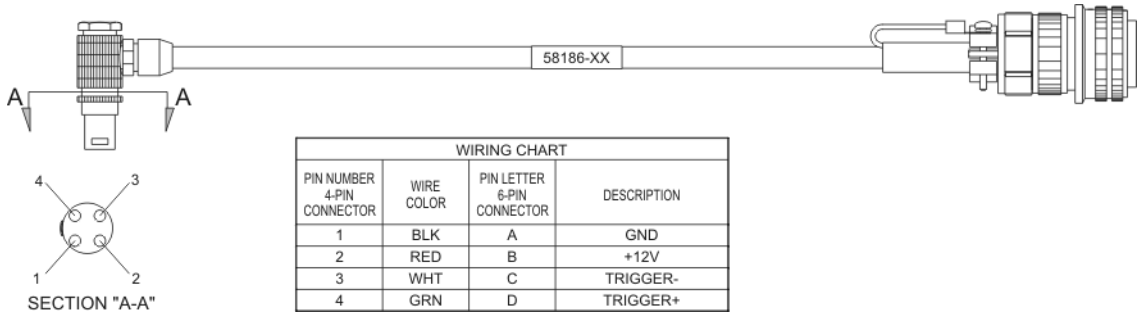

58184 digital camera control gland plate to camera

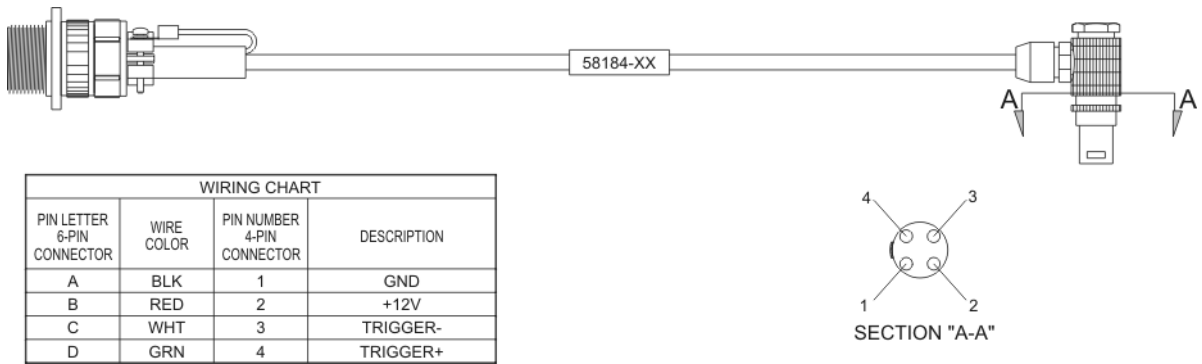

53149 body array ext. 2

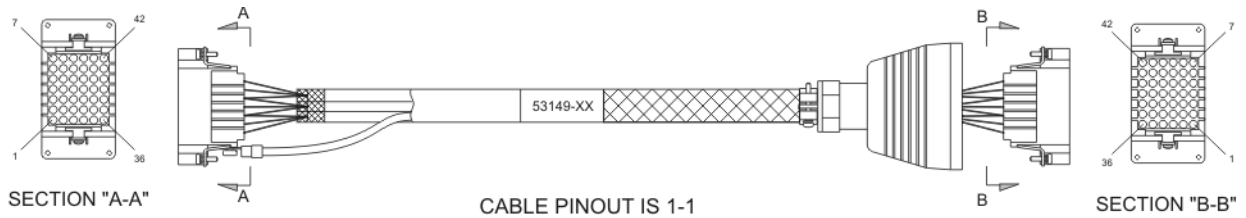

WIRING CHART	
PIN NUMBER	WIRE COLOR
1	BLK
2	RED
3	WHT
4	GRN
8	ORG
9	BLU
10	BRN
11	YEL

WIRING CHART	
PIN NUMBER	WIRE COLOR
5	BLK
6	RED
7	WHT
21	GRN
12	ORG
13	BLU
14	BRN
28	YEL

WIRING CHART	
PIN NUMBER	WIRE COLOR
17	BLK
18	RED
19	WHT
20	GRN
24	ORG
25	BLU
26	BRN
27	YEL

WIRING CHART	
PIN NUMBER	WIRE COLOR
15	BLK
16	RED
29	WHT
30	GRN
22	ORG
23	BLU
36	BRN
37	YEL

51454 array control neck/flange ext. 2



WIRING CHART		
PIN LETTER 5-PIN CONNECTOR	WIRE COLOR	PIN LETTER 5-PIN CONNECTOR
A	BLK	A
B	RED	B
C	WHT	C
D	GRN	D
E	BRN	E

51452 reject solenoid

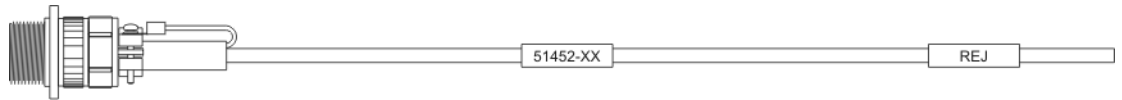

WIRING CHART			
PIN LETTER 2-PIN CONNECTOR	WIRE COLOR	NO CONNECTOR	DESCRIPTION
A	CLR		+REJECT
B	BLK		-REJECT

58190 digital camera control CP4402/ CP4410 camera box

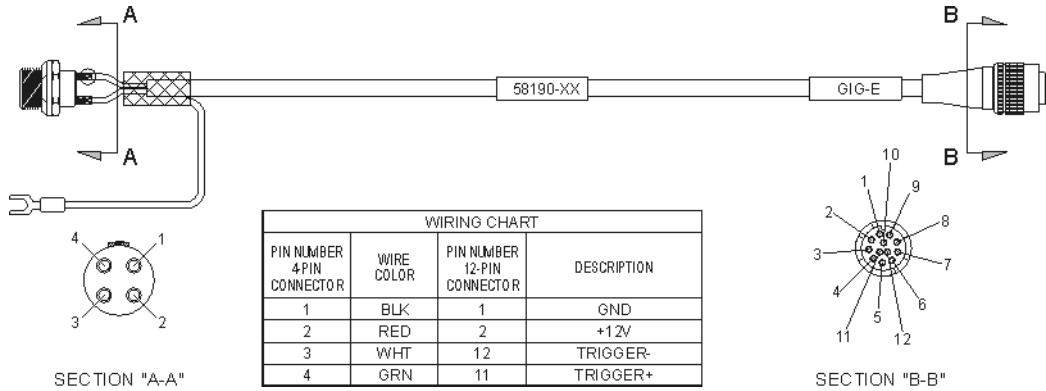

58188 Video CAT6 Belvac BLOB through gland plate

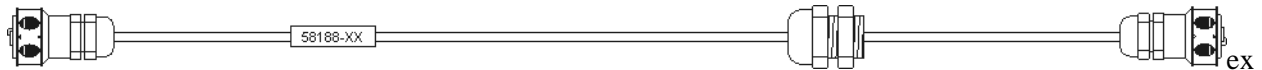

CPIC1 inspection module

48873 Chrompulse IC1 camera control

Chrompulse Camera Control for IC1

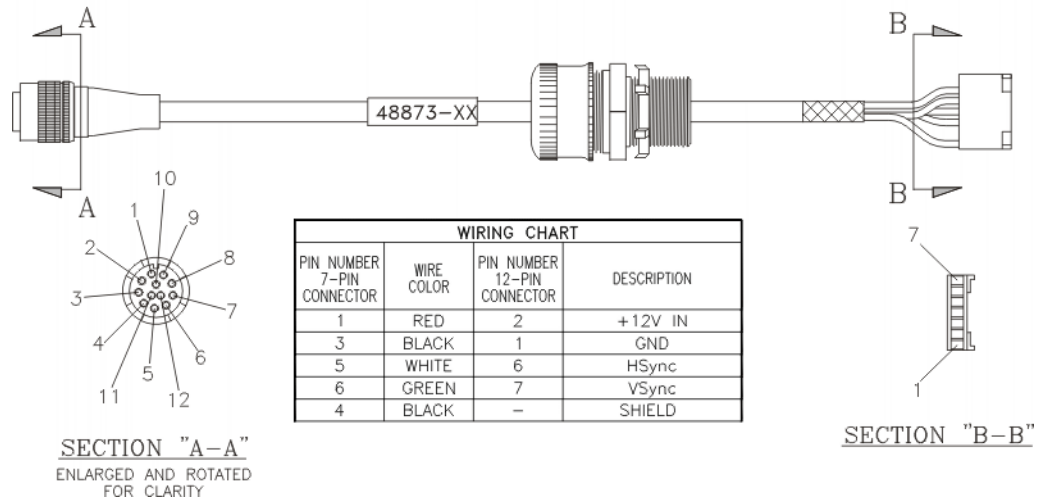

48878 Chrompulse power video mux

Chrompulse Power Video Mux

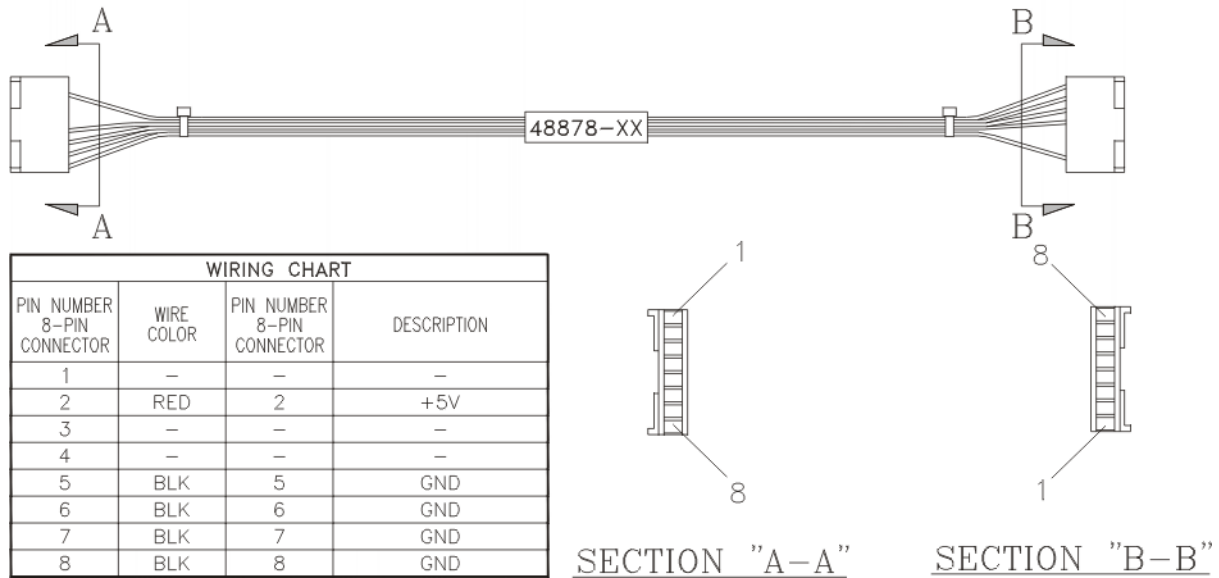

CP4410 inspection module

Umbilical control box RT6 CP4410

56015

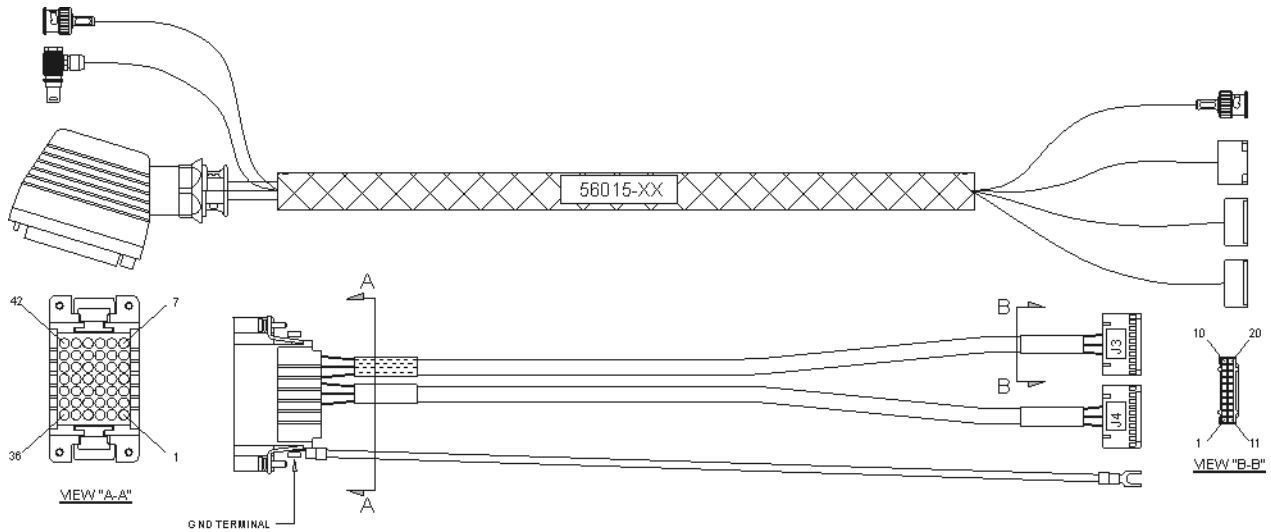

WIRING CHART			
PIN NUMBER 42-PIN CONNECTOR	WIRE COLOR	PIN NUMBER 20-PIN J3 CONNECTOR	DESCRIPTION
1	RED	2	ZONE_1
2	WHT	3	ZONE_2
3	GRN	4	ZONE_3
4	BLU	5	ZONE_4
5	YEL	6	ZONE_5
6	BRN	7	ZONE_6
7	ORG	8	ZONE_7
15	WHT	9	ZONE_8

WIRING CHART			
PIN NUMBER 42-PIN CONNECTOR	WIRE COLOR	PIN NUMBER 20-PIN J3 CONNECTOR	DESCRIPTION
PAIR 1			
8	BLK	12	POWER
PAIR 2			
9	BLK	13	POWER
PAIR 3			
10	BLK	14	POWER
PAIR 4			
11	BLK	15	POWER
PAIR 5			
12	BLK	16	POWER
PAIR 6			
13	BLK	17	POWER
PAIR 7			
14	BLK	18	POWER
PAIR 8			
22	RED	19	POWER

WIRING CHART			
PIN NUMBER 42-PIN CONNECTOR	WIRE COLOR	PIN NUMBER 20-PIN J4 CONNECTOR	DESCRIPTION
16	RED	2	ZONE_9
17	WHT	3	ZONE_10
18	GRN	4	ZONE_11
19	BLU	5	ZONE_12
20	YEL	6	ZONE_13
21	BRN	7	ZONE_14
29	ORG	8	ZONE_15
30	WHT	9	ZONE_16

WIRING CHART			
PIN NUMBER 42-PIN CONNECTOR	WIRE COLOR	PIN NUMBER 20-PIN J4 CONNECTOR	DESCRIPTION
PAIR 1			
23	BLK	12	POWER
PAIR 2			
24	BLK	13	POWER
PAIR 3			
25	BLK	14	POWER
PAIR 4			
26	BLK	15	POWER
PAIR 5			
27	BLK	16	POWER
PAIR 6			
28	BLK	17	POWER
PAIR 7			
36	BLK	18	POWER
PAIR 8			
37	RED	19	POWER

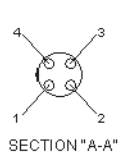
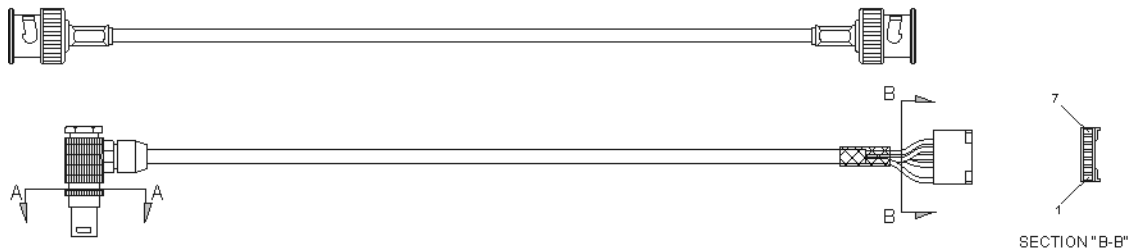

WIRING CHART			
PIN NUMBER 4-PIN CONNECTOR	WIRE COLOR	PIN NUMBER 7-PIN CONNECTOR	DESCRIPTION
1	BLACK	3	GND
2	RED	1	+12V
3	WHITE	5	H SYNC
4	GREEN	6	V SYNC
-	DRAIN	4	SHIELD

SECTION "B-B"

CP4410E inspection module

51215, 57484 Chromapulse camera control

Chromapulse Camera Control for CP4410E & PET

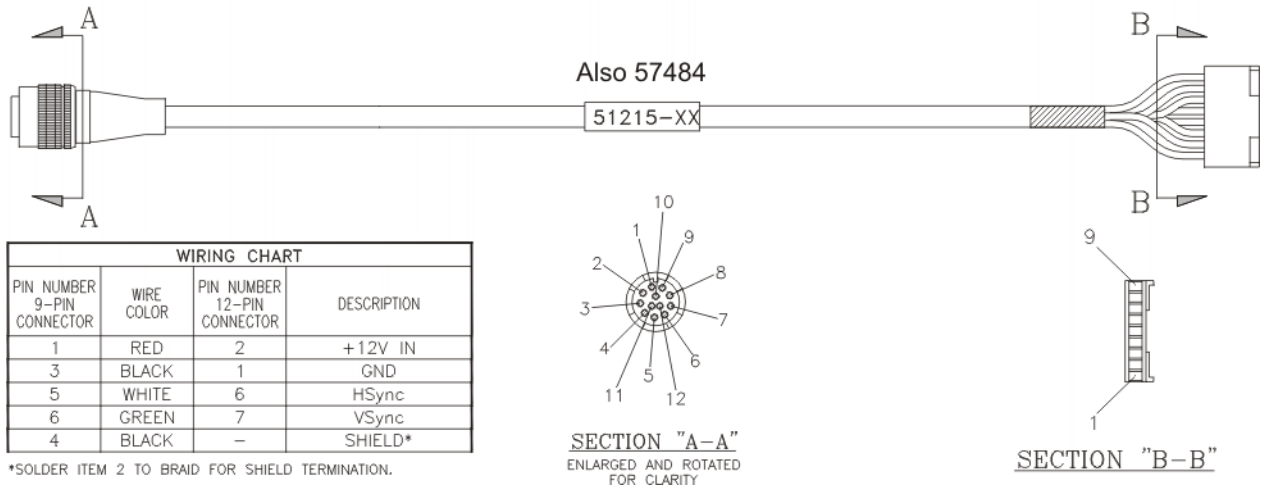

GIG-E camera control

56111

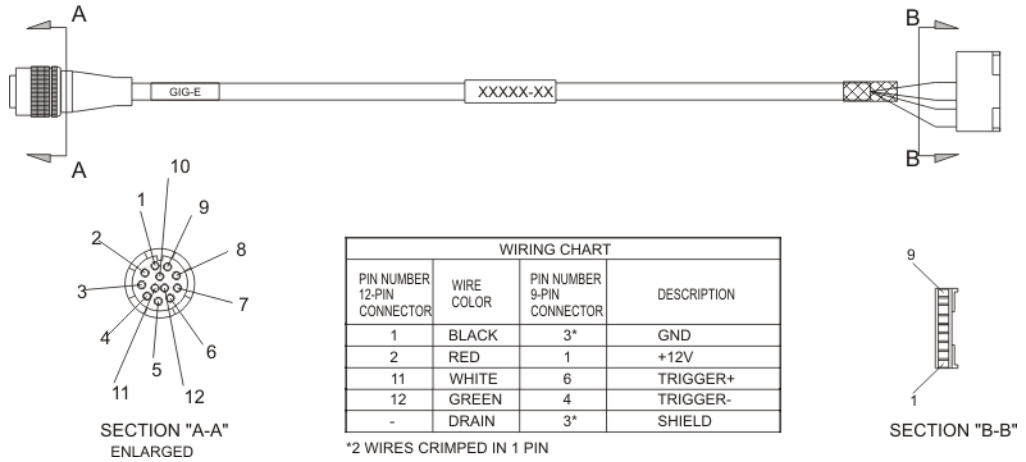

51217 Chromapulse LED power
Chromapulse LED power CP4410E

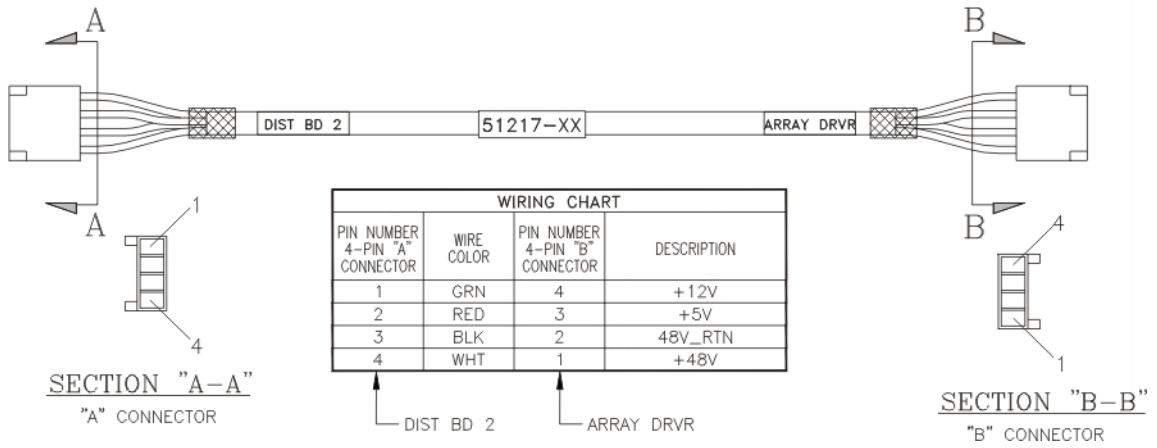

Chromapulse LED power
 50538, 52013, 53660, 53661
Chromapulse LED power

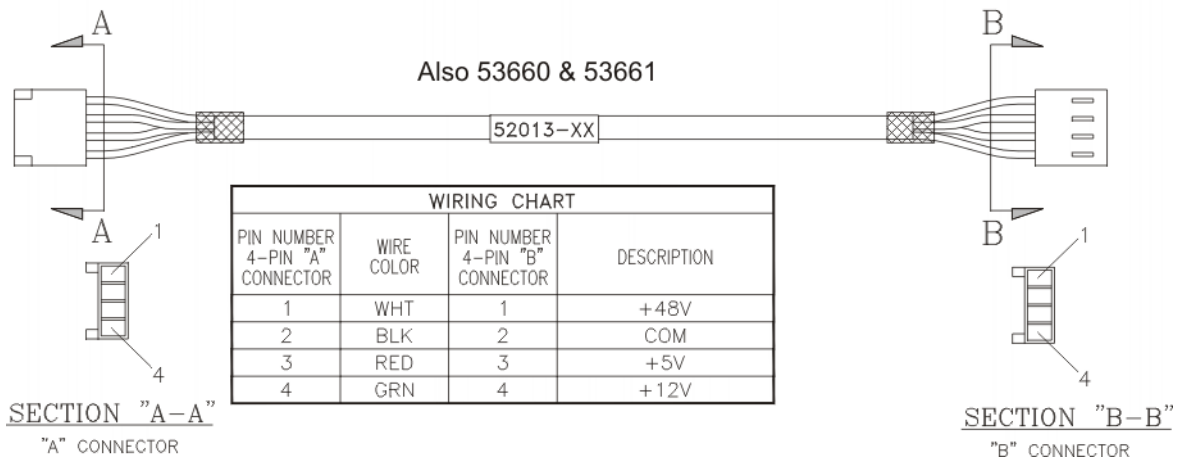

51218, 51048 Chromapulse array

Also 56841 CP4412E

Chromapulse Array CP4410E, CP4411, CP4412

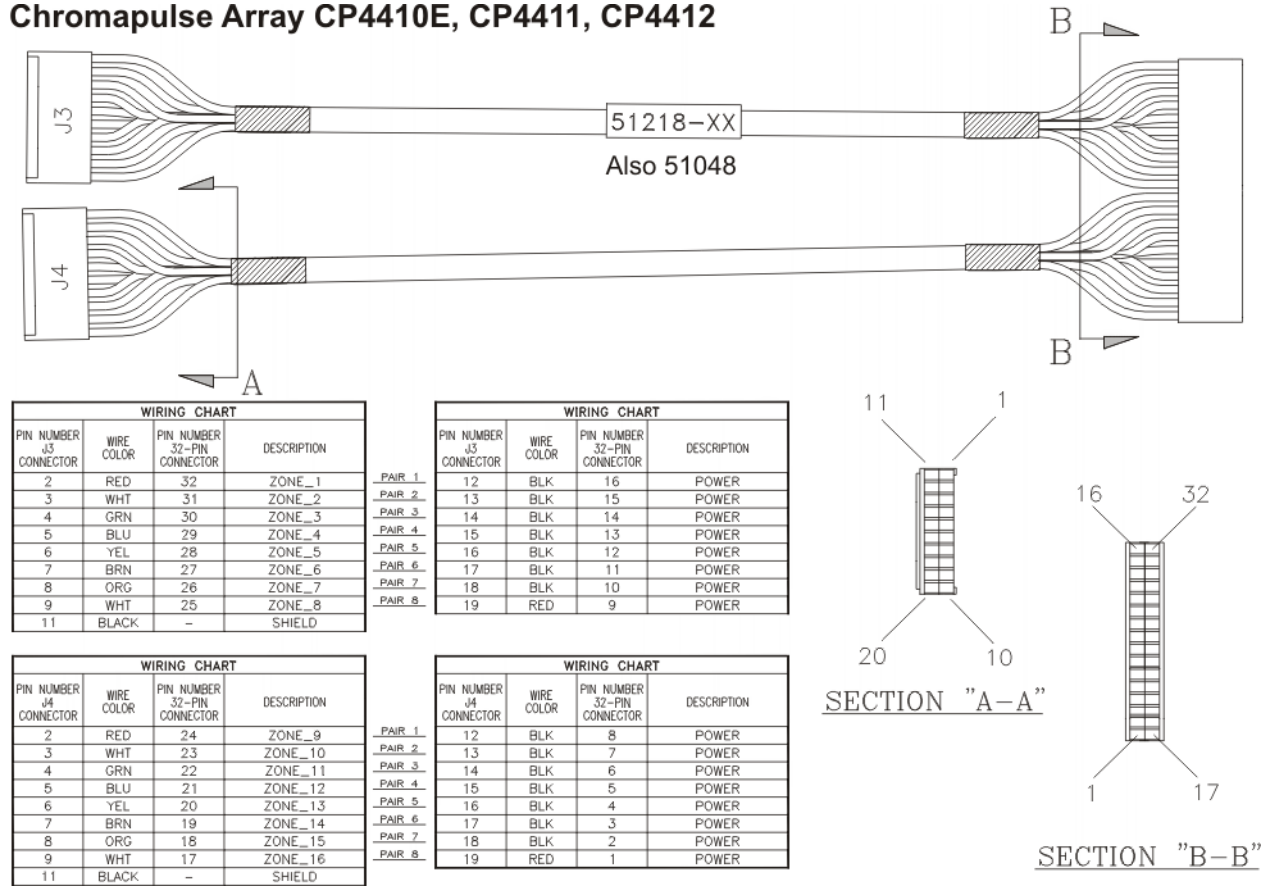

Chromapulse RS485 signal return

52015, 53662

Chromapulse RS485 Signal Return

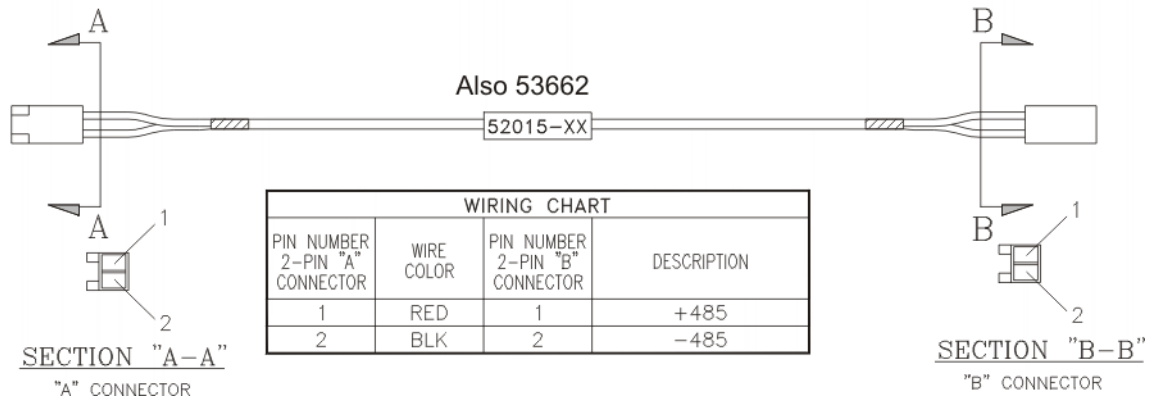

52019, 52017, 51645, 52024 Chromapulse camera control 90 degrees

Chromapulse Camera Control 90 degrees

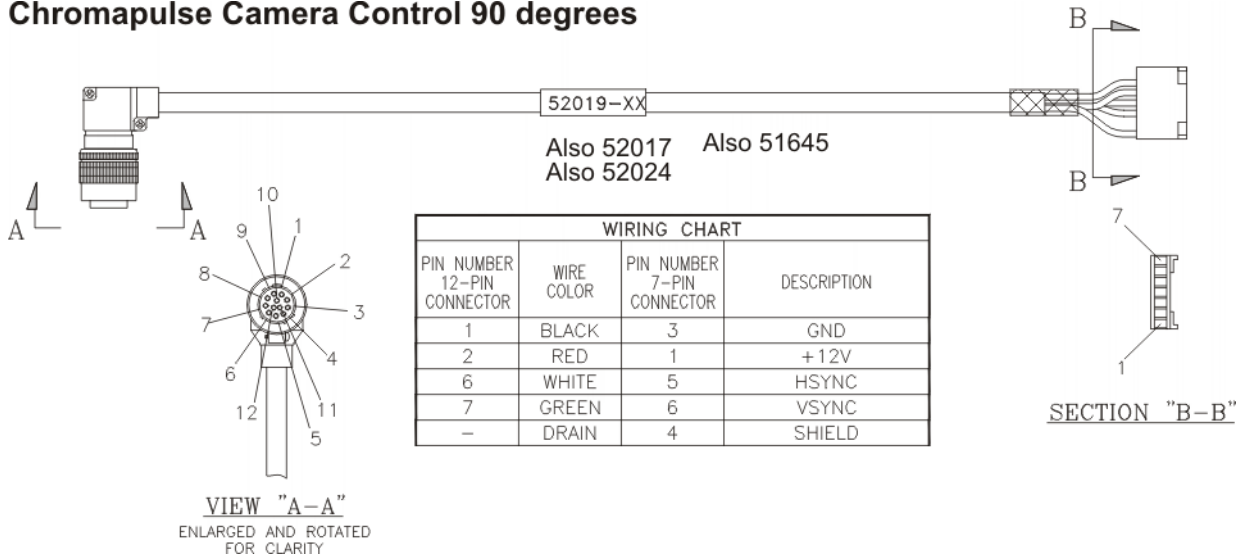

Chromapulse LED signal

51216, 52014

Chromapulse LED signal 4410E

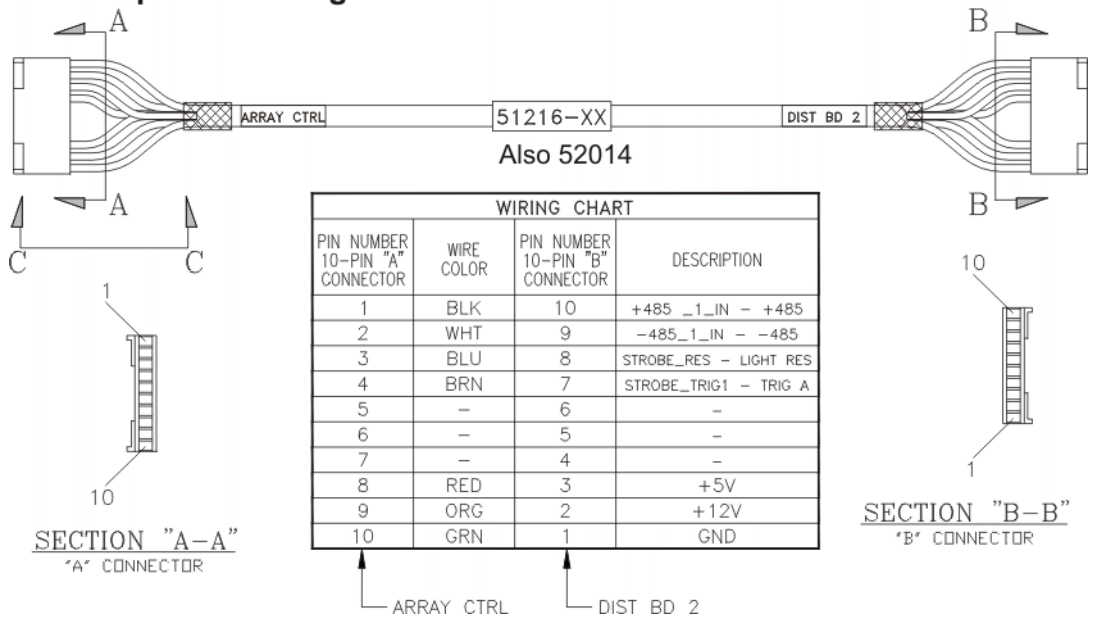

52016 Chromapulse body array

Chromapulse Body Array CP4410E

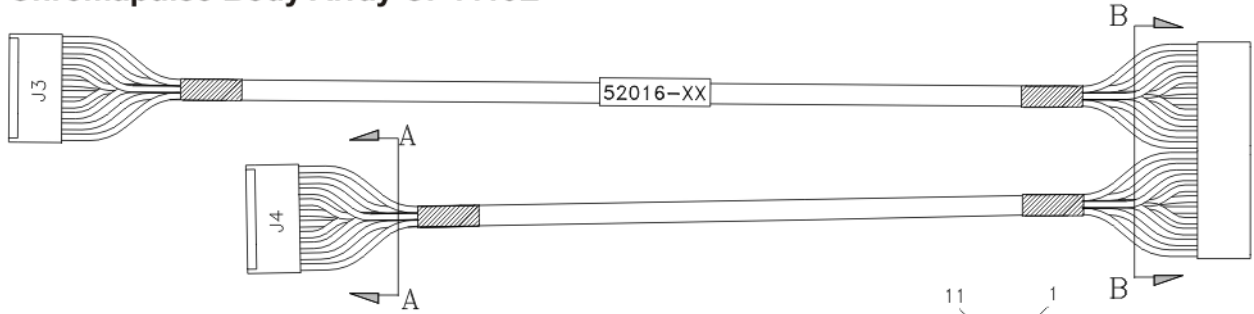

WIRING CHART			
PIN NUMBER J3 CONNECTOR	WIRE COLOR	PIN NUMBER 32-PIN CONNECTOR	DESCRIPTION
2	RED	32	ZONE_1
3	WHT	31	ZONE_2
4	GRN	30	ZONE_3
5	BLU	29	ZONE_4
6	YEL	28	ZONE_5
7	BRN	27	ZONE_6
8	ORG	26	ZONE_7
9	WHT	25	ZONE_8
11	BLACK	-	SHIELD

WIRING CHART				
PIN NUMBER J3 CONNECTOR	WIRE COLOR	PIN NUMBER 32-PIN CONNECTOR	DESCRIPTION	
PAIR 1	12	BLK	16	POWER
PAIR 2	13	BLK	15	POWER
PAIR 3	14	BLK	14	POWER
PAIR 4	15	BLK	13	POWER
PAIR 5	16	BLK	12	POWER
PAIR 6	17	BLK	11	POWER
PAIR 7	18	BLK	10	POWER
PAIR 8	19	RED	9	POWER

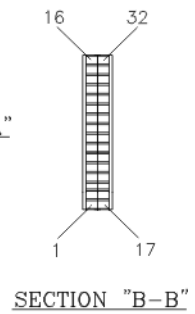
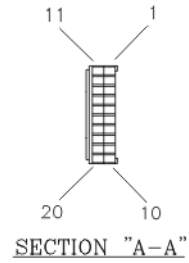

WIRING CHART			
PIN NUMBER J4 CONNECTOR	WIRE COLOR	PIN NUMBER 32-PIN CONNECTOR	DESCRIPTION
2	RED	24	ZONE_9
3	WHT	23	ZONE_10
4	GRN	22	ZONE_11
5	BLU	21	ZONE_12
6	YEL	20	ZONE_13
7	BRN	19	ZONE_14
8	ORG	18	ZONE_15
9	WHT	17	ZONE_16
11	BLACK	-	SHIELD

WIRING CHART				
PIN NUMBER J4 CONNECTOR	WIRE COLOR	PIN NUMBER 32-PIN CONNECTOR	DESCRIPTION	
PAIR 1	12	BLK	8	POWER
PAIR 2	13	BLK	7	POWER
PAIR 3	14	BLK	6	POWER
PAIR 4	15	BLK	5	POWER
PAIR 5	16	BLK	4	POWER
PAIR 6	17	BLK	3	POWER
PAIR 7	18	BLK	2	POWER
PAIR 8	19	RED	1	POWER

CP4402E inspection module

48880, 50423 Chromapulse RS485 comm. video mux.

Chromapulse RS485 Comm. Video Mux

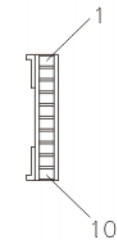
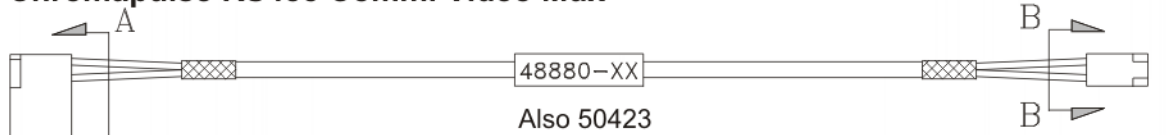

WIRING CHART			
PIN NUMBER 10-PIN CONNECTOR	WIRE COLOR	PIN NUMBER 2-PIN CONNECTOR	DESCRIPTION
1	RED	1	+485
2	BLK	2	-485
3-10	-	-	N/C

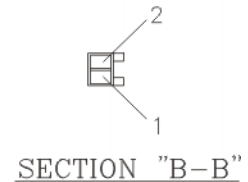

48878 Chromapulse power video mux

Chromapulse Power Video Mux

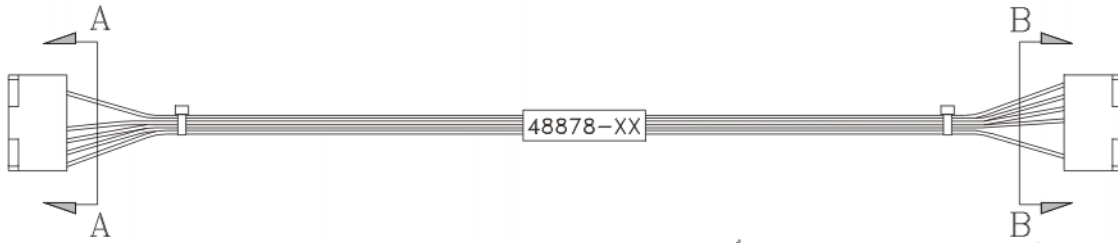

WIRING CHART			
PIN NUMBER 8-PIN CONNECTOR	WIRE COLOR	PIN NUMBER 8-PIN CONNECTOR	DESCRIPTION
1	-	-	-
2	RED	2	+5V
3	-	-	-
4	-	-	-
5	BLK	5	GND
6	BLK	6	GND
7	BLK	7	GND
8	BLK	8	GND

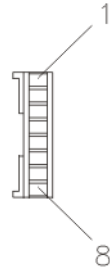

SECTION "A-A"



SECTION "B-B"

51254 Chromapulse power video mux

Chromapulse Power Video Mux

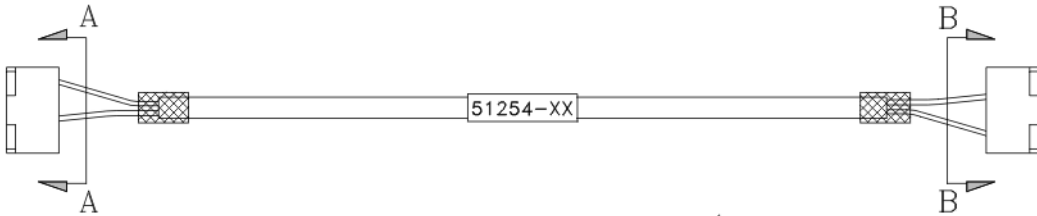

WIRING CHART			
PIN NUMBER 8-PIN CONNECTOR	WIRE COLOR	PIN NUMBER 8-PIN CONNECTOR	DESCRIPTION
1	-	-	-
2	RED	2	+5V
3	-	-	-
4	-	-	-
5	BLK	5	GND
6	-	-	-
7	-	-	-
8	-	-	-

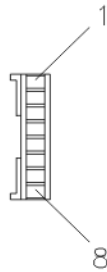

SECTION "A-A"

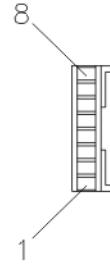

SECTION "B-B"

51255 Chromapulse camera control video mux

Chromapulse Camera Control Video Mux

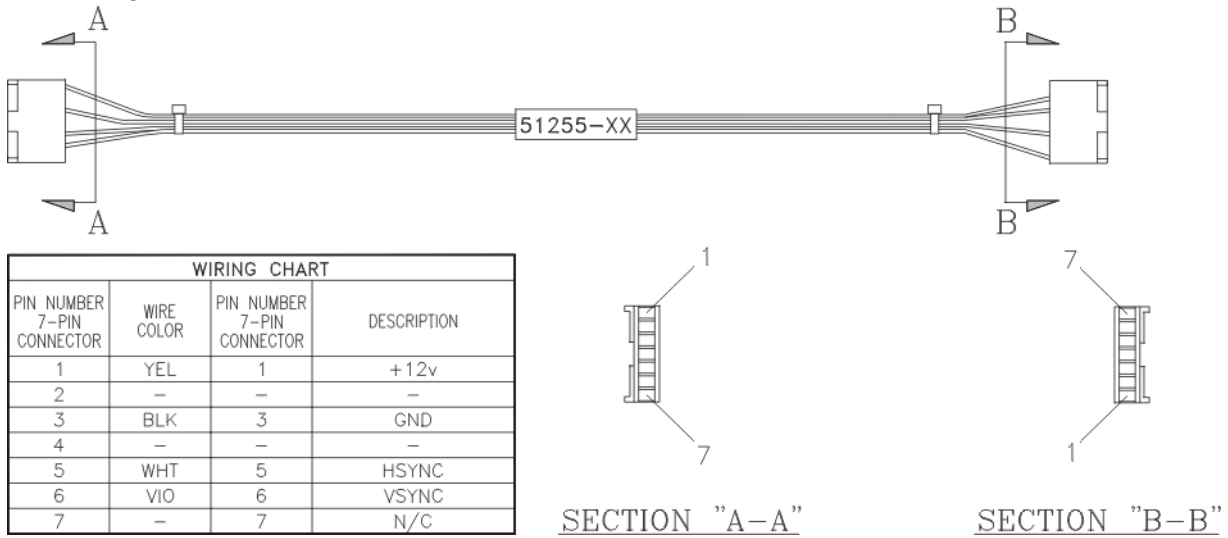

52019, 52017, 51645, 52024 Chromapulse camera control 90 degrees

Chromapulse Camera Control 90 degrees

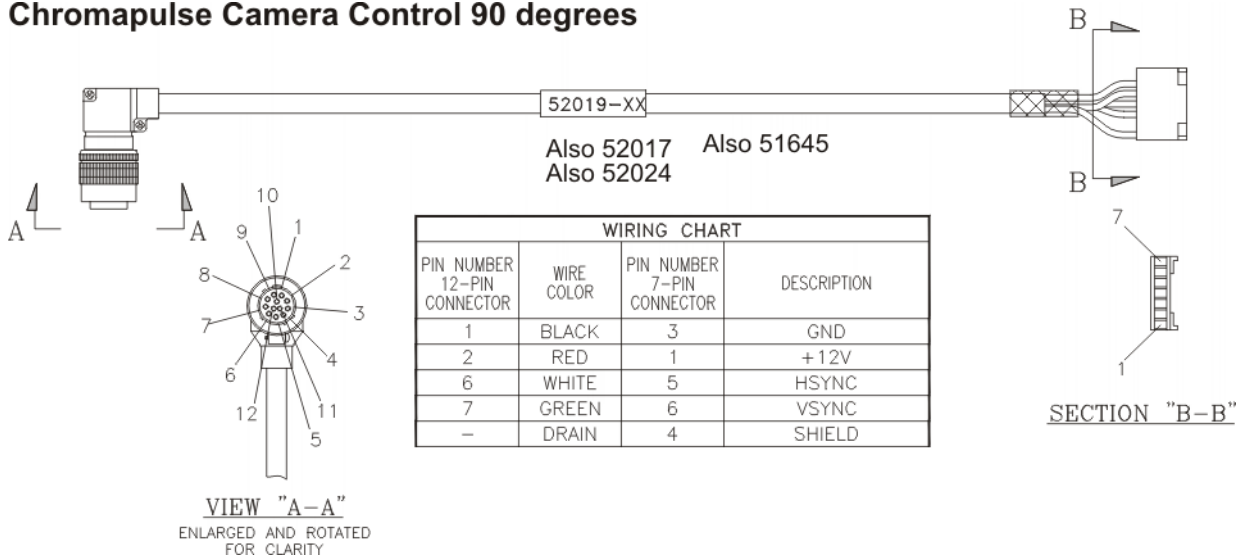

52883 Chromapulse dome/ flange array

Chromapulse Dome/Flange Array CP4402E

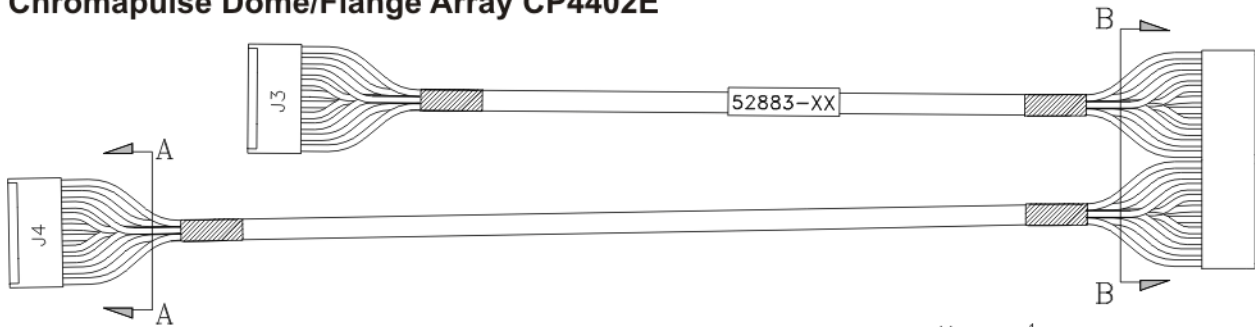

WIRING CHART			
PIN NUMBER J3 CONNECTOR	WIRE COLOR	PIN NUMBER 32-PIN CONNECTOR	DESCRIPTION
2	RED	32	ZONE_1
3	WHT	31	ZONE_2
4	GRN	30	ZONE_3
5	BLU	29	ZONE_4
6	YEL	28	ZONE_5
7	BRN	27	ZONE_6
8	ORG	26	ZONE_7
9	WHT	25	ZONE_8
11	BLACK	-	SHIELD

PAIR 1
PAIR 2
PAIR 3
PAIR 4
PAIR 5
PAIR 6
PAIR 7
PAIR 8

WIRING CHART			
PIN NUMBER J3 CONNECTOR	WIRE COLOR	PIN NUMBER 32-PIN CONNECTOR	DESCRIPTION
12	BLK	16	POWER
13	BLK	15	POWER
14	BLK	14	POWER
15	BLK	13	POWER
16	BLK	12	POWER
17	BLK	11	POWER
18	BLK	10	POWER
19	RED	9	POWER

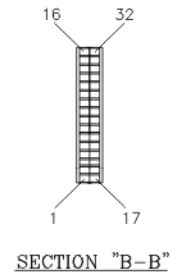
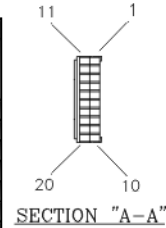

WIRING CHART			
PIN NUMBER J4 CONNECTOR	WIRE COLOR	PIN NUMBER 32-PIN CONNECTOR	DESCRIPTION
2	RED	24	ZONE_9
3	WHT	23	ZONE_10
4	GRN	22	ZONE_11
5	BLU	21	ZONE_12
6	YEL	20	ZONE_13
7	BRN	19	ZONE_14
8	ORG	18	ZONE_15
9	WHT	17	ZONE_16
11	BLACK	-	SHIELD

PAIR 1
PAIR 2
PAIR 3
PAIR 4
PAIR 5
PAIR 6
PAIR 7
PAIR 8

WIRING CHART			
PIN NUMBER J4 CONNECTOR	WIRE COLOR	PIN NUMBER 32-PIN CONNECTOR	DESCRIPTION
12	BLK	8	POWER
13	BLK	7	POWER
14	BLK	6	POWER
15	BLK	5	POWER
16	BLK	4	POWER
17	BLK	3	POWER
18	BLK	2	POWER
19	RED	1	POWER

52020, 52878 Chromapulse neck/ flange array

Chromapulse Neck/ Flange Array

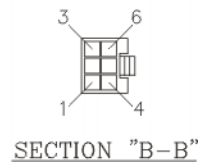
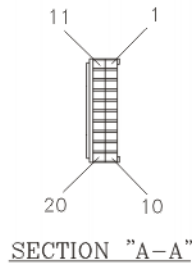
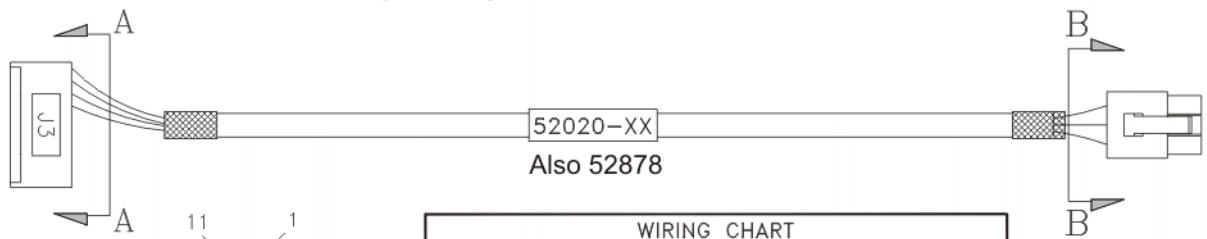

WIRING CHART			
PIN NUMBER 20-PIN CONNECTOR	WIRE COLOR	PIN NUMBER 6-PIN CONNECTOR	DESCRIPTION
2	BLK	1	ZONE1
3	GRN	2	ZONE2
4	BRN	3	ZONE3
12	WHT	4	+48V
13	RED	5	+48V
11	DRAIN	-	SHIELD

CP4411E, CP4412E inspection modules

56842 four camera umbilical inside cabinet

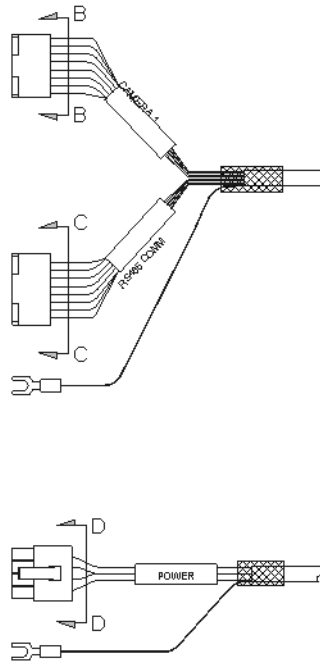
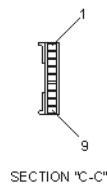
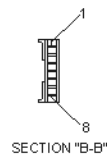
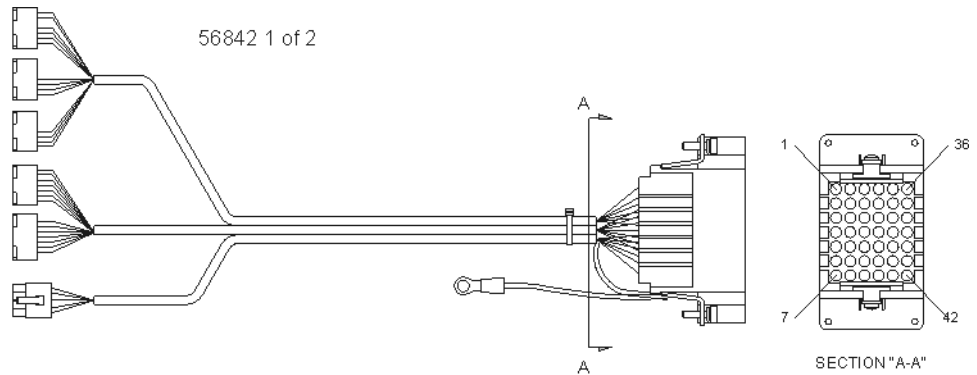

WIRING CHART				CAMERA 1
PIN NUMBER CAMERA 1 CONNECTOR	WIRE COLOR	PIN NUMBER 42-PIN CONNECTOR	DESCRIPTION	
1	BLK	41	-STROBE_TRIG_1	
2	BLU	34	+STROBE_TRIG_1	
3	BLK	40	-STROBE_RESET	
4	GRN	33	+STROBE_RESET	
5	BLK	37	-HSYNC_1	
6	WHT	30	+HSYNC_1	
7	BLK	39	-ASYNC_RESET_1	
8	RED	32	+ASYNC_RESET_1	

WIRING CHART				RS485 COMM
PIN NUMBER 9-PIN CONNECTOR	WIRE COLOR	PIN NUMBER 42-PIN CONNECTOR	DESCRIPTION	
1	-	-	N/C	
2	WHT	28	LCTXD -IN	
3	RED	27	LCTXD +IN	
4	BLK	42	LCTXD -OUT	
5	ORG	35	LCTXD +OUT	
6	BLK	21	FCTXD -IN	
7	BRN	20	FCTXD +IN	
8	BLK	14	FCTXD -OUT	
9	YEL	7	FCTXD +OUT	

WIRING CHART				CAMERA/ROLLER/POWER
PIN NUMBER 8-PIN CONNECTOR	WIRE COLOR	PIN NUMBER 42-PIN CONNECTOR	DESCRIPTION	
1	WHT	1	+12V	
2	RED	5	+6V	
3	ORG	4	+12V	
4	YEL	3	+48V	
5	BLK	8	12V _A RET	
6	GRN	9	GND	
7	BLU	11	GND	
8	BRN	10	+48V RET	

WIRING CHART			
PIN NUMBER CAMERA 2 CONNECTOR	WIRE COLOR	PIN NUMBER 42-PIN CONNECTOR	DESCRIPTION
1	-	-	-
2	-	-	-
3	-	-	-
4	-	-	-
5	BLK	22	-HSYNC_2
6	WHT	15	+HSYNC_2
7	BLK	23	-ASYNC_RESET_2
8	RED	16	+ASYNC_RESET_2

WIRING CHART			
PIN NUMBER CAMERA 3 CONNECTOR	WIRE COLOR	PIN NUMBER 42-PIN CONNECTOR	DESCRIPTION
1	-	-	-
2	-	-	-
3	-	-	-
4	-	-	-
5	BLK	38	-HSYNC_3
6	BLU	31	+HSYNC_3
7	BLK	36	-ASYNC_RESET_3
8	YEL	29	+ASYNC_RESET_3

WIRING CHART			
PIN NUMBER CAMERA 4 CONNECTOR	WIRE COLOR	PIN NUMBER 42-PIN CONNECTOR	DESCRIPTION
1	BLK	24	-STROBE_TRIG_2
2	GRN	17	+STROBE_TRIG_2
3	-	-	-
4	-	-	-
5	BLK	26	-HSYNC_4
6	BRN	19	+HSYNC_4
7	BLK	25	-ASYNC_RESET_4
8	ORG	18	+ASYNC_RESET_4

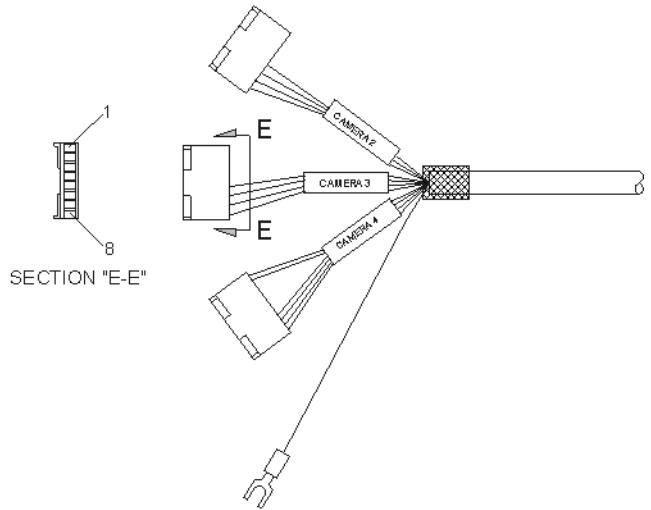

Umbilical camera CP4411E

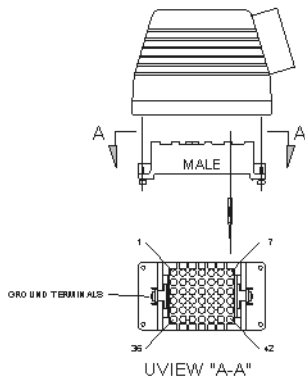
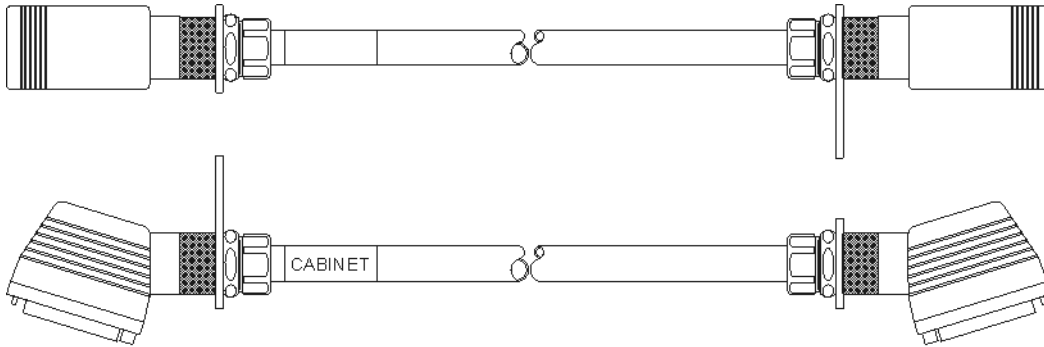

WIRING CHART	
PIN NO.	DESCRIPTION
1	+12L
2	N/C
3	+48V
4	+12V
5	+5V
6	N/C
7	FC_485+
8	+12LRET
9	GND
10	GND
11	GND
12	N/C
13	N/C
14	FC_485-
15	+Hsync_2
16	+Async_Reset_2
17	+Strobe_Trigger_2
18	N/C
19	N/C
20	FC_485+ RET
21	FC_485- RET

WIRING CHART	
PIN NO.	DESCRIPTION
22	-Hsync_2
23	-Async_Reset_2
24	-Strobe_Trigger_2
25	N/C
26	N/C
27	LC_485+ RET
28	LC_485- RET
29	N/C
30	+Hsync_1
31	N/C
32	+Async_Reset_1
33	+Strobe_Reset_1
34	+Strobe_Trigger_1
35	LC_485+
36	N/C
37	-Hsync_1
38	N/C
39	-Async_Reset_1
40	-Strobe_Reset_1
41	-Strobe_Trigger_1
42	LC_485-

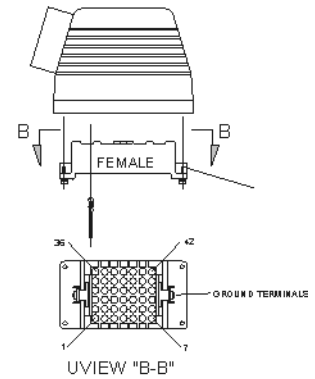

Umbilical camera CP4412E braided

58634

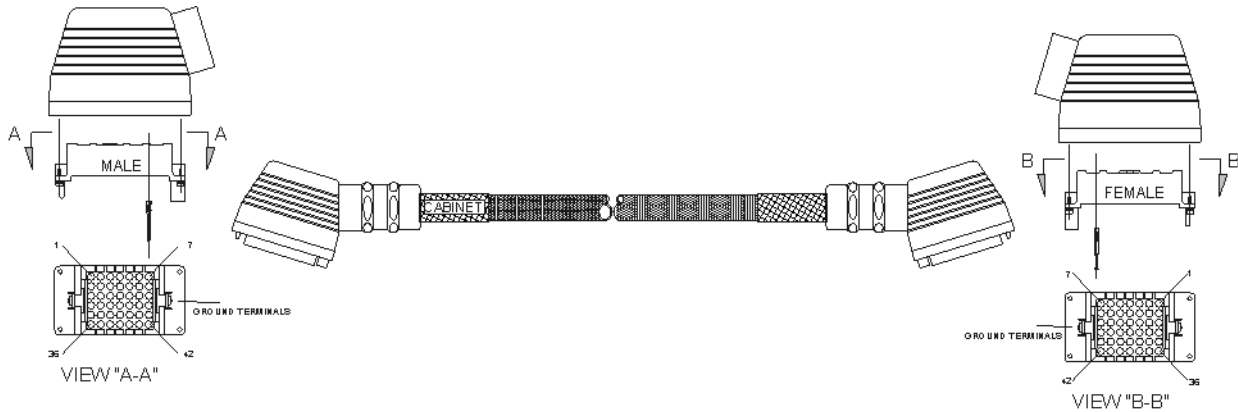

WIRING CHART 'CAM1/COMM' CABLE

WIRING CHART			
PIN NUMBER 42P MALE CONNECTOR	WIRE COLOR	PIN NUMBER 42P FEMALE CONNECTOR	DESCRIPTION
7	RED	7	+FC_485_OUT
20	WHT	20	+FC_485_IN
27	GRN	27	+LC_485_IN
30	BLU	30	+Hsync_1
32	YEL	32	+Async_Reset_1
33	BRN	33	+Strobe_Reset_1
34	ORG	34	+Strobe_Trig_1
35	WHT	35	+LC_485_OUT

WIRING CHART 'CAM1/COMM' CABLE

WIRING CHART			
PIN NUMBER 42P MALE CONNECTOR	WIRE COLOR	PIN NUMBER 42P FEMALE CONNECTOR	DESCRIPTION
14	BLK	14	-FC_485_OUT
21	BLK	21	-FC_485_IN
28	BLK	28	-LC_485_IN
37	BLK	37	-Hsync_1
39	BLK	39	-Async_Reset_1
40	BLK	40	-Strobe_Reset_1
41	BLK	41	-Strobe_Trig_1
42	RED	42	-LC_485_OUT

WIRING CHART 'CAM2,3,4' CABLE

WIRING CHART			
PIN NUMBER 42P MALE CONNECTOR	WIRE COLOR	PIN NUMBER 42P FEMALE CONNECTOR	DESCRIPTION
15	WHT	15	+Hsync_2
16	RED	16	+Async_Reset_2
17	GRN	17	+Strobe_Trig_2
18	ORG	18	+Async_Reset_4
19	BRN	19	+Hsync_4
29	YEL	29	+Async_Reset_3
31	BLU	31	+Hsync_3

WIRING CHART 'CAM2,3,4' CABLE

WIRING CHART			
PIN NUMBER 42P MALE CONNECTOR	WIRE COLOR	PIN NUMBER 42P FEMALE CONNECTOR	DESCRIPTION
22	BLK	22	-Hsync_2
23	BLK	23	-Async_Reset_2
24	BLK	24	-Strobe_Trig_2
25	BLK	25	-Async_Reset_4
26	BLK	26	-Hsync_4
36	BLK	36	-Async_Reset_3
38	BLK	38	-Hsync_3

CABLE CAMERA MODULE POWER

WIRING CHART			
PIN NUMBER 42P MALE CONNECTOR	WIRE COLOR	PIN NUMBER 42P FEMALE CONNECTOR	DESCRIPTION
1	BLK	1	+12VL
3	RED	3	+48V
4	WHT	4	+12V
5	GRN	5	+5V
8	ORG	8	GND
9	BLU	9	GND
10	BRN	10	GND
11	YEL	11	GND

Umbilical camera/ video CP4412E S IV-D

58652, 57291, 57597, 58033, 58227, 59243, 59463, 59510

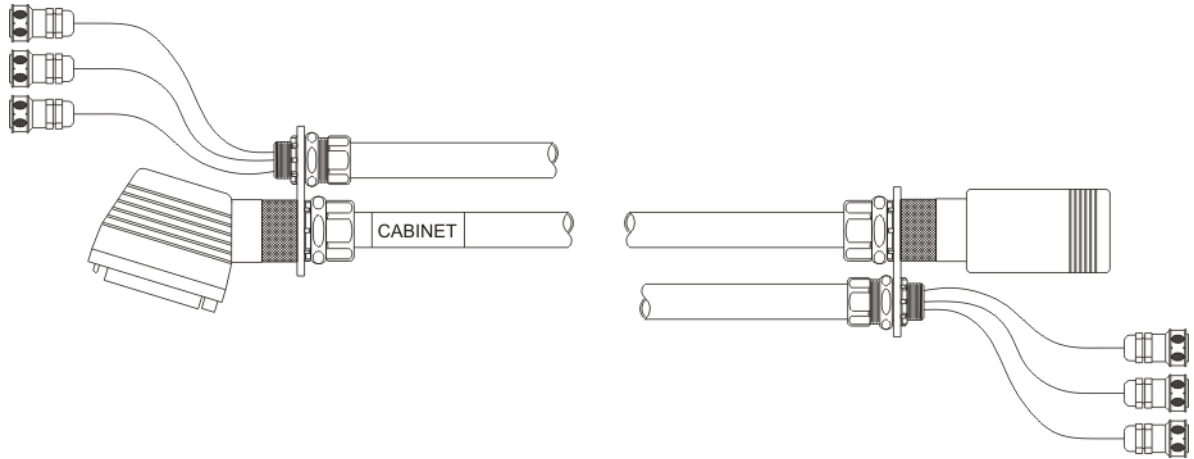

Umbilical camera CP4412E S IV-D

58645, 57289, 57596, 58032, 58226, 58498, 58501, 59242, 59462, 59509

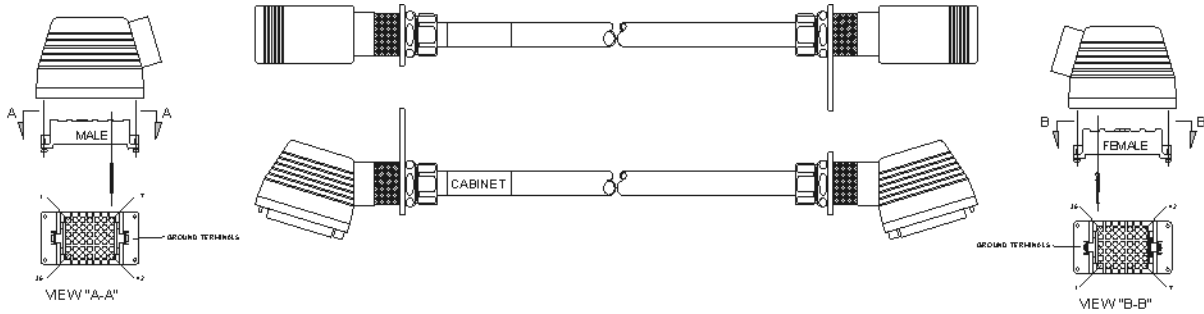

WIRING CHART 'CAM1/COMM' CABLE

WIRING CHART			
PIN NUMBER 42P MALE CONNECTOR	WIRE COLOR	PIN NUMBER 42P FEMALE CONNECTOR	DESCRIPTION
7	RED	7	+FC_485_OUT
20	WHT	20	+FC_485_IN
27	GRN	27	+LC_485_IN
30	BLU	30	+Hsync_1
32	YEL	32	+Async_Reset_1
33	BRN	33	+Strobe_Reset_1
34	ORG	34	+Strobe_Trig_1
35	WHT	35	+LC_485_OUT

— PAIR —
— PAIR —
— PAIR —
— PAIR —
— PAIR —
— PAIR —
— PAIR —
— PAIR —

WIRING CHART 'CAM1/COMM' CABLE

WIRING CHART			
PIN NUMBER 42P MALE CONNECTOR	WIRE COLOR	PIN NUMBER 42P FEMALE CONNECTOR	DESCRIPTION
14	BLK	14	-FC_485_OUT
21	BLK	21	-FC_485_IN
28	BLK	28	-LC_485_IN
37	BLK	37	-Hsync_1
39	BLK	39	-Async_Reset_1
40	BLK	40	-Strobe_Reset_1
41	BLK	41	-Strobe_Trig_1
42	RED	42	-LC_485_OUT

WIRING CHART 'CAM2,3,4' CABLE

WIRING CHART			
PIN NUMBER 42P MALE CONNECTOR	WIRE COLOR	PIN NUMBER 42P FEMALE CONNECTOR	DESCRIPTION
15	WHT	15	+Hsync_2
16	RED	16	+Async_Reset_2
17	GRN	17	+Strobe_Trig_2
18	ORG	18	+Async_Reset_4
19	BRN	19	+Hsync_4
29	YEL	29	+Async_Reset_3
31	BLU	31	+Hsync_3

— PAIR —
— PAIR —
— PAIR —
— PAIR —
— PAIR —
— PAIR —
— PAIR —

WIRING CHART 'CAM2,3,4' CABLE

WIRING CHART			
PIN NUMBER 42P MALE CONNECTOR	WIRE COLOR	PIN NUMBER 42P FEMALE CONNECTOR	DESCRIPTION
22	BLK	22	-Hsync_2
23	BLK	23	-Async_Reset_2
24	BLK	24	-Strobe_Trig_2
25	BLK	25	-Async_Reset_4
26	BLK	26	-Hsync_4
36	BLK	36	-Async_Reset_3
38	BLK	38	-Hsync_3

WIRING CHART CAMERA MODULE POWER

WIRING CHART			
PIN NUMBER 42P MALE CONNECTOR	WIRE COLOR	PIN NUMBER 42P FEMALE CONNECTOR	DESCRIPTION
1	BLK	1	+12V
3	RED	3	+48V
4	WHT	4	+1.2V
5	GRN	5	+5V
8	ORG	8	GND
9	BLU	9	GND
10	BRN	10	GND
11	YEL	11	GND

Umbilical video Series IV-D CP4412E

56844, 57288, 57595, 58031, 58225, 58495, 58500, 59241, 59461, 59508

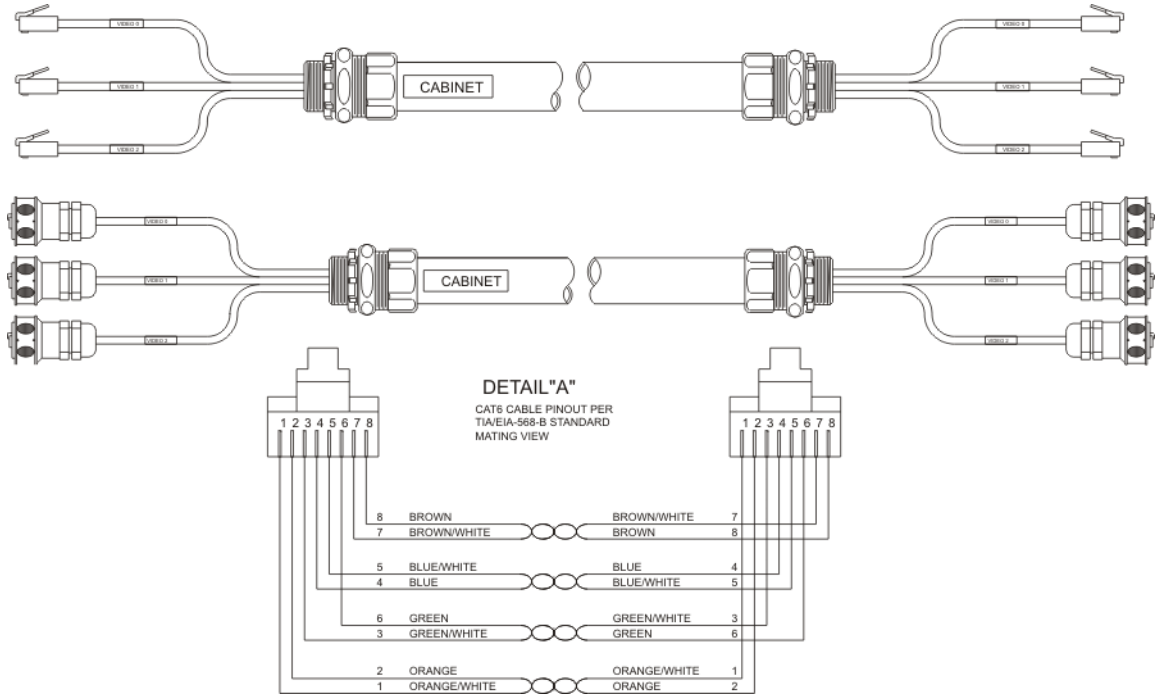

Umbilical camera/ video CP4411E S IV-D

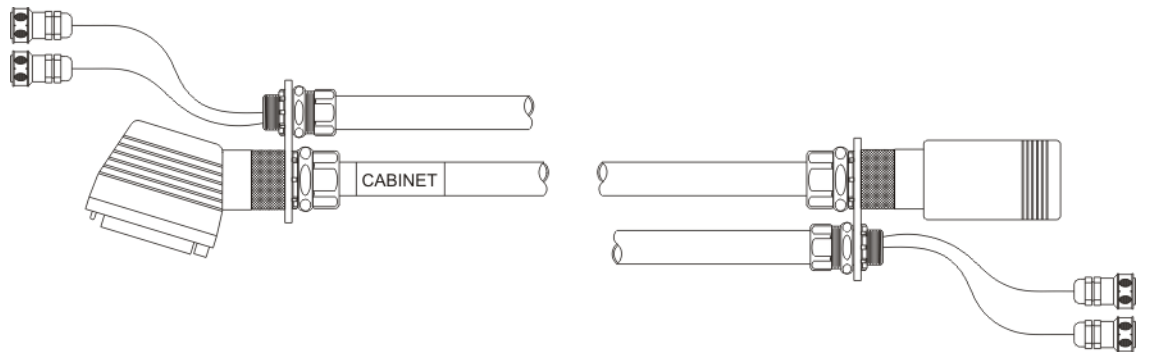

Umbilical camera/ video CP4412E S IV

56851, 57290

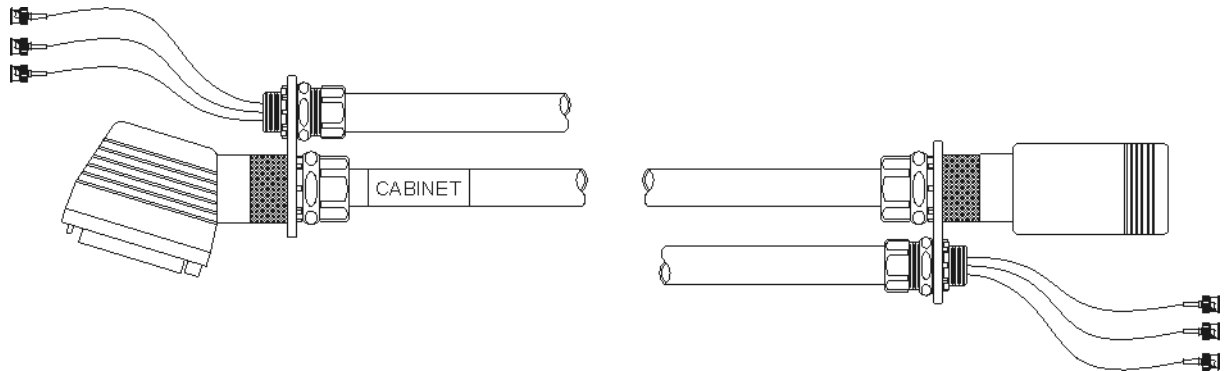

Umbilical camera/ video CP4411E

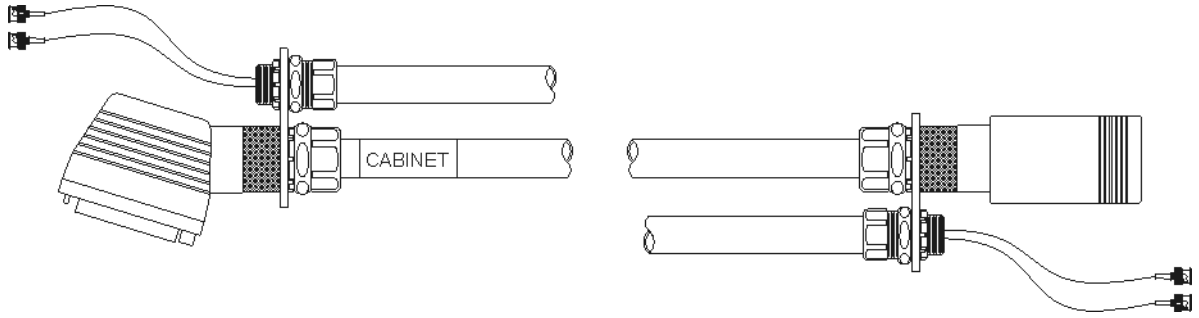

Umbilical 2 camera dual tap 16 zone CP4411

50131

50131 page 1 of 2

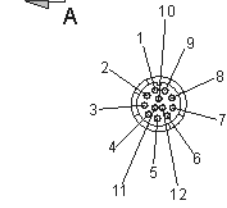
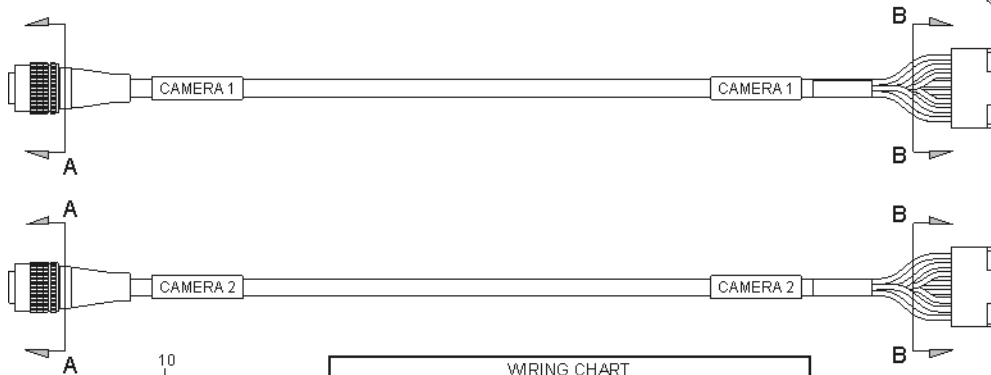
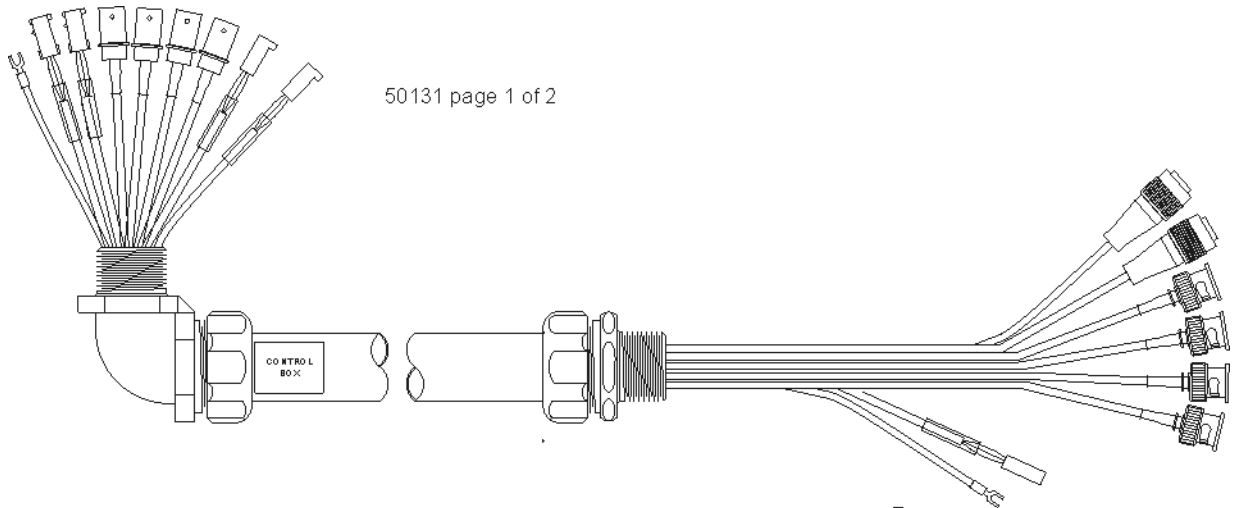

SECTION "A-A"

WIRING CHART			
PIN NUMBER 7-PIN CONNECTOR	WIRE COLOR	PIN NUMBER 12-PIN CONNECTOR	DESCRIPTION
1	RED	2	+12V IN
3	BLACK	1	GND
5	WHITE	6	HSync
6	GREEN	7	VSync
4	BLACK	-	SHIELD*

*SOLDER ITEM 2 TO BRAID FOR SHIELD TERMINATION.

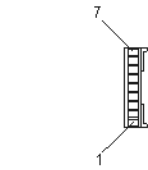

SECTION "B-B"

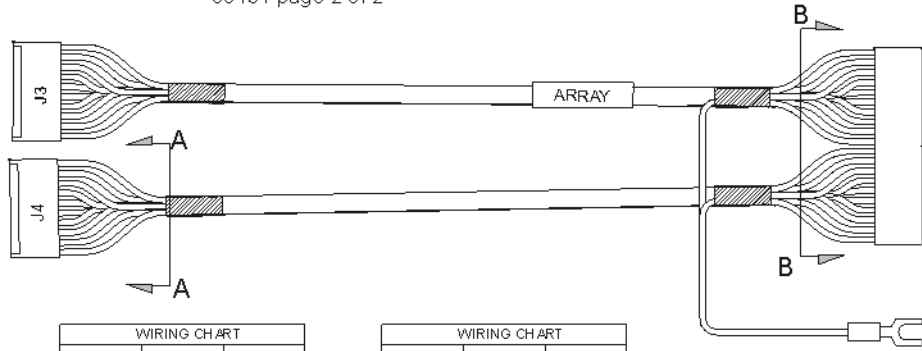
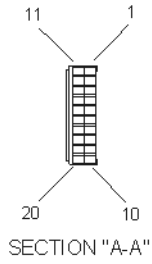

WIRING CHART		
PIN NUMBER J3 CONNECTOR	WIRE COLOR	PIN LETTER POWER CONNECTOR
2	WHITE	32
3	GREEN	31
4	BLUE	30
5	YELLOW	29
6	RED(BLK)	28
7	BROWN	27
8	ORANGE	26
9	RED(WHT)	25
12	BLK(WHT)	16
13	BLK(GRN)	15
14	BLK(BLUE)	14
15	BLK(YEL)	13
16	BLK(RED)	12
17	BLK(BRWN)	11
18	BLK(ORNG)	10
19	WHT(RED)	9
11	SHIELD	NC

WIRING CHART		
PIN NUMBER J4 CONNECTOR	WIRE COLOR	PIN LETTER POWER CONNECTOR
2	WHITE	24
3	GREEN	23
4	BLUE	22
5	YELLOW	21
6	RED(BLK)	20
7	BROWN	19
8	ORANGE	18
9	RED(WHT)	17
12	BLK(WHT)	8
13	BLK(GRN)	7
14	BLK(BLUE)	6
15	BLK(YEL)	5
16	BLK(RED)	4
17	BLK(BRWN)	3
18	BLK(ORNG)	2
19	WHT(RED)	1
20	SHIELD	NC

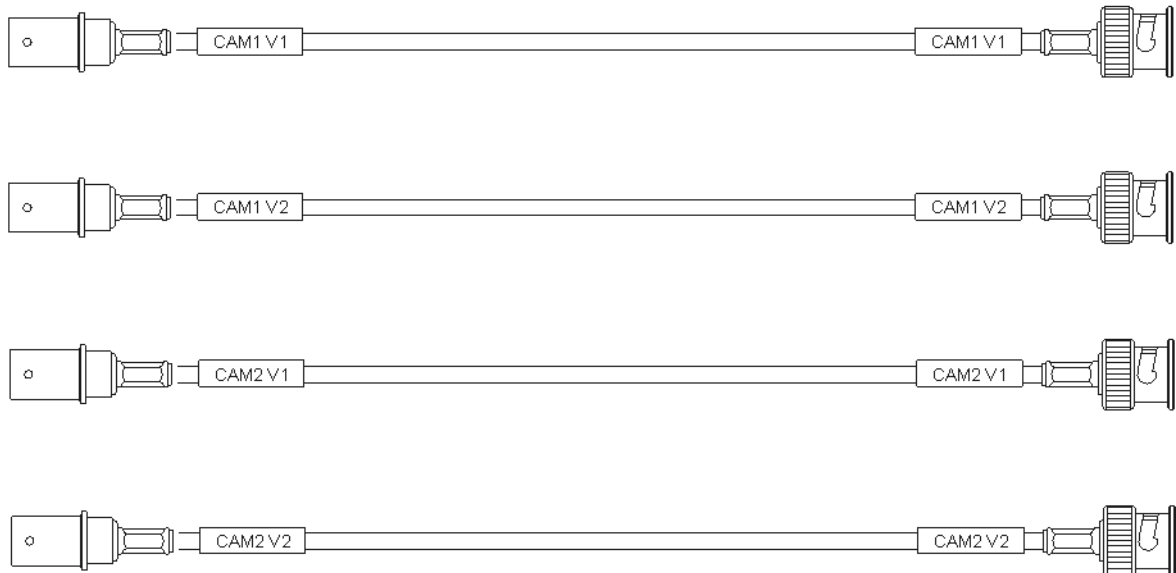
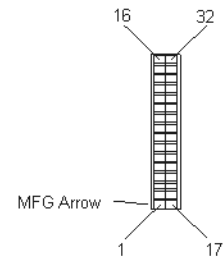

Umbilical video 3 CAT6 S IV-D CP4412E

58635

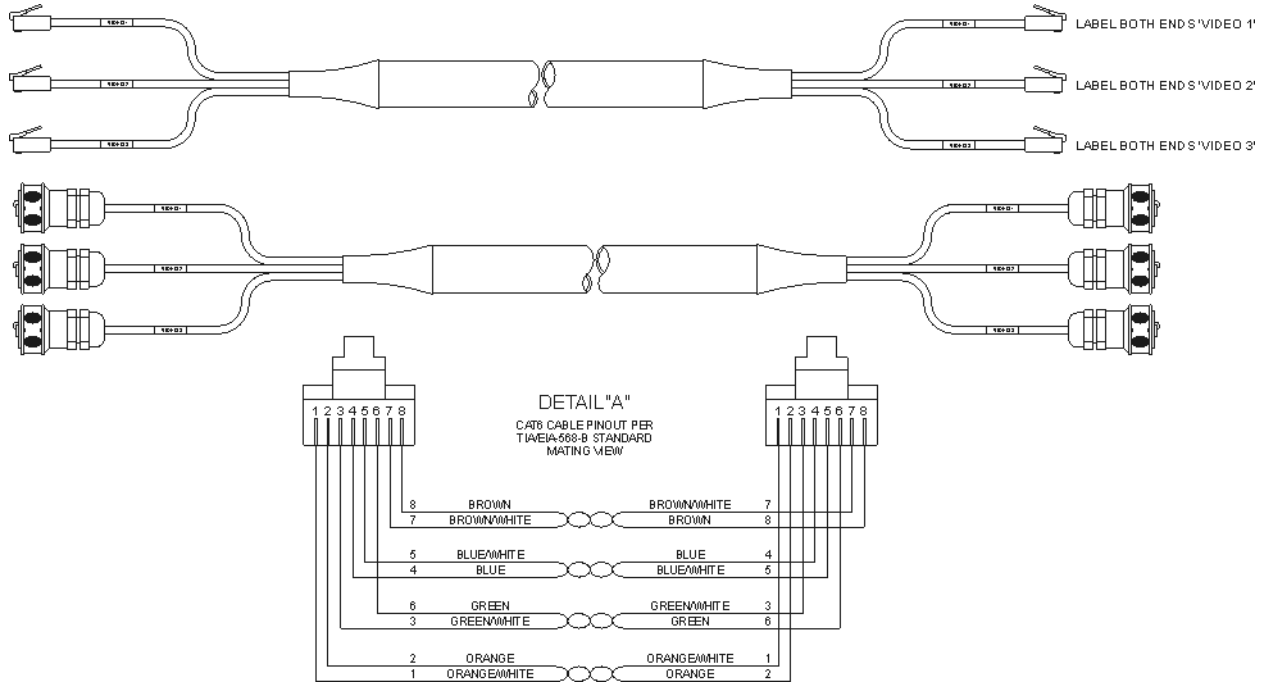

Umbilical video Series IV

CP4412E 58643, 57287

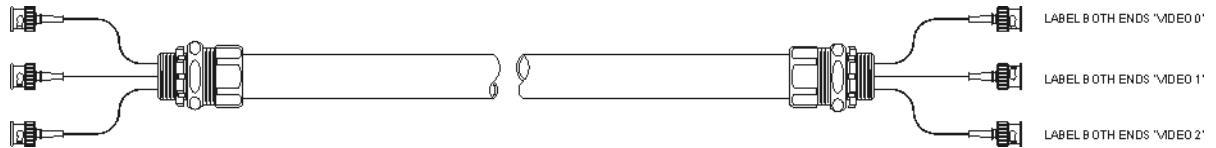

Umbilical control box CP4412

56472

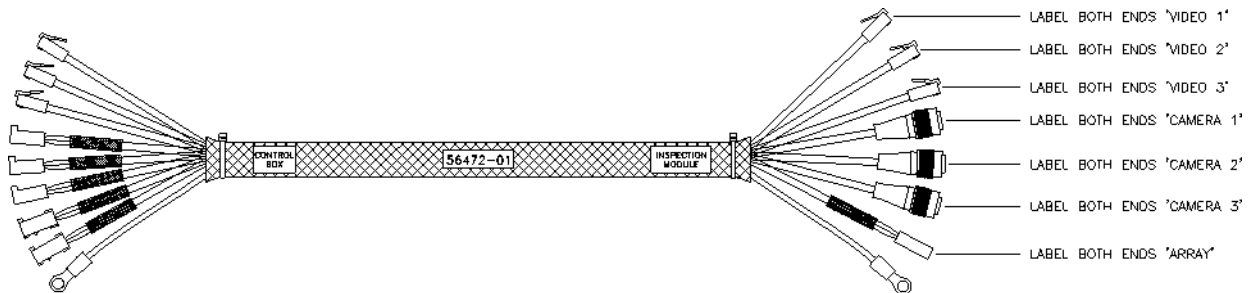

52019, 52017, 51645, 52024 Chromapulse camera control 90 degrees

Chromapulse Camera Control 90 degrees

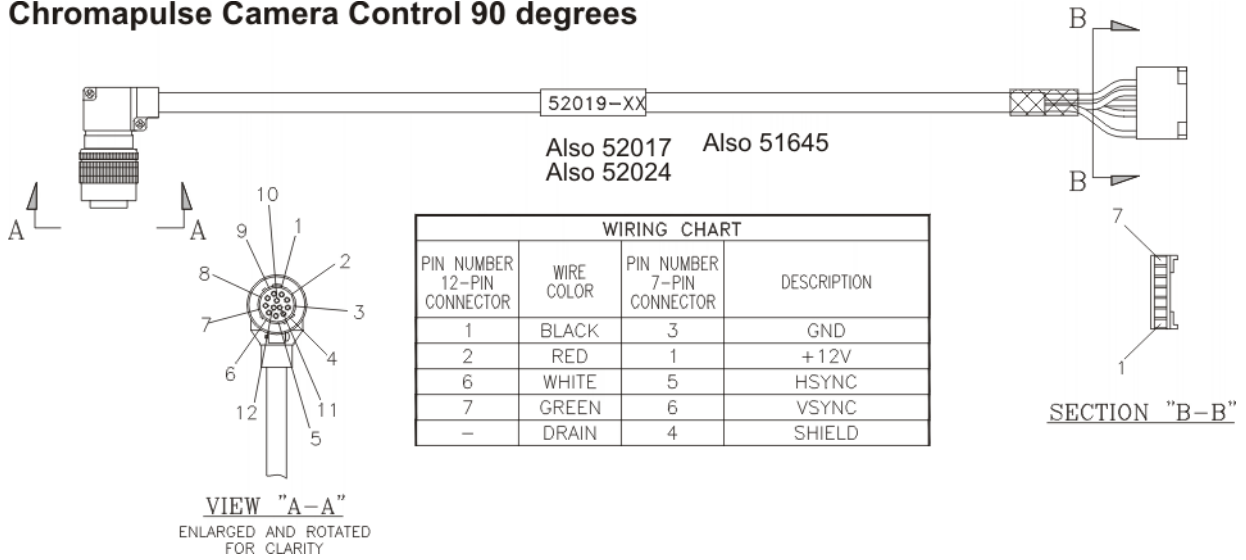

GIG-E camera control CP

55961, 56014, 58013

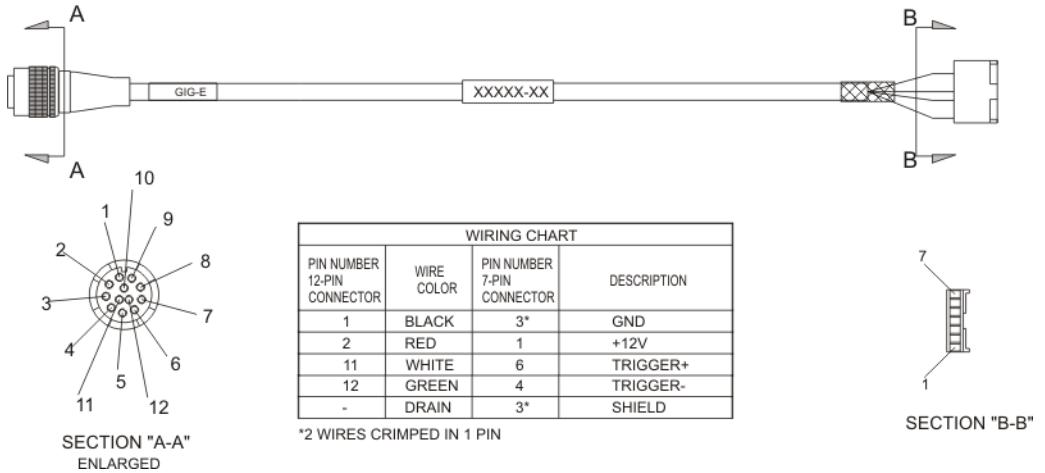

51218, 51048 Chromapulse array

Also 56841 CP4412E

Chromapulse Array CP4410E, CP4411, CP4412

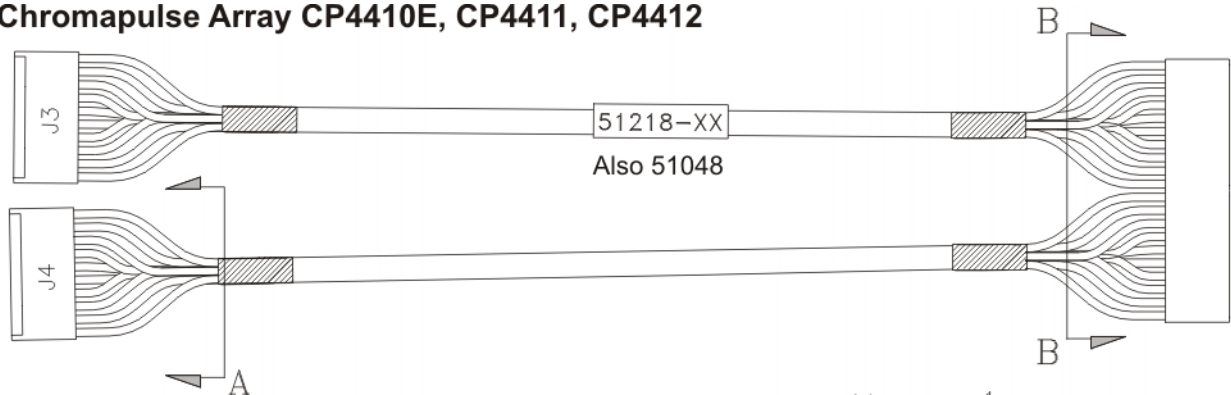

WIRING CHART			
PIN NUMBER J3 CONNECTOR	WIRE COLOR	PIN NUMBER 32-PIN CONNECTOR	DESCRIPTION
2	RED	32	ZONE_1
3	WHT	31	ZONE_2
4	GRN	30	ZONE_3
5	BLU	29	ZONE_4
6	YEL	28	ZONE_5
7	BRN	27	ZONE_6
8	ORG	26	ZONE_7
9	WHT	25	ZONE_8
11	BLACK	-	SHIELD

WIRING CHART			
PIN NUMBER J3 CONNECTOR	WIRE COLOR	PIN NUMBER 32-PIN CONNECTOR	DESCRIPTION
12	BLK	16	POWER
13	BLK	15	POWER
14	BLK	14	POWER
15	BLK	13	POWER
16	BLK	12	POWER
17	BLK	11	POWER
18	BLK	10	POWER
19	RED	9	POWER

WIRING CHART			
PIN NUMBER J4 CONNECTOR	WIRE COLOR	PIN NUMBER 32-PIN CONNECTOR	DESCRIPTION
2	RED	24	ZONE_9
3	WHT	23	ZONE_10
4	GRN	22	ZONE_11
5	BLU	21	ZONE_12
6	YEL	20	ZONE_13
7	BRN	19	ZONE_14
8	ORG	18	ZONE_15
9	WHT	17	ZONE_16
11	BLACK	-	SHIELD

WIRING CHART			
PIN NUMBER J4 CONNECTOR	WIRE COLOR	PIN NUMBER 32-PIN CONNECTOR	DESCRIPTION
12	BLK	8	POWER
13	BLK	7	POWER
14	BLK	6	POWER
15	BLK	5	POWER
16	BLK	4	POWER
17	BLK	3	POWER
18	BLK	2	POWER
19	RED	1	POWER

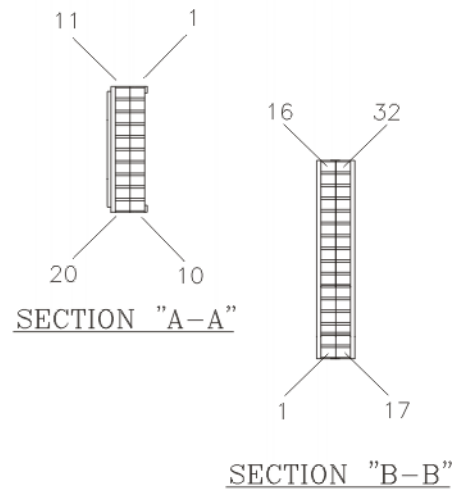

56841 array CP4412E

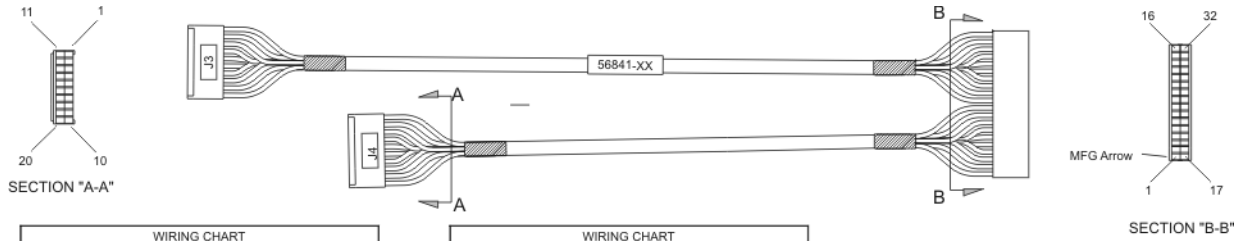

WIRING CHART			
PIN NUMBER J3 CONNECTOR	WIRE COLOR	PIN NUMBER 32-PIN CONNECTOR	DESCRIPTION
2	RED	32	ZONE_1
3	WHT	31	ZONE_2
4	GRN	30	ZONE_3
5	BLU	29	ZONE_4
6	YEL	28	ZONE_5
7	BRN	27	ZONE_6
8	ORG	26	ZONE_7
9	WHT	25	ZONE_8
11	BLACK	-	SHIELD

WIRING CHART					
PIN NUMBER J3 CONNECTOR	WIRE COLOR	PIN NUMBER 32-PIN CONNECTOR	DESCRIPTION		
PAIR 1		12	BLK	16	POWER
PAIR 2		13	BLK	15	POWER
PAIR 3		14	BLK	14	POWER
PAIR 4		15	BLK	13	POWER
PAIR 5		16	BLK	12	POWER
PAIR 6		17	BLK	11	POWER
PAIR 7		18	BLK	10	POWER
PAIR 8		19	RED	9	POWER

WIRING CHART			
PIN NUMBER J4 CONNECTOR	WIRE COLOR	PIN NUMBER 32-PIN CONNECTOR	DESCRIPTION
2	RED	24	ZONE_9
3	WHT	23	ZONE_10
4	GRN	22	ZONE_11
5	BLU	21	ZONE_12
6	YEL	20	ZONE_13
7	BRN	19	ZONE_14
8	ORG	18	ZONE_15
9	WHT	17	ZONE_16
11	BLACK	-	SHIELD

WIRING CHART					
PIN NUMBER J4 CONNECTOR	WIRE COLOR	PIN NUMBER 32-PIN CONNECTOR	DESCRIPTION		
PAIR 1		12	BLK	8	POWER
PAIR 2		13	BLK	7	POWER
PAIR 3		14	BLK	6	POWER
PAIR 4		15	BLK	5	POWER
PAIR 5		16	BLK	4	POWER
PAIR 6		17	BLK	3	POWER
PAIR 7		18	BLK	2	POWER
PAIR 8		19	RED	1	POWER

51049 Chromapulse camera control

Chromapulse Camera Control CP4411, CP4412

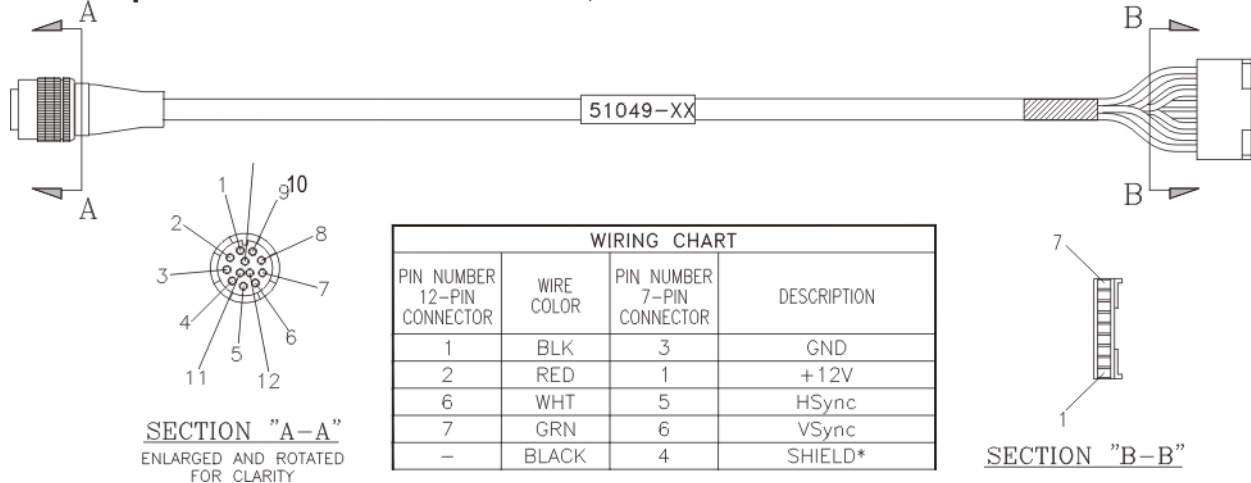

WIRING CHART			
PIN NUMBER 12-PIN CONNECTOR	WIRE COLOR	PIN NUMBER 7-PIN CONNECTOR	DESCRIPTION
1	BLK	3	GND
2	RED	1	+12V
6	WHT	5	HSync
7	GRN	6	VSynC
-	BLACK	4	SHIELD*

CP4422E inspection module

Chromapulse RS485 signal return

52015, 53662

Chromapulse RS485 Signal Return

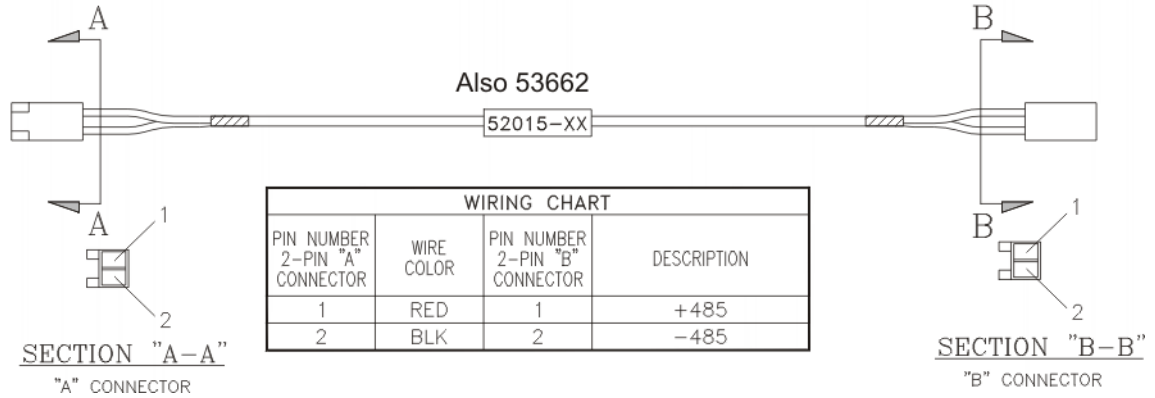

59411 array cable (short)

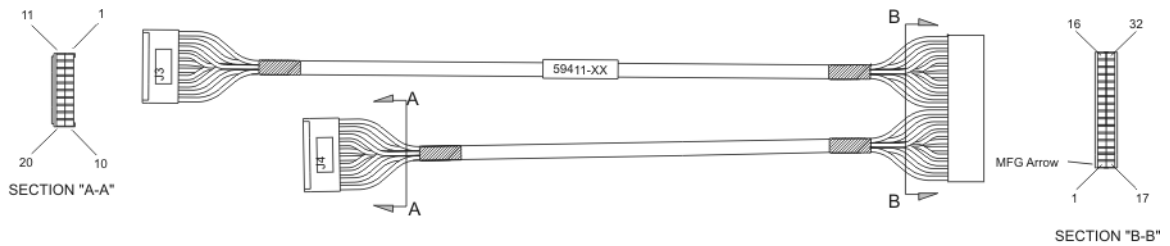

WIRING CHART			
PIN NUMBER J3 CONNECTOR	WIRE COLOR	PIN NUMBER 32-PIN CONNECTOR	DESCRIPTION
2	RED	32	ZONE_1
3	WHT	31	ZONE_2
4	GRN	30	ZONE_3
5	BLU	29	ZONE_4
6	YEL	28	ZONE_5
7	BRN	27	ZONE_6
8	ORG	26	ZONE_7
9	WHT	25	ZONE_8
11	BLACK	-	SHIELD

WIRING CHART			
PIN NUMBER J3 CONNECTOR	WIRE COLOR	PIN NUMBER 32-PIN CONNECTOR	DESCRIPTION
12	BLK	16	POWER
13	BLK	15	POWER
14	BLK	14	POWER
15	BLK	13	POWER
16	BLK	12	POWER
17	BLK	11	POWER
18	BLK	10	POWER
19	RED	9	POWER

WIRING CHART			
PIN NUMBER J4 CONNECTOR	WIRE COLOR	PIN NUMBER 32-PIN CONNECTOR	DESCRIPTION
2	RED	24	ZONE_9
3	WHT	23	ZONE_10
4	GRN	22	ZONE_11
5	BLU	21	ZONE_12
6	YEL	20	ZONE_13
7	BRN	19	ZONE_14
8	ORG	18	ZONE_15
9	WHT	17	ZONE_16
11	BLACK	-	SHIELD

WIRING CHART			
PIN NUMBER J4 CONNECTOR	WIRE COLOR	PIN NUMBER 32-PIN CONNECTOR	DESCRIPTION
12	BLK	8	POWER
13	BLK	7	POWER
14	BLK	6	POWER
15	BLK	5	POWER
16	BLK	4	POWER
17	BLK	3	POWER
18	BLK	2	POWER
19	RED	1	POWER

59412 array cable (long)

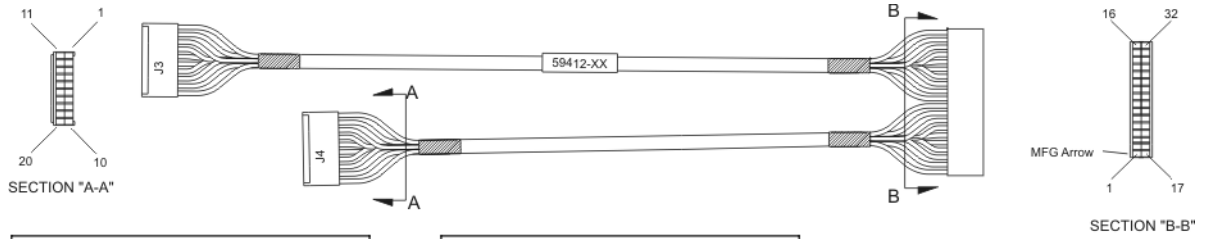

WIRING CHART			
PIN NUMBER J3 CONNECTOR	WIRE COLOR	PIN NUMBER 32-PIN CONNECTOR	DESCRIPTION
2	RED	32	ZONE_1
3	WHT	31	ZONE_2
4	GRN	30	ZONE_3
5	BLU	29	ZONE_4
6	YEL	28	ZONE_5
7	BRN	27	ZONE_6
8	ORG	26	ZONE_7
9	WHT	25	ZONE_8
11	BLACK	-	SHIELD

PAIR 1
PAIR 2
PAIR 3
PAIR 4
PAIR 5
PAIR 6
PAIR 7
PAIR 8

WIRING CHART			
PIN NUMBER J3 CONNECTOR	WIRE COLOR	PIN NUMBER 32-PIN CONNECTOR	DESCRIPTION
12	BLK	16	POWER
13	BLK	15	POWER
14	BLK	14	POWER
15	BLK	13	POWER
16	BLK	12	POWER
17	BLK	11	POWER
18	BLK	10	POWER
19	RED	9	POWER

WIRING CHART			
PIN NUMBER J4 CONNECTOR	WIRE COLOR	PIN NUMBER 32-PIN CONNECTOR	DESCRIPTION
2	RED	24	ZONE_9
3	WHT	23	ZONE_10
4	GRN	22	ZONE_11
5	BLU	21	ZONE_12
6	YEL	20	ZONE_13
7	BRN	19	ZONE_14
8	ORG	18	ZONE_15
9	WHT	17	ZONE_16
11	BLACK	-	SHIELD

PAIR 1
PAIR 2
PAIR 3
PAIR 4
PAIR 5
PAIR 6
PAIR 7
PAIR 8

WIRING CHART			
PIN NUMBER J4 CONNECTOR	WIRE COLOR	PIN NUMBER 32-PIN CONNECTOR	DESCRIPTION
12	BLK	8	POWER
13	BLK	7	POWER
14	BLK	6	POWER
15	BLK	5	POWER
16	BLK	4	POWER
17	BLK	3	POWER
18	BLK	2	POWER
19	RED	1	POWER

Chromapulse cables - multiple module types

Chromapulse umbilical camera module

Umbilical Camera Module 2* Camera Intellispec - Chromapulse

*Also use for single camera. In 1-camera applications, the Differential Control B cable is not present.

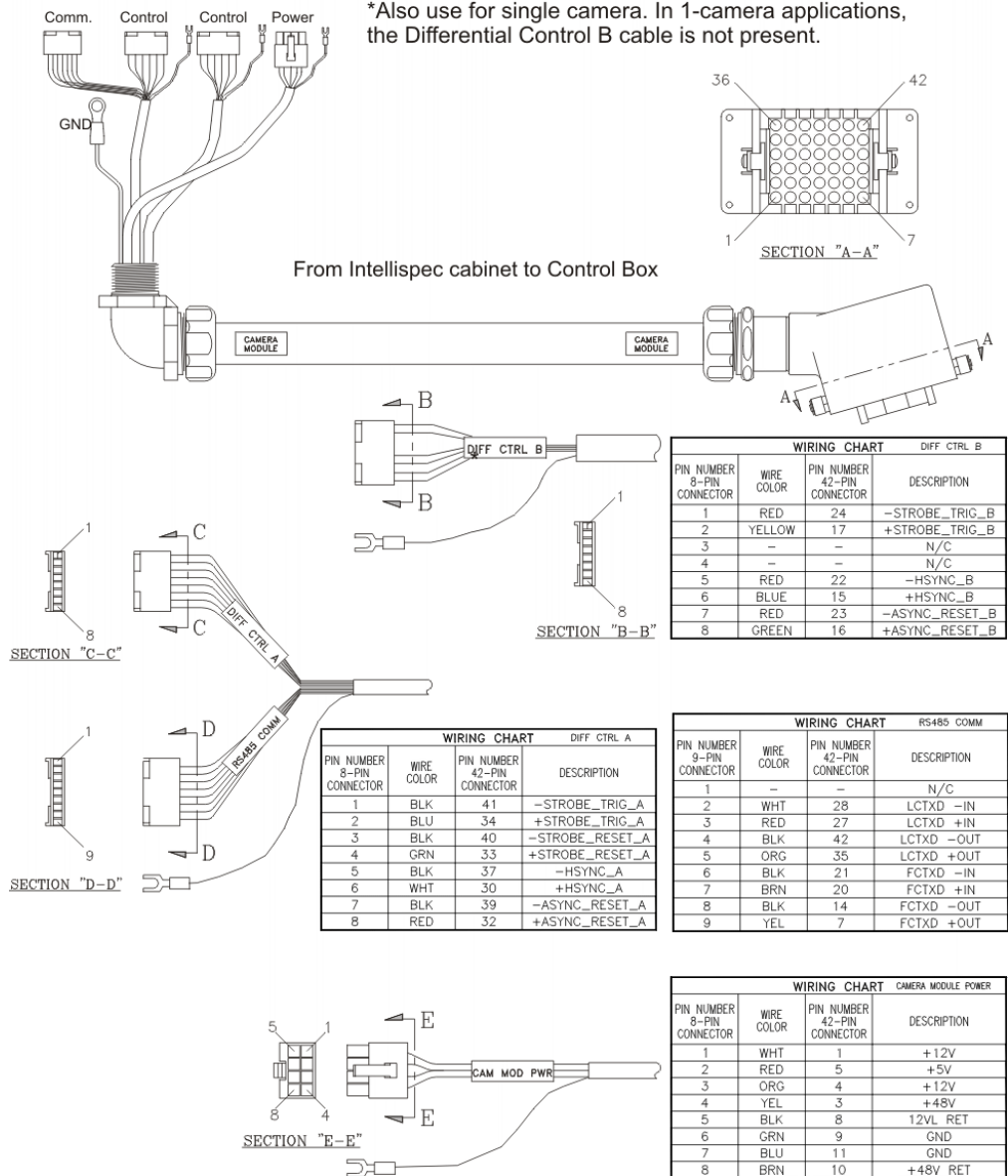

Umbilical camera module to cabinet - 1 camera

Camera Module Umbilical (1 camera)

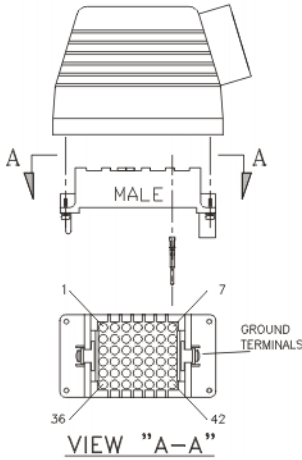
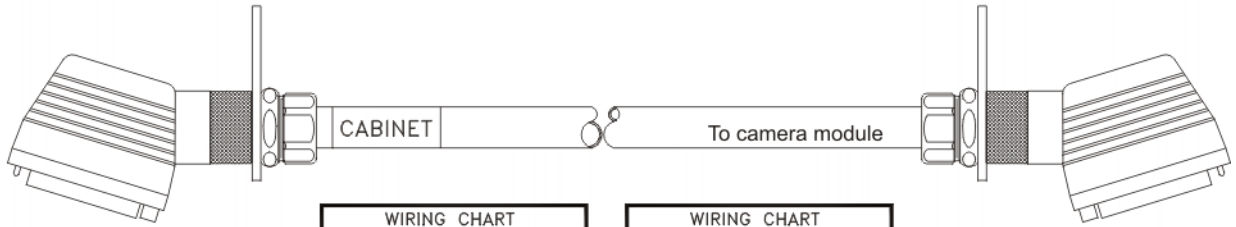

WIRING CHART	
PIN NO.	DESCRIPTION
1	+12L
2	N/C
3	+48V
4	+12V
5	+5V
6	N/C
7	3RS_485TXD+
8	+12LRET
9	GND
10	GND
11	GND
12	N/C
13	N/C
14	3RS_485-TXD-
15	N/C
16	N/C
17	N/C
18	N/C
19	N/C
20*	3RS_485-TXD+
21*	3RS_485-TXD-

WIRING CHART	
PIN NO.	DESCRIPTION
22	N/C
23	N/C
24	N/C
25	N/C
26	N/C
27**	4RS_485-TXD+
28**	4RS_485-TXD-
29	N/C
30	+Hsync_1
31	N/C
32	+Asynch_Reset_1
33	+Strobe_Reset_1
34	+Strobe_Trig_1
35	4RS_485-TXD+
36	N/C
37	-Hsync_1
38	N/C
39	-Asynch_Reset_1
40	-Strobe_Reset_1
41	-Strobe_Trig_1
42	4RS_485-TXD-

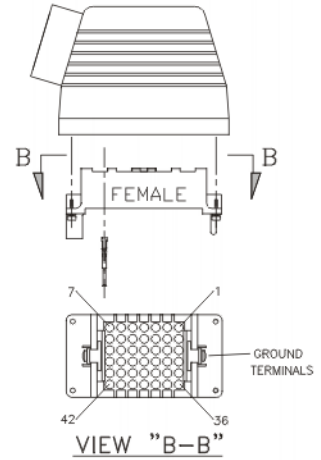

*-PINS 20 & 21 ARE RETURN LINES FOR 3RS COMM. SIGNALS.
 **-PINS 27 & 28 ARE RETURN LINES FOR 4RS COMM. SIGNALS.

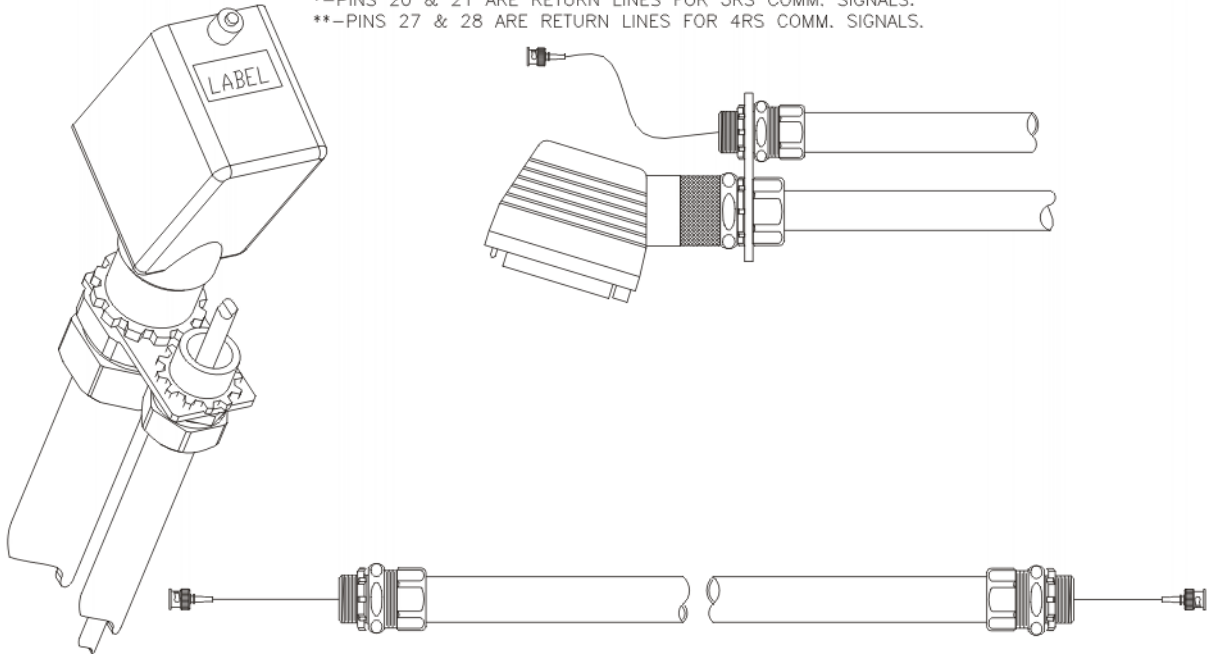

Umbilical camera module to cabinet - 2 camera

Camera Module Umbilical (2 camera)

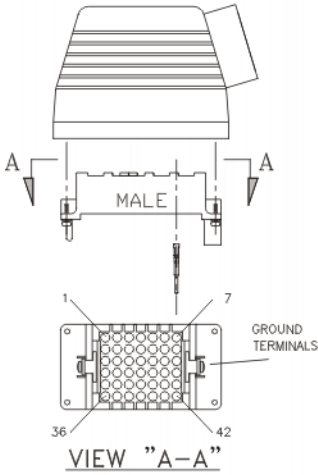
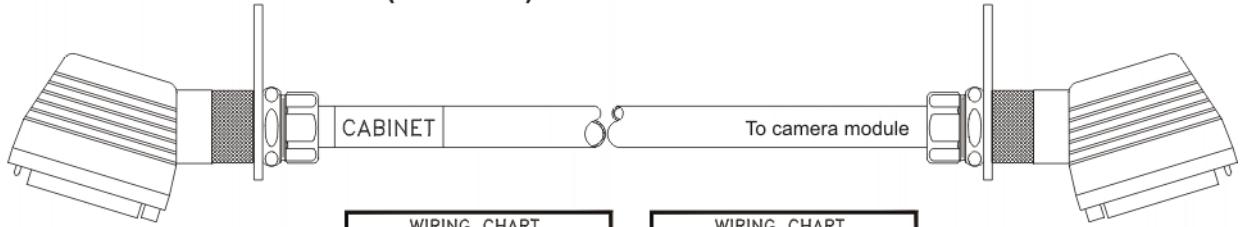

WIRING CHART	
PIN NO.	DESCRIPTION
1	+12L
2	N/C
3	+48V
4	+12V
5	+5V
6	N/C
7	FC_485+
8	+12LRET
9	GND
10	GND
11	GND
12	N/C
13	N/C
14	FC_485-
15	+Hsync_2
16	+Async_Reset_2
17	+Strobe_Trig_2
18	N/C
19	N/C
20	FC_485+ RET
21	FC_485- RET

WIRING CHART	
PIN NO.	DESCRIPTION
22	-Hsync_2
23	-Async_Reset_2
24	-Strobe_Trig_2
25	N/C
26	N/C
27	LC_485+ RET
28	LC_485- RET
29	N/C
30	+Hsync_1
31	N/C
32	+Async_Reset_1
33	+Strobe_Reset_1
34	+Strobe_Trig_1
35	LC_485+
36	N/C
37	-Hsync_1
38	N/C
39	-Async_Reset_1
40	-Strobe_Reset_1
41	-Strobe_Trig_1
42	LC_485-

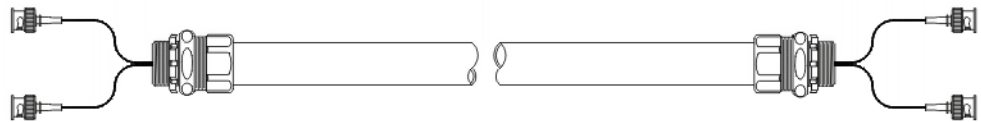
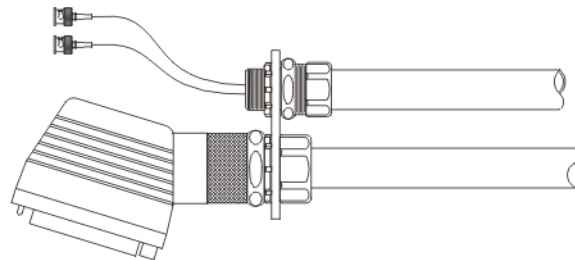
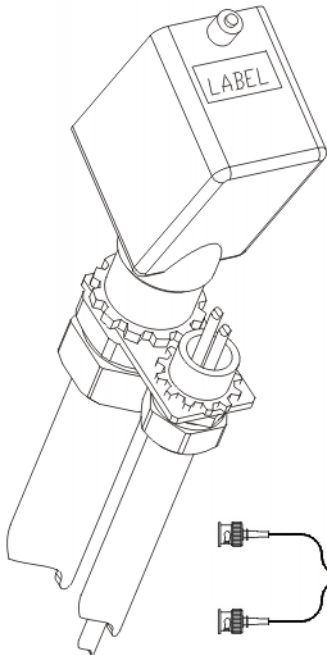
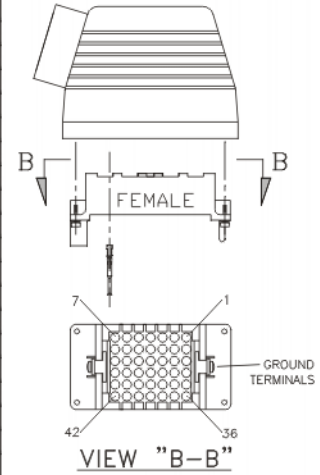

Umbilical video 1 CAT6 S IV-D

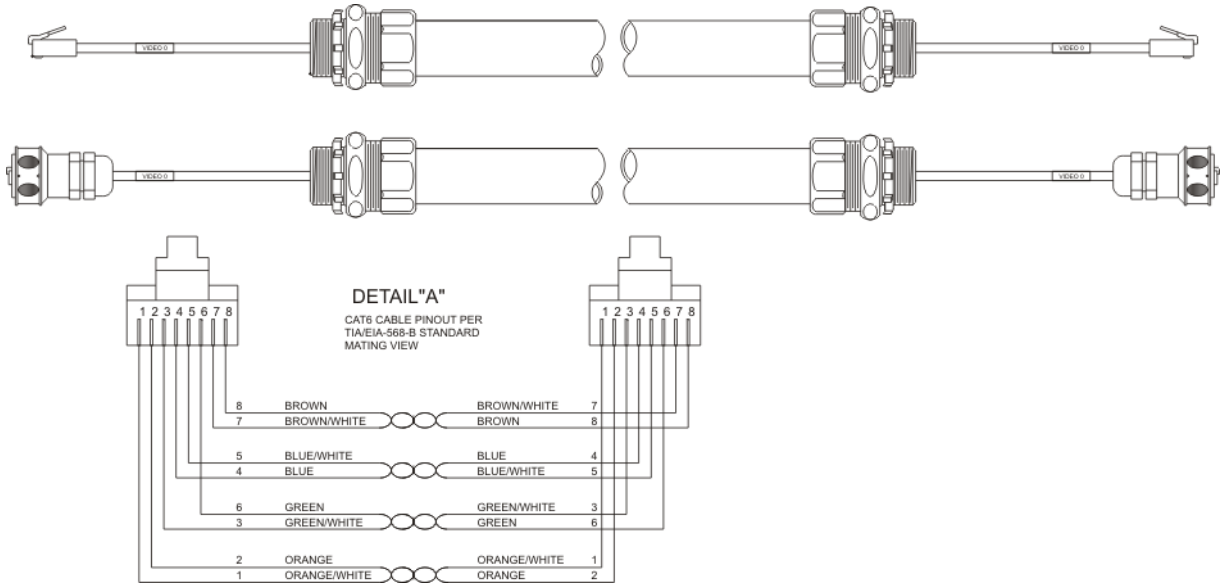

Umbilical video 2 CAT6 S IV-D

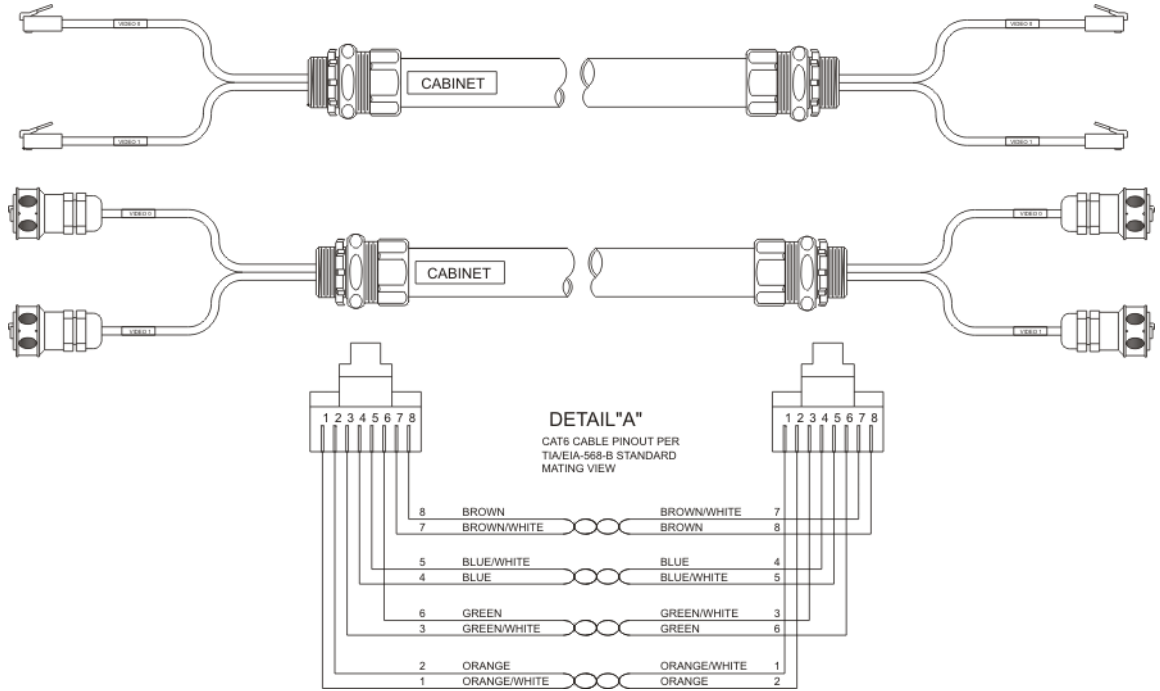

Umbilical video 1 CAT6 S IV-D braided

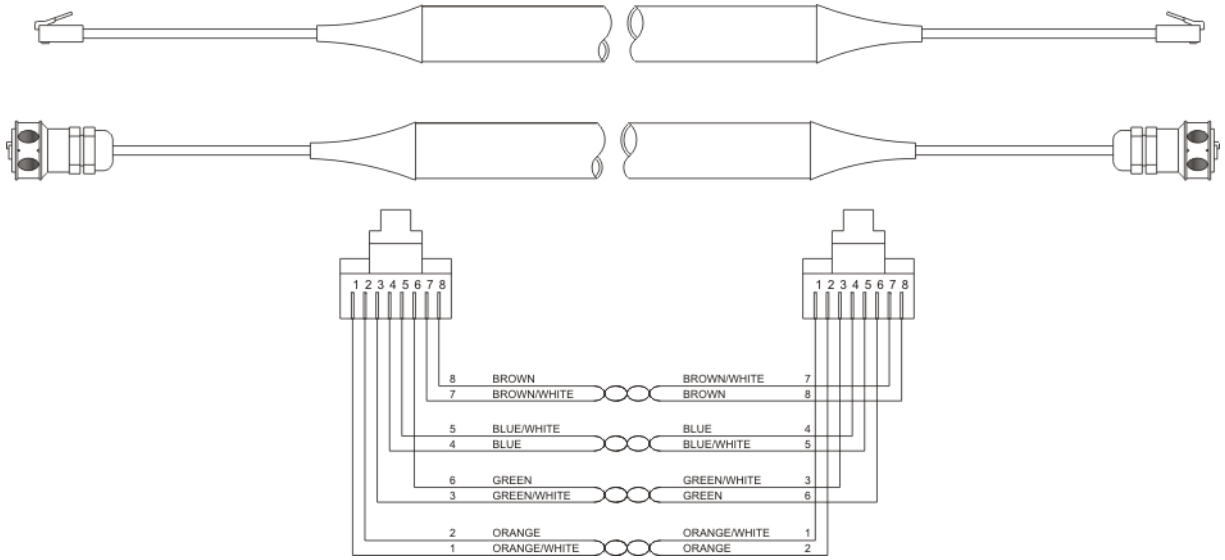

Umbilical video 4 CAT6 S IV-D+

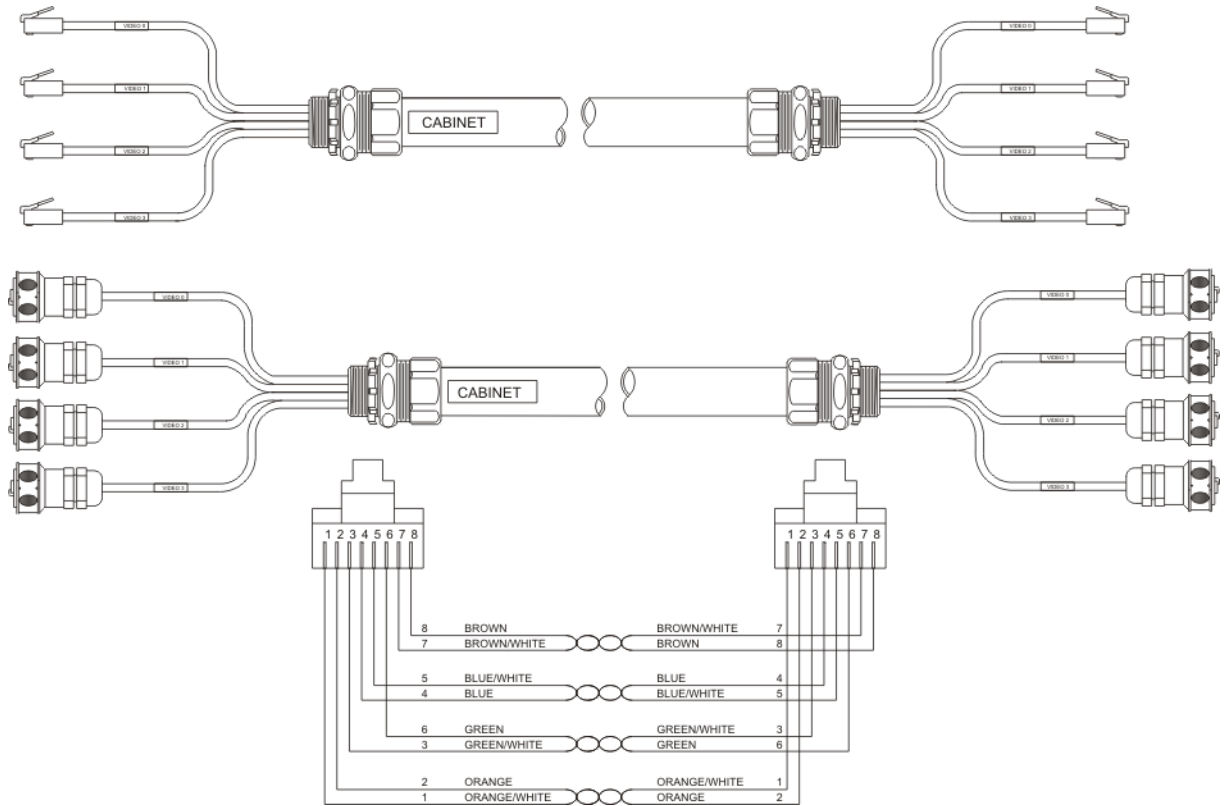

58010 Cable video CAT6 S IV-D

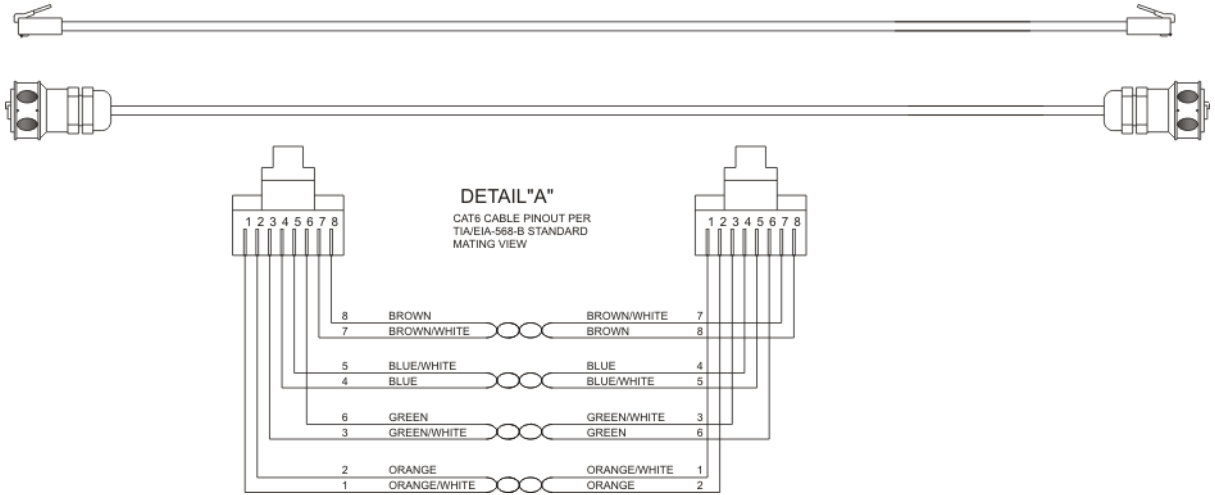

59608 Umbilical video CAT6 Filling S IV-D

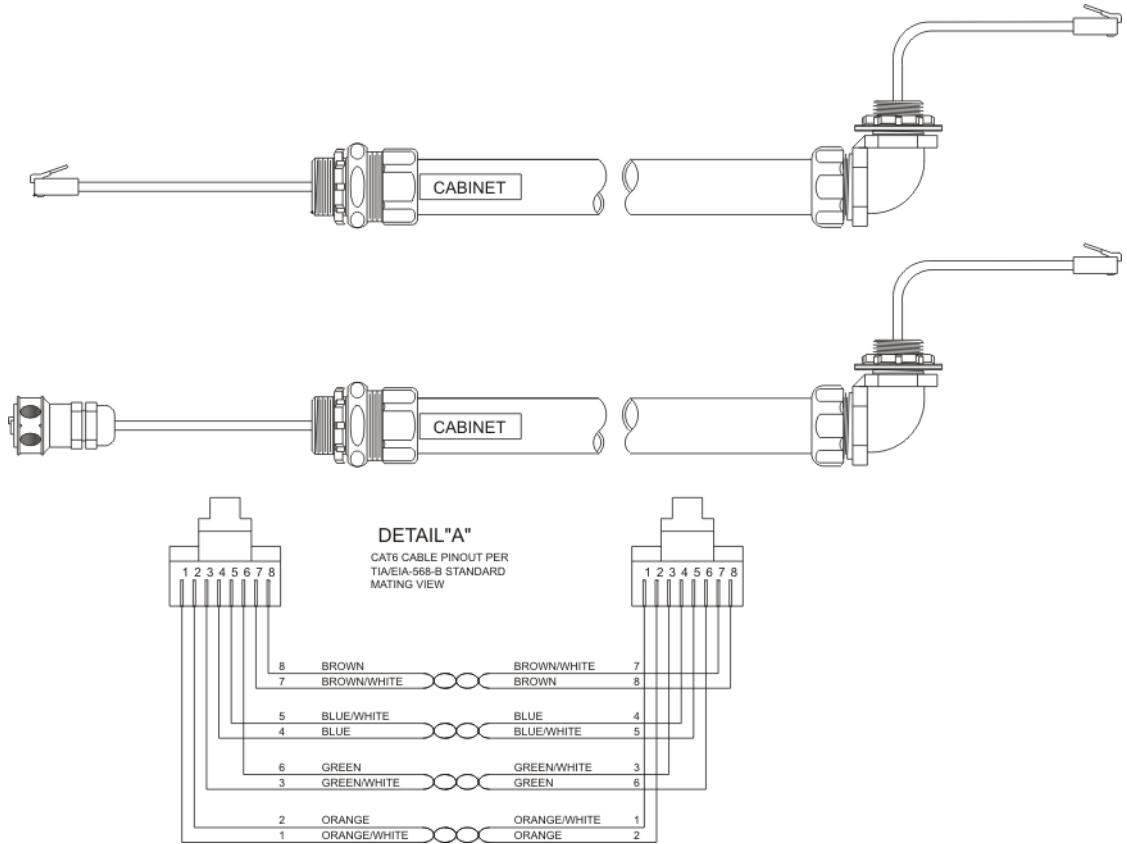

Umbilical 1 camera/ 1 video S IV-D

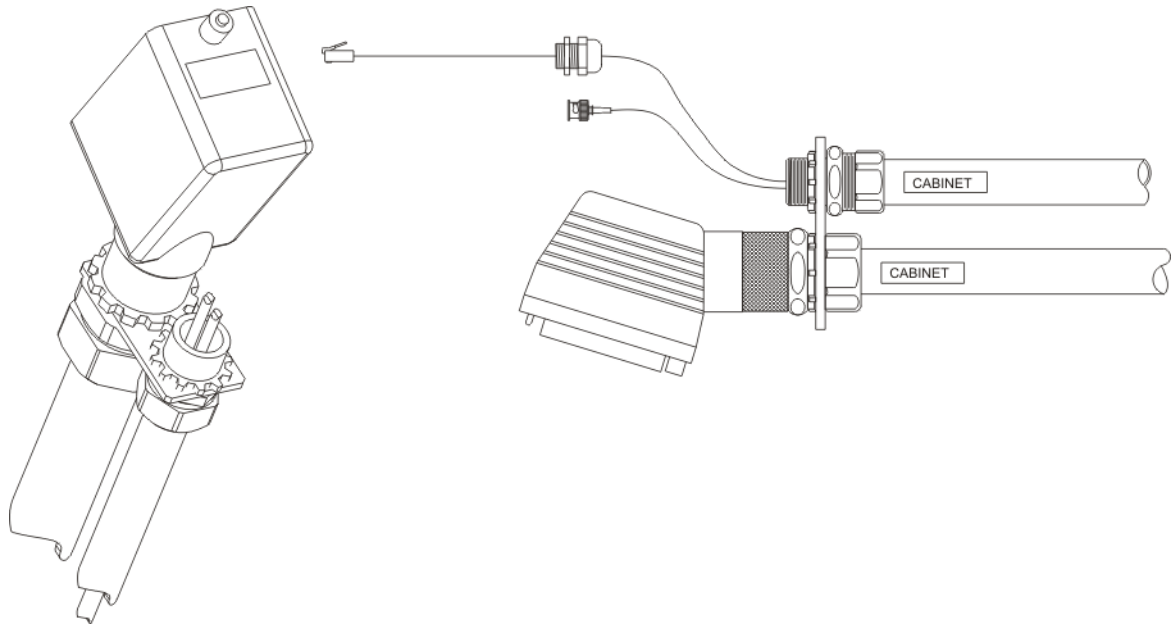

Umbilical 1 camera/ 1 CAT6 S IV-D

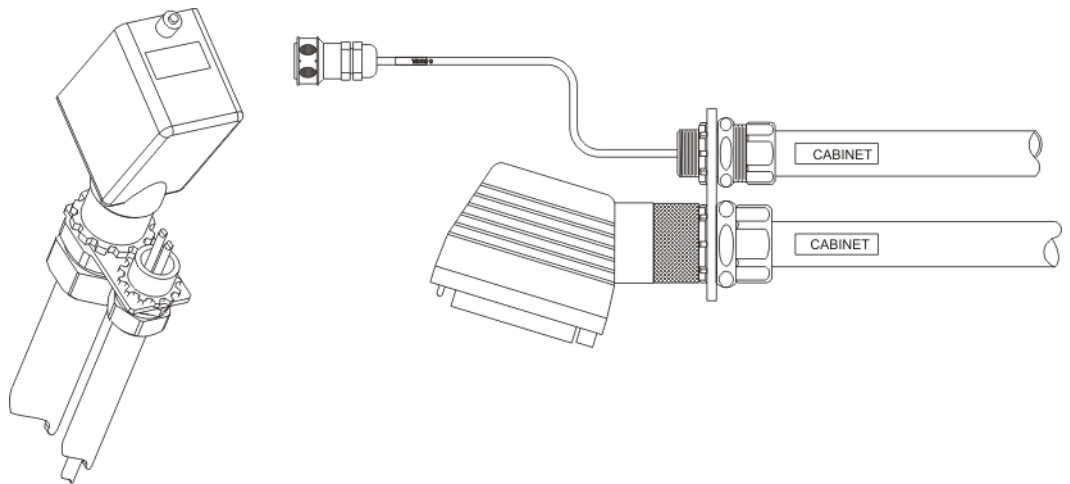

Umbilical 1 camera/ 1 CAT6 S IV-D braided

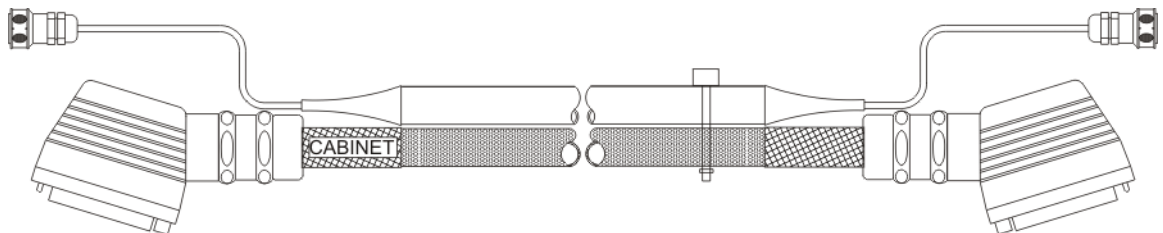

Umbilical 2 camera/ 2 video S IV-D

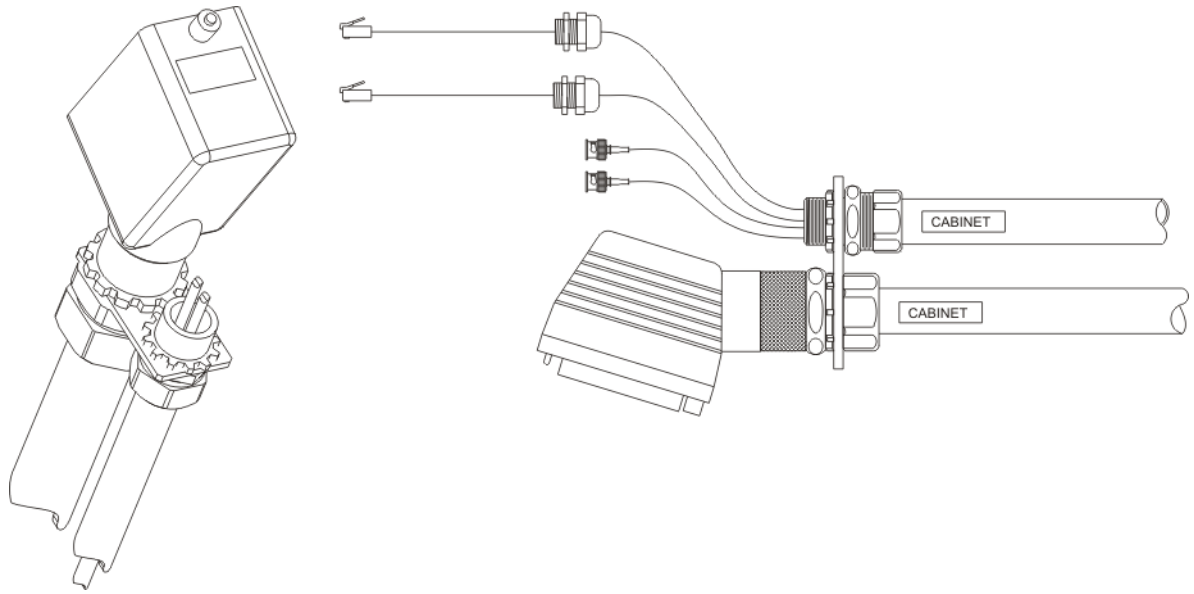

Umbilical 2 camera/ 2 CAT6 S IV-D

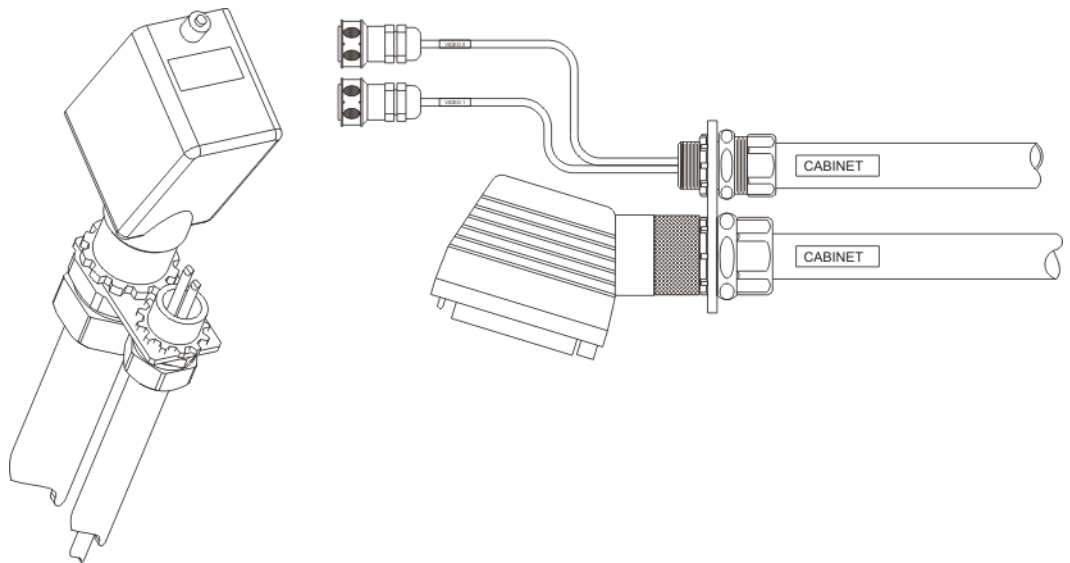

Umbilical 1 camera/ 2 CAT6 S IV-D+

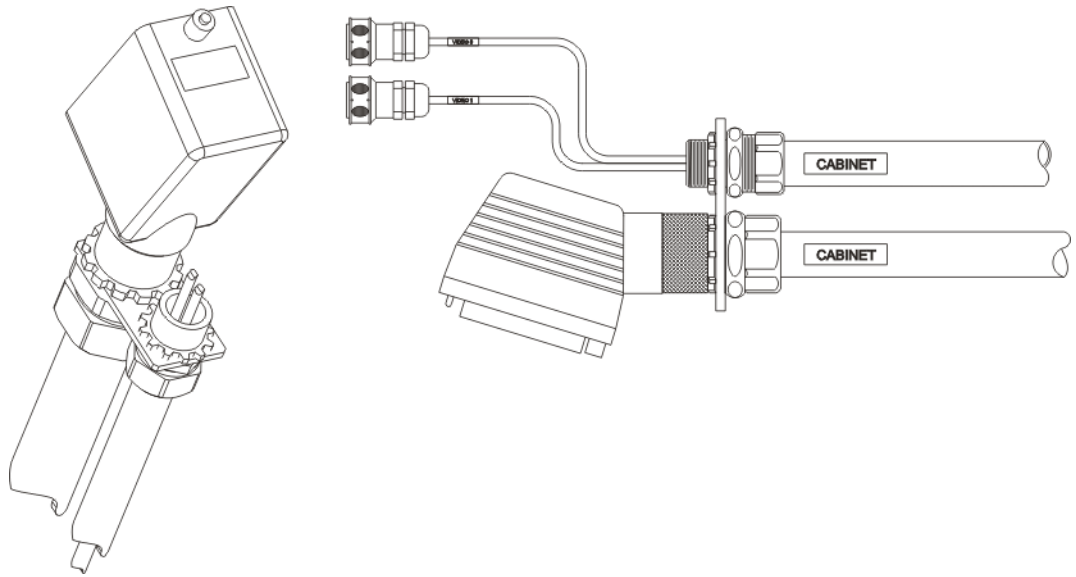

Umbilical 2 camera/ 4 video S IV-D+

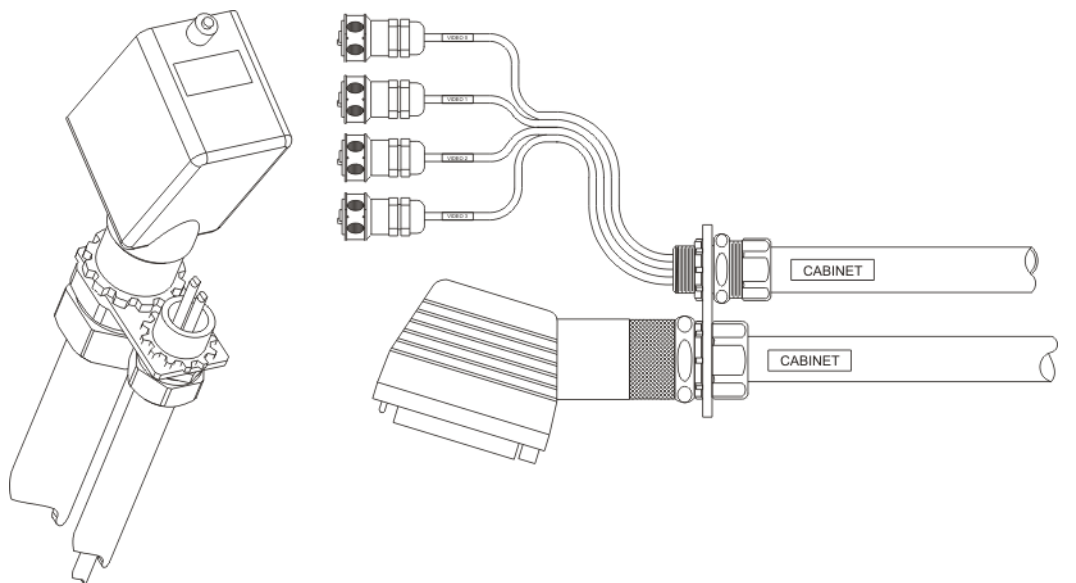

GIG-E camera control CP right-angle

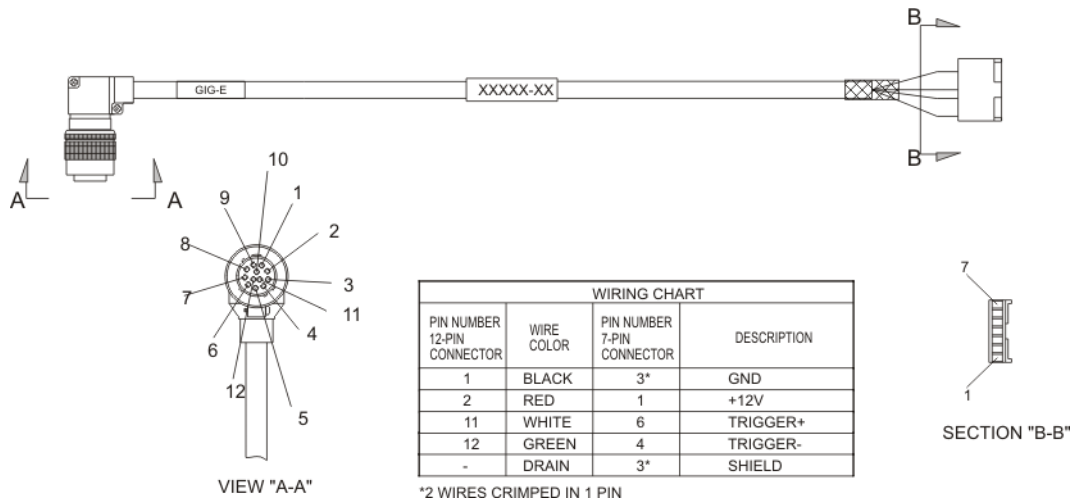

Cable camera module 2cam S4 53610

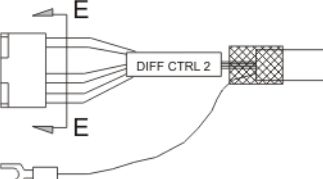
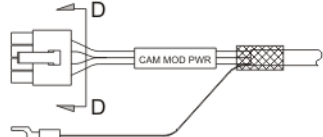
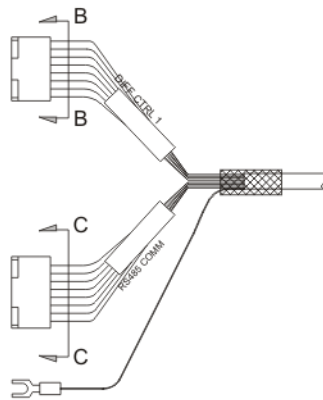
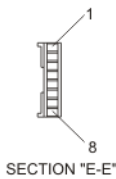
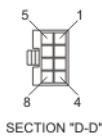
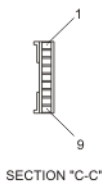
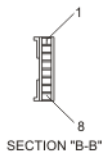
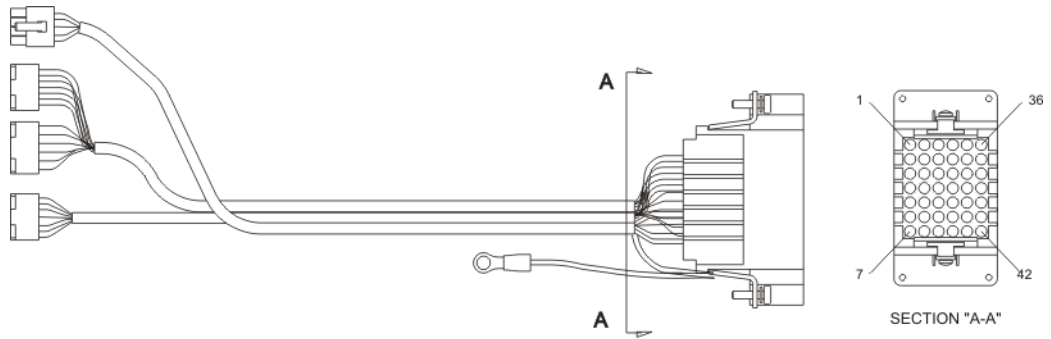

WIRING CHART		DIFF CTRL 1	
PIN NUMBER 8-PIN CONNECTOR	WIRE COLOR	PIN NUMBER 42-PIN CONNECTOR	DESCRIPTION
1	BLK	41	-STROBE_TRIG_1
2	BLU	34	+STROBE_TRIG_1
3	BLK	40	-STROBE_RESET
4	GRN	33	+STROBE_RESET
5	BLK	37	-HSYNC_1
6	WHT	30	+HSYNC_1
7	BLK	39	-ASYNC_RESET_1
8	RED	32	+ASYNC_RESET_1

WIRING CHART		RS485 COMM	
PIN NUMBER 9-PIN CONNECTOR	WIRE COLOR	PIN NUMBER 42-PIN CONNECTOR	DESCRIPTION
1	-	-	N/C
2	WHT	28	LCTXD -IN
3	RED	27	LCTXD +IN
4	BLK	42	LCTXD -OUT
5	ORG	35	LCTXD +OUT
6	BLK	21	FCTXD -IN
7	BRN	20	FCTXD +IN
8	BLK	14	FCTXD -OUT
9	YEL	7	FCTXD +OUT

WIRING CHART		CAMERA MODULE POWER	
PIN NUMBER 8-PIN CONNECTOR	WIRE COLOR	PIN NUMBER 42-PIN CONNECTOR	DESCRIPTION
1	WHT	1	+12V
2	RED	5	+5V
3	ORG	4	+12V
4	YEL	3	+48V
5	BLK	8	12VL RET
6	GRN	9	GND
7	BLU	11	GND
8	BRN	10	+48V RET

WIRING CHART		DIFF CTRL 2	
PIN NUMBER 8-PIN CONNECTOR	WIRE COLOR	PIN NUMBER 42-PIN CONNECTOR	DESCRIPTION
1	BLK	24	-STROBE_TRIG_2
2	GRN	17	+STROBE_TRIG_2
3	-	-	N/C
4	-	-	N/C
5	BLK	22	-HSYNC_2
6	WHT	15	+HSYNC_2
7	BLK	23	-ASYNC_RESET_2
8	RED	16	+ASYNC_RESET_2

58371 GIG-E camera control CP 8ft. cord grip

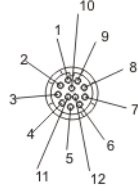

SECTION "A-A"
ENLARGED

WIRING CHART			
PIN NUMBER 12-PIN CONNECTOR	WIRE COLOR	PIN LETTER 6-PIN CONNECTOR	DESCRIPTION
1	BLACK	B	GND
2	RED	A	+12V IN
11	WHITE	C	TRIGGER+
12	GREEN	D	TRIGGER-

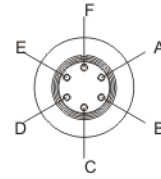

VIEW "B-B"

Cable wiring diagrams CP/E modules

52189 Camera module umbilical

Camera module Series 2+ internal

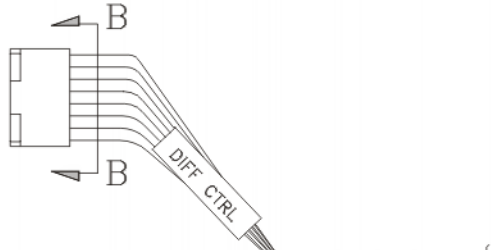
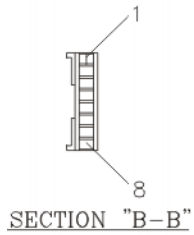

WIRING CHART		DIFF CTRL	
PIN NUMBER 8-PIN CONNECTOR	WIRE COLOR	PIN NUMBER 42-PIN CONNECTOR	DESCRIPTION
1	BLK	41	-STROBE_TRIG
2	BLU	34	+STROBE_TRIG
3	BLK	40	-STROBE_RESET
4	GRN	33	+STROBE_RESET
5	BLK	37	-HSYNC
6	WHT	30	+HSYNC
7	BLK	39	-ASYNC_RESET
8	RED	32	+ASYNC_RESET

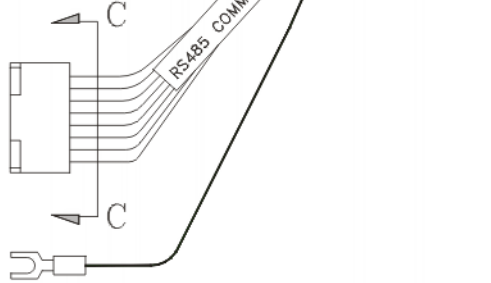
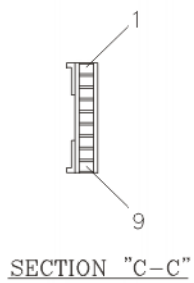

WIRING CHART		RS485 COMM	
PIN NUMBER 9-PIN CONNECTOR	WIRE COLOR	PIN NUMBER 42-PIN CONNECTOR	DESCRIPTION
1	-	-	N/C
2	WHT	28	LCTXD -IN
3	RED	27	LCTXD +IN
4	BLK	42	LCTXD -OUT
5	ORG	35	LCTXD +OUT
6	BLK	21	FCTXD -IN
7	BRN	20	FCTXD +IN
8	BLK	14	FCTXD -OUT
9	YEL	7	FCTXD +OUT

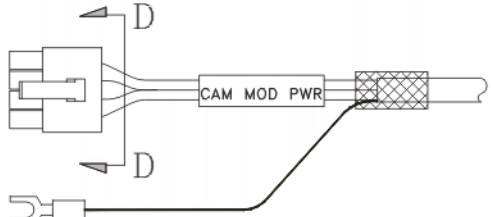
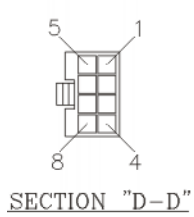

WIRING CHART		CAMERA MODULE POWER	
PIN NUMBER 8-PIN CONNECTOR	WIRE COLOR	PIN NUMBER 42-PIN CONNECTOR	DESCRIPTION
1	WHT	1	+12V
2	RED	5	+5V
3	ORG	4	+12V
4	YEL	3	+48V
5	BLK	8	12VL RET
6	GRN	9	GND
7	BLU	11	GND
8	BRN	10	+48V RET

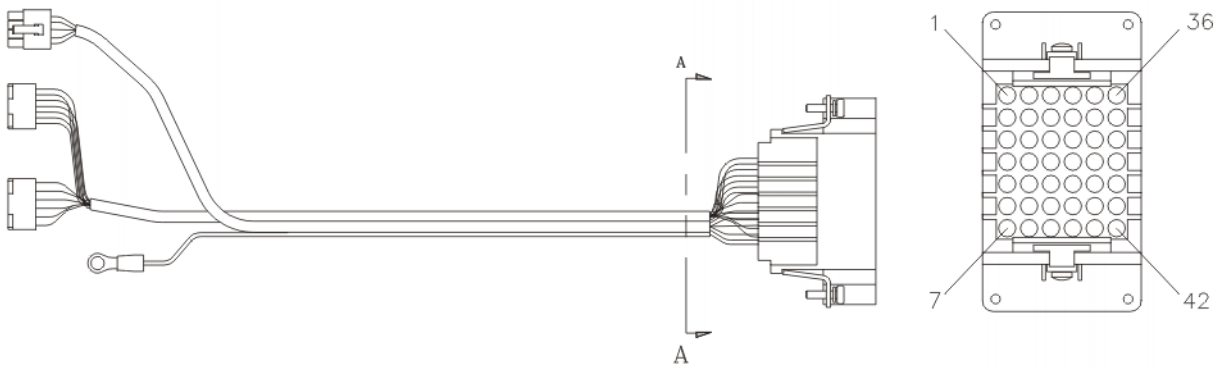

2 camera module umbilical

Camera module 2 camera Series IV

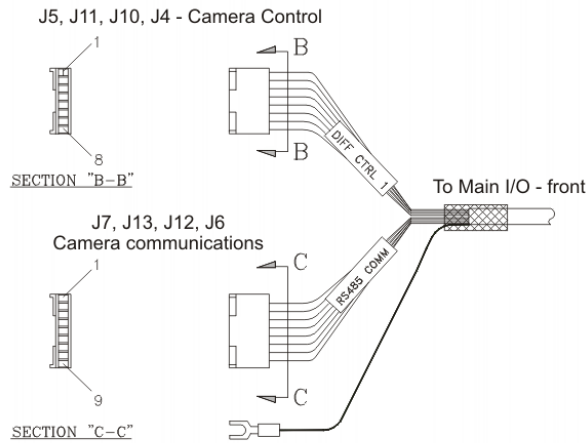
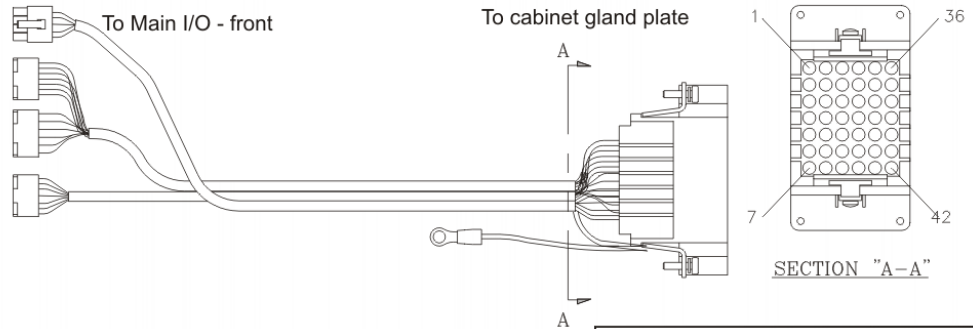

WIRING CHART				DIFF CTRL 1
PIN NUMBER 8-PIN CONNECTOR	WIRE COLOR	PIN NUMBER 42-PIN CONNECTOR	DESCRIPTION	
1	BLK	41	-STROBE_TRIG_1	
2	BLU	34	+STROBE_TRIG_1	
3	BLK	40	-STROBE_RESET	
4	GRN	33	+STROBE_RESET	
5	BLK	37	-HSYNC_1	
6	WHT	30	+HSYNC_1	
7	BLK	39	-ASYNC_RESET_1	
8	RED	32	+ASYNC_RESET_1	

WIRING CHART				RS485 COMM
PIN NUMBER 9-PIN CONNECTOR	WIRE COLOR	PIN NUMBER 42-PIN CONNECTOR	DESCRIPTION	
1	-	-	N/C	
2	WHT	28	LCTXD -IN	
3	RED	27	LCTXD +IN	
4	BLK	42	LCTXD -OUT	
5	ORG	35	LCTXD +OUT	
6	BLK	21	FCTXD -IN	
7	BRN	20	FCTXD +IN	
8	BLK	14	FCTXD -OUT	
9	YEL	7	FCTXD +OUT	

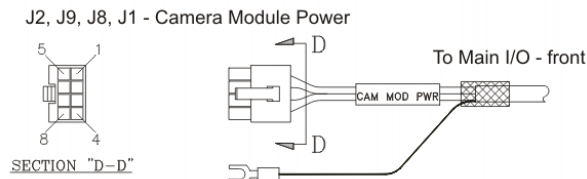

WIRING CHART				CAMERA MODULE POWER
PIN NUMBER 8-PIN CONNECTOR	WIRE COLOR	PIN NUMBER 42-PIN CONNECTOR	DESCRIPTION	
1	WHT	1	+12V	
2	RED	5	+5V	
3	ORG	4	+12V	
4	YEL	3	+48V	
5	BLK	8	12VL RET	
6	GRN	9	GND	
7	BLU	11	GND	
8	BRN	10	+48V RET	

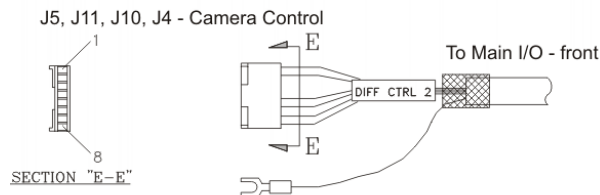

WIRING CHART				DIFF CTRL 2
PIN NUMBER 8-PIN CONNECTOR	WIRE COLOR	PIN NUMBER 42-PIN CONNECTOR	DESCRIPTION	
1	BLK	24	-STROBE_TRIG_2	
2	GRN	17	+STROBE_TRIG_2	
3	-	-	N/C	
4	-	-	N/C	
5	BLK	22	-HSYNC_2	
6	WHT	15	+HSYNC_2	
7	BLK	23	-ASYNC_RESET_2	
8	RED	16	+ASYNC_RESET_2	

54132 CP/E 9 zone main, 4 zone fill, 3 zone ring

CP/E modules 9 zone Main array/ 4 zone Fill array/ 3 zone Ring array

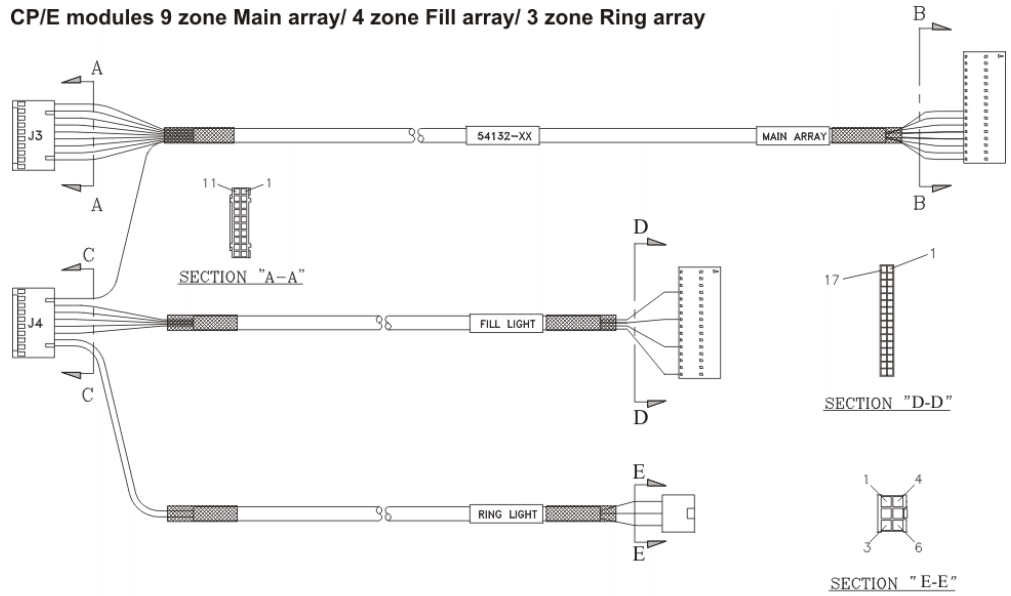

WIRING DIAGRAM

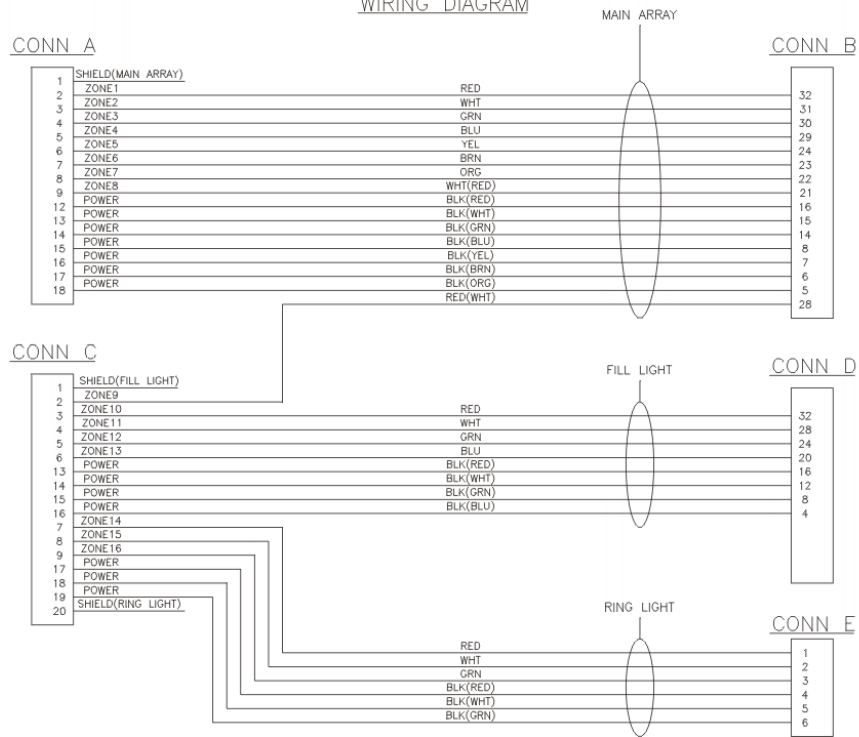

54133 CP/E 9 zone main, 4 zone fill, 3 zone ring

CP/E modules 9 zone Main array/ 4 zone Fill array/ 3 zone Ring array

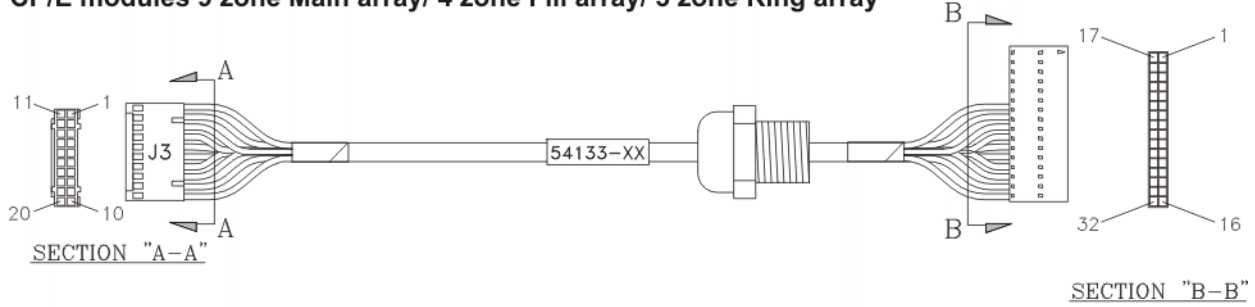

WIRING CHART			
PIN NUMBER 20-PIN CONNECTOR	WIRE COLOR	PIN NUMBER 32-PIN CONNECTOR	DESCRIPTION
2	RED	32	ZONE_1
3	WHT	31	ZONE_2
4	GRN	30	ZONE_3
5	BLU	29	ZONE_4
6	YEL	24	ZONE_5
7	BRN	23	ZONE_6
8	ORG	22	ZONE_7
9	WHT	21	ZONE_8
11	BLACK	-	SHIELD

WIRING CHART			
PIN NUMBER 20-PIN CONNECTOR	WIRE COLOR	PIN NUMBER 32-PIN CONNECTOR	DESCRIPTION
12	BLK	16	POWER
13	BLK	15	POWER
14	BLK	14	POWER
15	BLK	13	POWER
16	BLK	8	POWER
17	BLK	7	POWER
18	BLK	6	POWER
19	RED	5	POWER

54549 CP/E dual 3 zone lower array

CP/E modules dual 3 zone Lower array

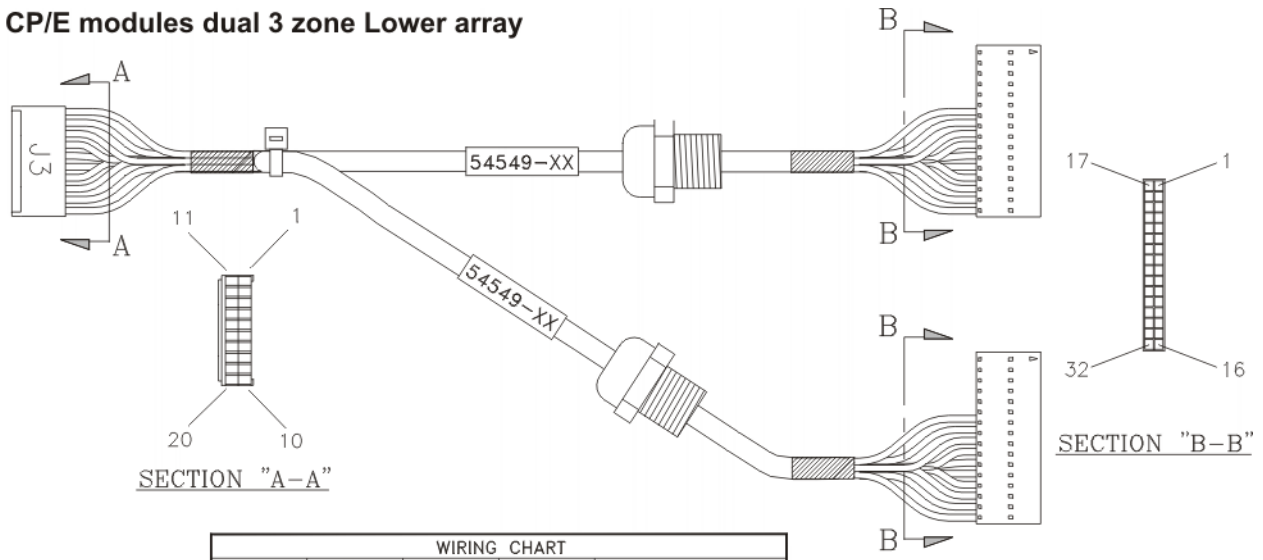

WIRING CHART				
J3 CONNECTOR	NO CONNECTOR	ARRAY CONNECTOR ONE	ARRAY CONNECTOR TWO	WIRE COLOR
2	-	32	32	RED
3	-	31	31	WHT
4	-	30	30	GRN
5	-	29	29	BLU
6	-	24	24	YEL
7	-	23	23	BRN
8	-	22	22	ORG
9	-	21	21	WHT(RED)
10	-	-	-	SHIELD (CONN 1)
12	-	16	16	BLACK(RED)
13	-	15	15	BLACK(WHT)
14	-	14	14	BLACK(GRN)
15	-	13	13	BLACK(BLU)
16	-	8	8	BLACK(YEL)
17	-	7	7	BLACK(BRN)
18	-	6	6	BLACK(ORG)
19	-	5	5	RED(WHT)
20	-	-	-	SHIELD (CONN 2)

54525 lane sensors reject out Ultra I/O

Lane sensors reject out Ultra I/O

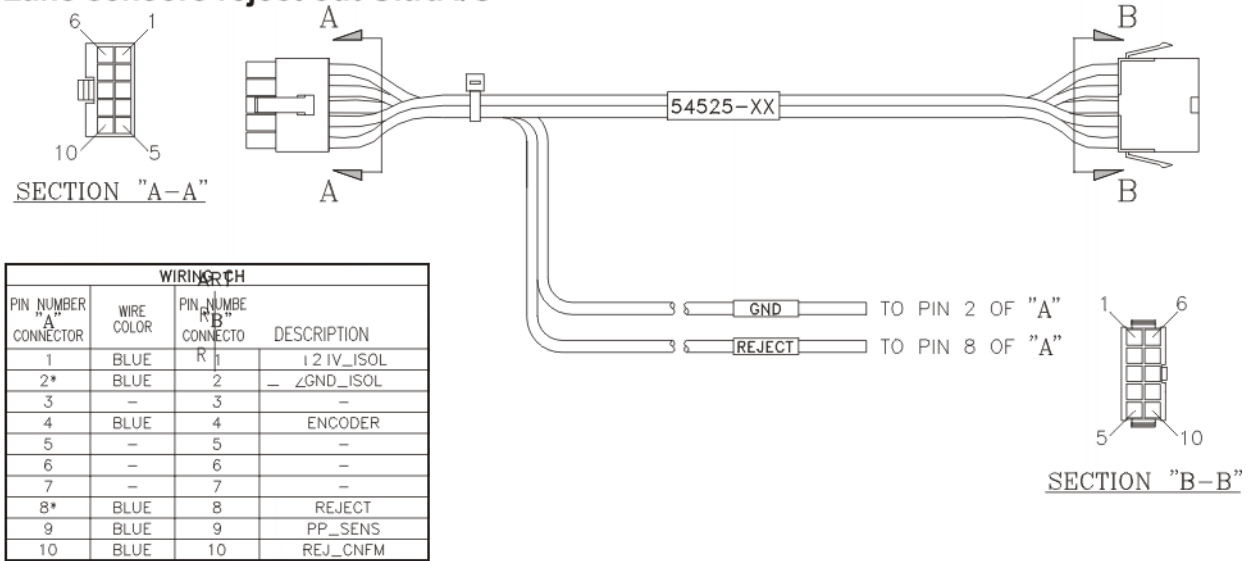

* TWO WIRES ARE CRIMPED IN EACH PIN.

54790 camera control neck module

Camera control neck module

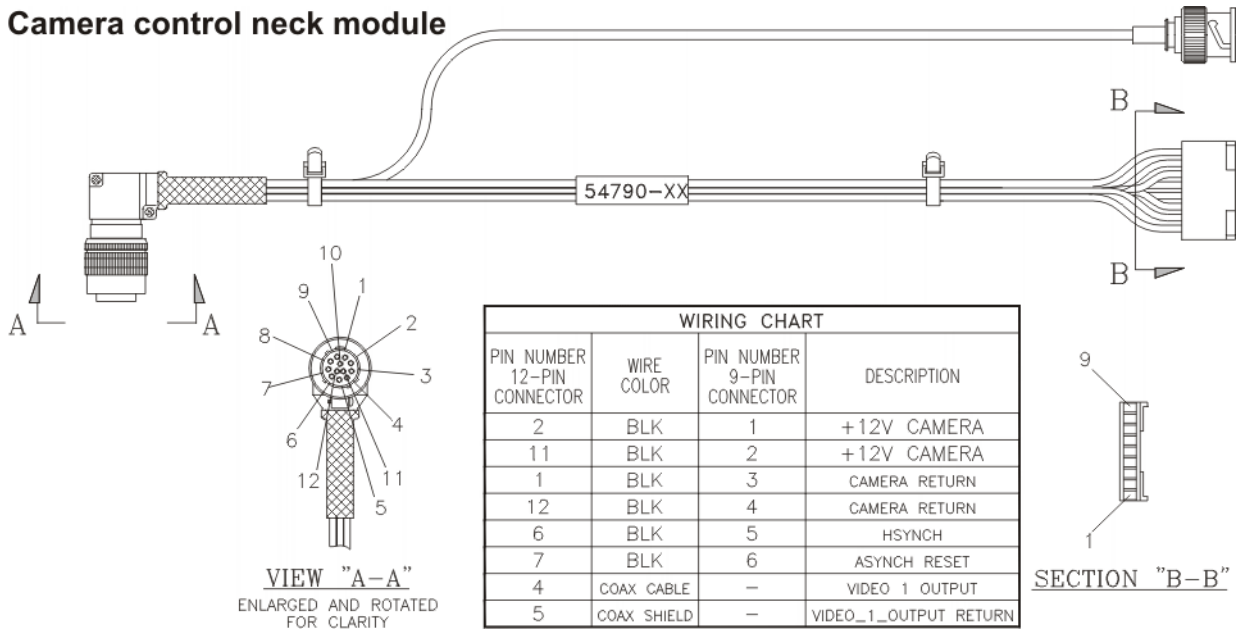

55314 CP/E 3 zone aux

CP/ E 3Z Aux

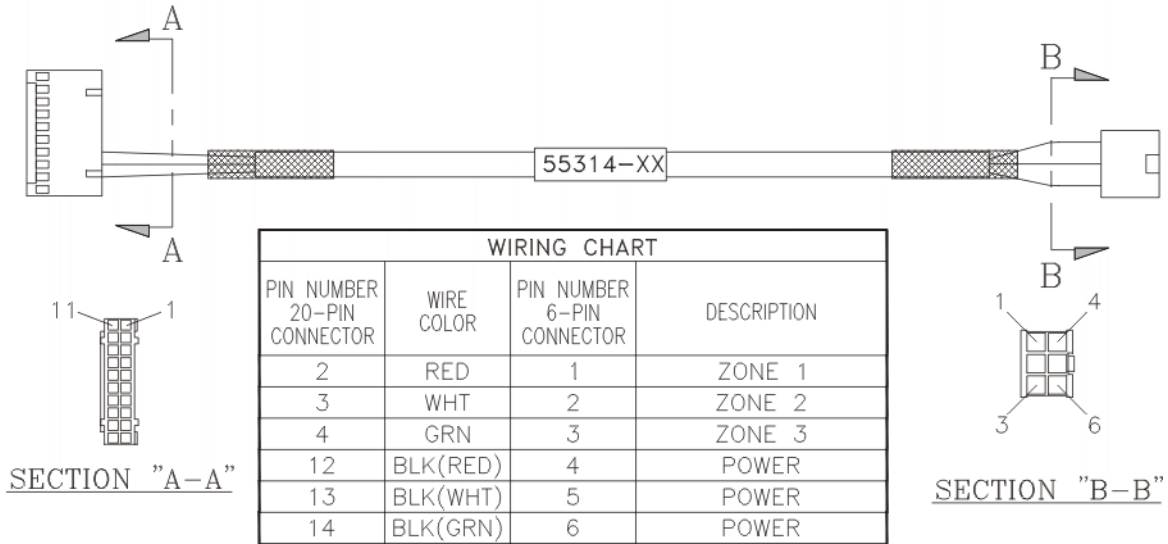

50322 array control 16 zones

Array control 16 zones

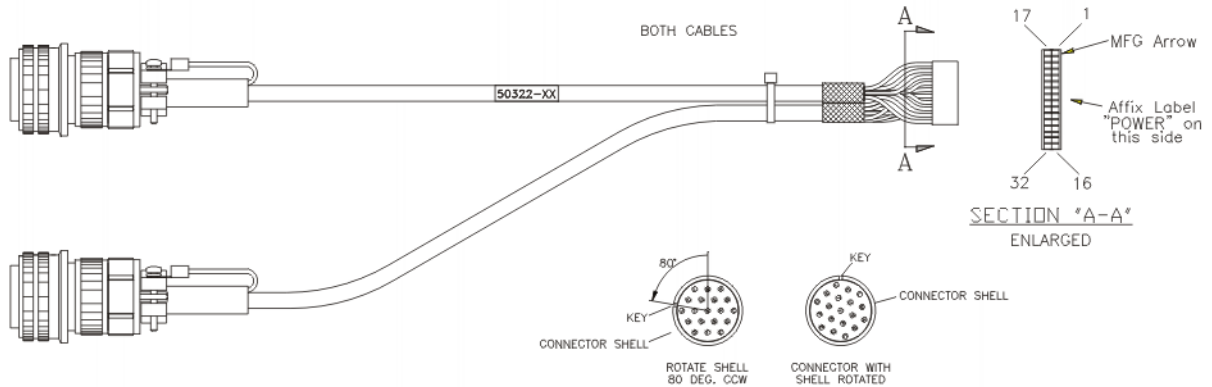

WIRING CHART		
PIN LETTER 19-PIN 'B' CONNECTOR	WIRE COLOR	PIN NUMBER 32-PIN 'A' CONNECTOR
A	RED	32
B	WHT	31
C	GRN	30
D	BLU	29
E	YEL	28
F	BRN	27
G	ORG	26
H	RED	25

WIRING CHART		
PIN LETTER 19-PIN 'B' CONNECTOR	WIRE COLOR	PIN NUMBER 32-PIN 'A' CONNECTOR
J	BLK	16
K	BLK	15
L	BLK	14
M	BLK	13
N	BLK	12
P	BLK	11
R	BLK	10
S	WHT	9

WIRING CHART		
PIN LETTER 19-PIN 'C' CONNECTOR	WIRE COLOR	PIN NUMBER 32-PIN 'A' CONNECTOR
A	RED	24
B	WHT	23
C	GRN	22
D	BLU	21
E	YEL	20
F	BRN	19
G	ORG	18
H	RED	17

WIRING CHART		
PIN LETTER 19-PIN 'C' CONNECTOR	WIRE COLOR	PIN NUMBER 32-PIN 'A' CONNECTOR
J	BLK	8
K	BLK	7
L	BLK	6
M	BLK	5
N	BLK	4
P	BLK	3
R	BLK	2
S	WHT	1

54230 ringlight 2 zones

Ringlight 2 zones

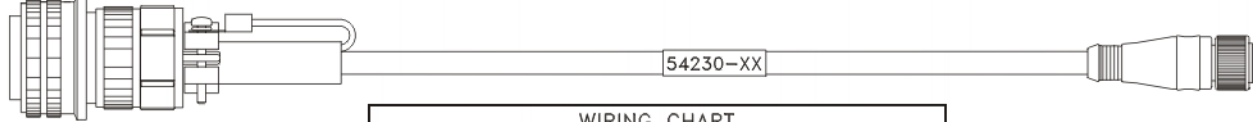

WIRING CHART			
PIN LETTER 10-PIN CONNECTOR	WIRE COLOR	PIN NUMBER 4-PIN CONNECTOR	DESCRIPTION
E	BRN	1	ZONE 1
F	WHT	2	ZONE 2
G	BLU	3	POWER
H	BLK	4	POWER

ZONE 1 IS TRIGGERED BY ARRAY DRIVER BD CONN ZONE 6.
ZONE 2 IS TRIGGERED BY ARRAY DRIVER BD CONN ZONE 7.

54305 DB37M - DB9M

DB37M - DB9M

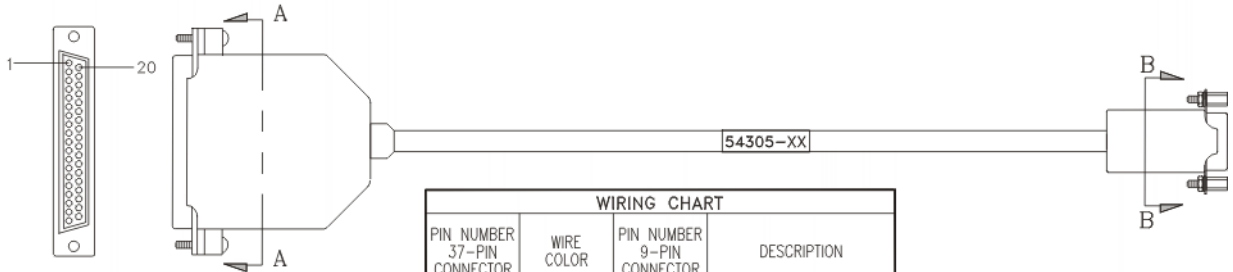

SECTION "A-A"

WIRING CHART			
PIN NUMBER 37-PIN CONNECTOR	WIRE COLOR	PIN NUMBER 9-PIN CONNECTOR	DESCRIPTION
11	BLK	1	DCD
12	BRN	5	GND
13	YEL	8	CTS
14	WHT	2	RXD
29	VIO	9	RI
30	GRN	4	DTR
31	BLU	6	DSR
32	ORG	7	RTS
33	RED	3	TXD

SECTION "B-B"

PET CAMERA MODULE CABLES

Array power/ 485 out PET

43912

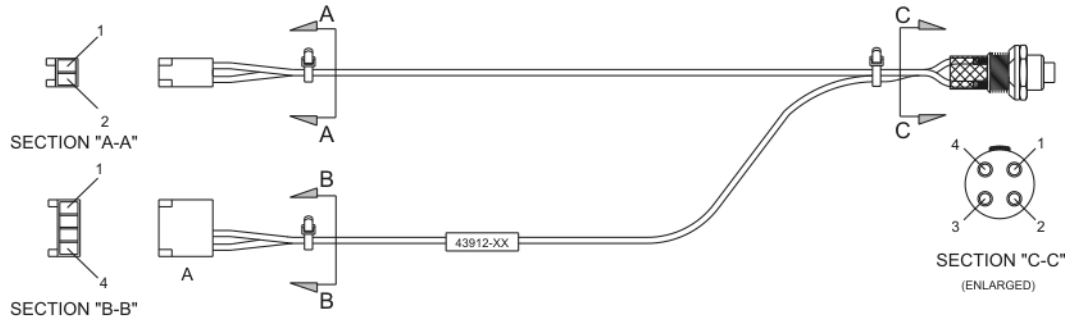

WIRING CHART				
PIN NUMBER 4-PIN 'B' CONNECTOR	WIRE COLOR	PIN NUMBER 4-PIN 'A' CONNECTOR	PIN NUMBER 2-PIN CONNECTOR	DESCRIPTION
1	BLK	4	-	+48V
2	WHT	3	-	48V RET
3	ORG	-	1	+RS485
4	RED	-	2	-RS485

Array power/ 485 out PPR2

56920

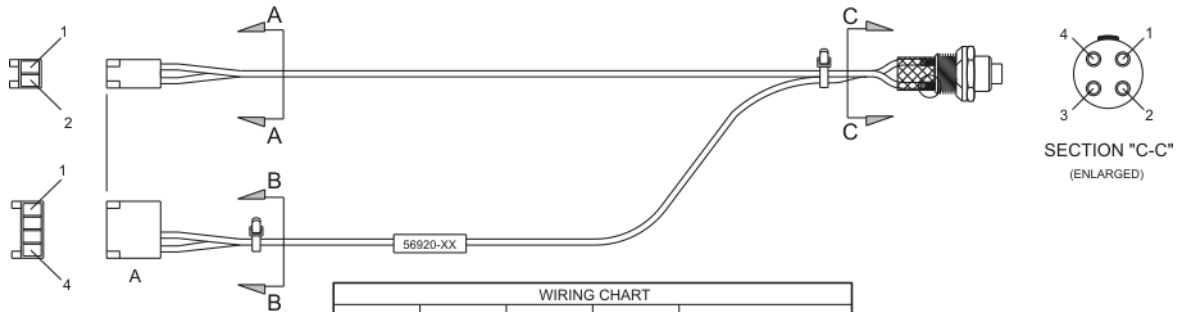

WIRING CHART				
PIN NUMBER 4-PIN 'B' CONNECTOR	WIRE COLOR	PIN NUMBER 4-PIN 'A' CONNECTOR	PIN NUMBER 2-PIN CONNECTOR	DESCRIPTION
1	BLK	4	-	+48V
2	WHT	3	-	48V RET
3	ORG	-	1	+RS485
4	RED	-	2	-RS485

LED control PET camera module

43914

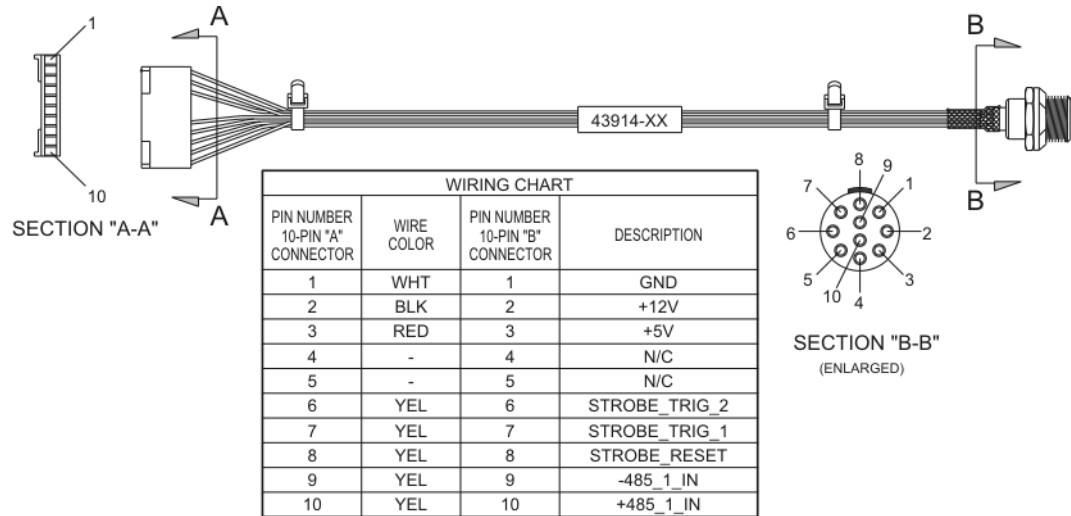

LED control PPR2

56880

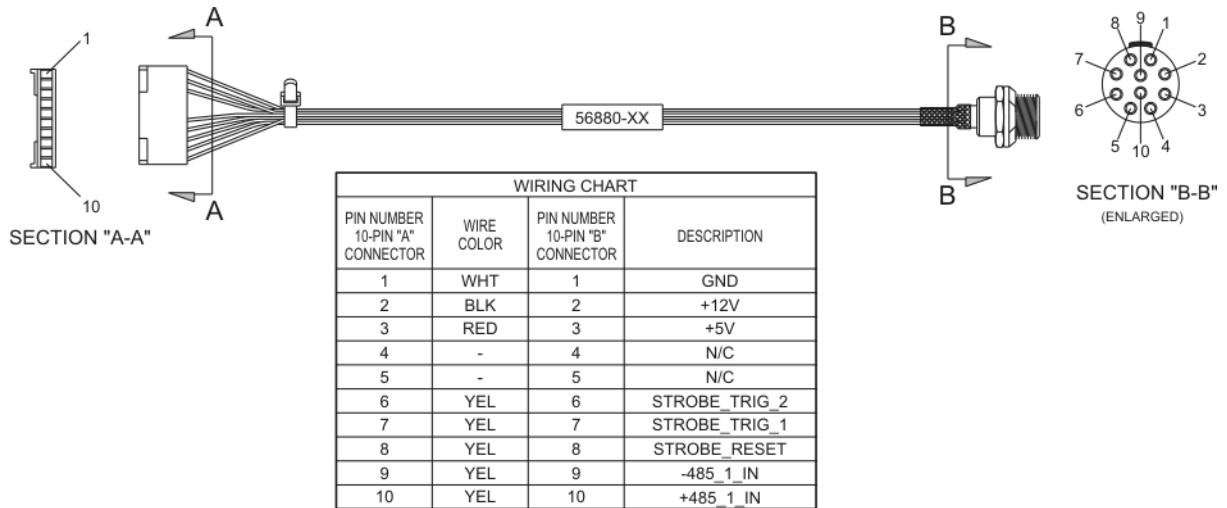

Focus control PET camera module

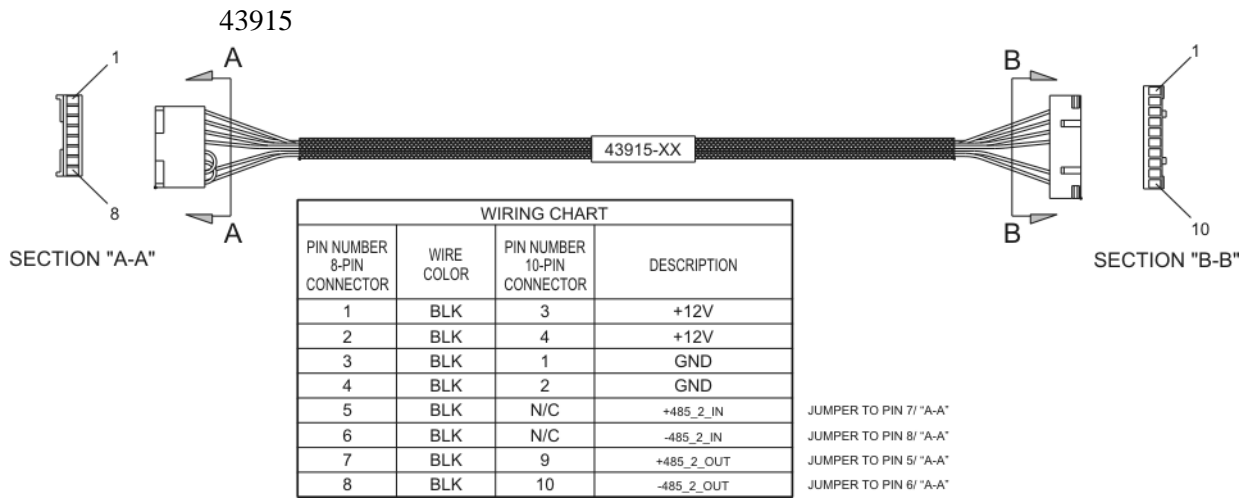

Lighting power

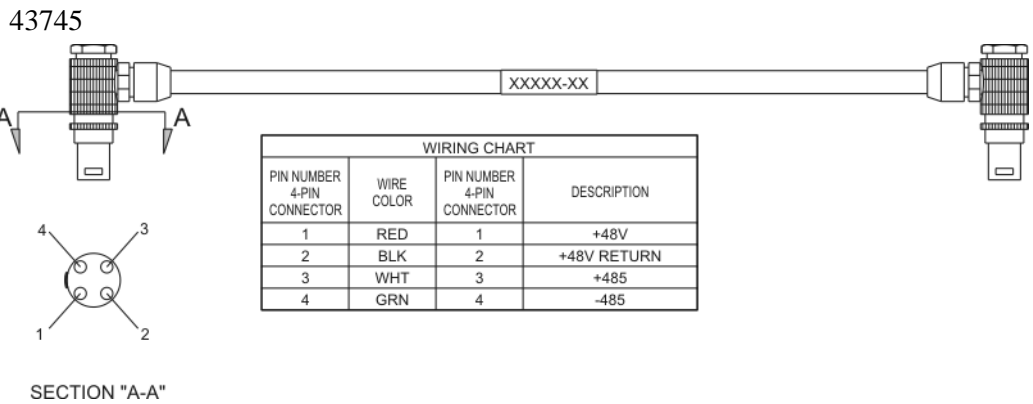

Lighting power

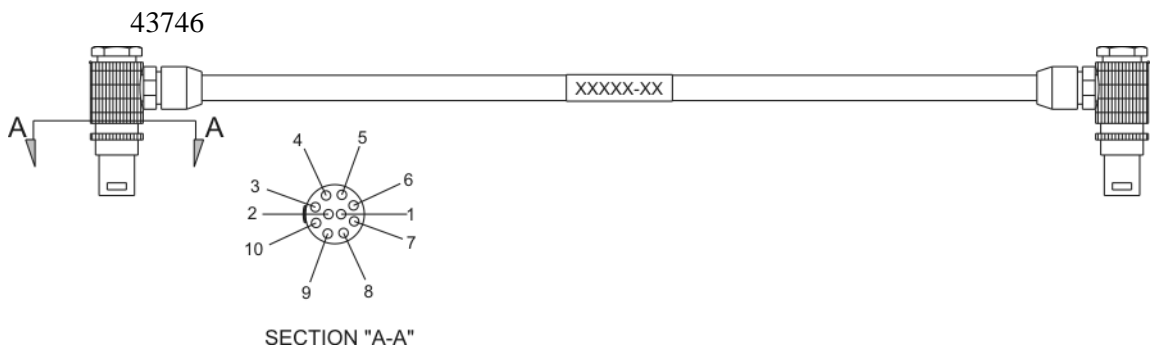

Servo modified with JAE connector PET



485 out PET Seal Surface module

43947

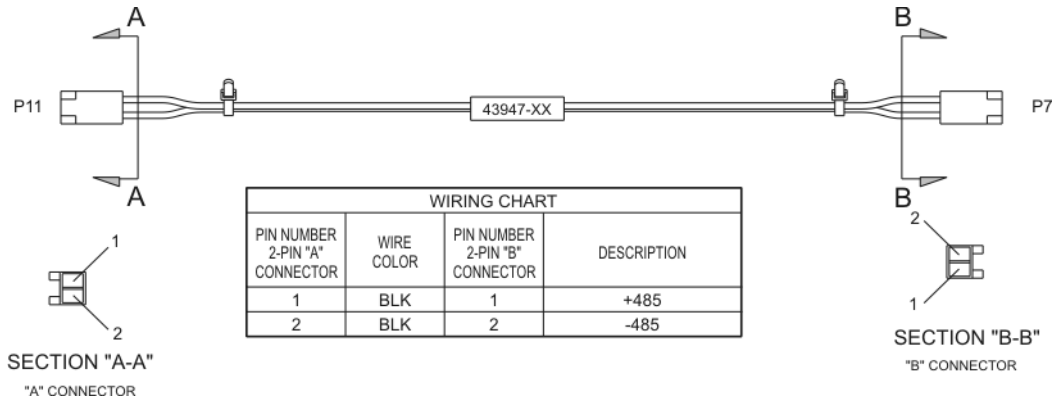

Array power PET Seal Surface module

43945

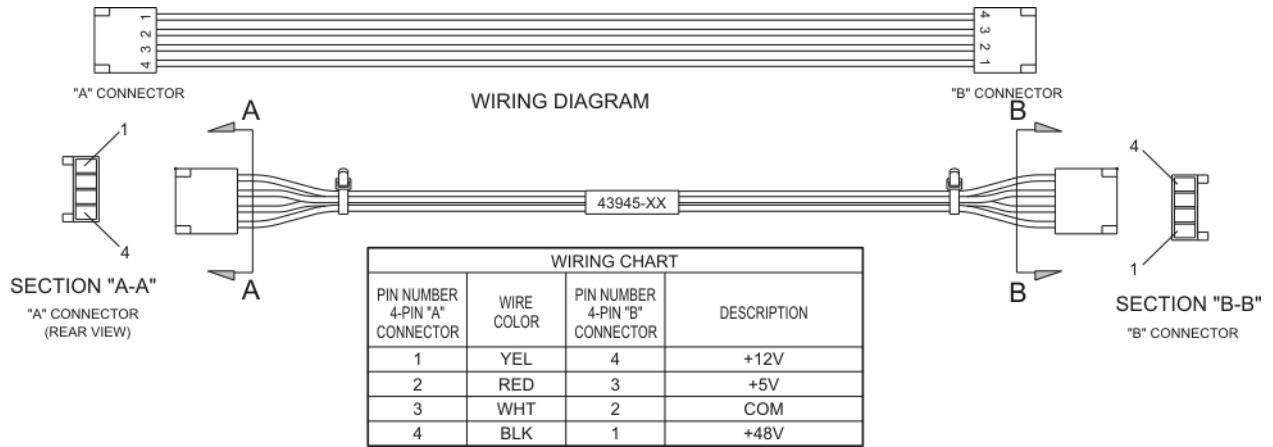

Interconnect 16 zone CP

52090, 56167

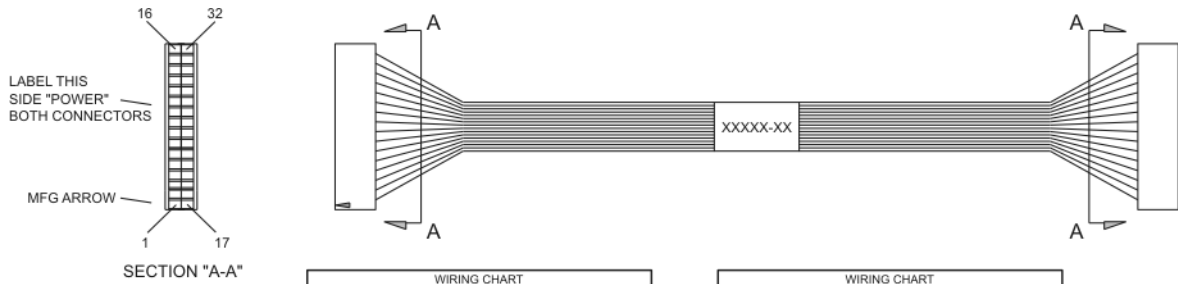

WIRING CHART			
PIN NUMBER 32-PIN CONNECTOR	WIRE COLOR	PIN NUMBER 32-PIN CONNECTOR	DESCRIPTION
1	BLK	1	POWER
2	BLK	2	POWER
3	BLK	3	POWER
4	BLK	4	POWER
5	BLK	5	POWER
6	BLK	6	POWER
7	BLK	7	POWER
8	RED	8	POWER
9	BLK	9	POWER
10	BLK	10	POWER
11	BLK	11	POWER
12	BLK	12	POWER
13	BLK	13	POWER
14	BLK	14	POWER
15	BLK	15	POWER
16	RED	16	POWER

WIRING CHART				
PIN NUMBER 32-PIN CONNECTOR	WIRE COLOR	PIN NUMBER 32-PIN CONNECTOR	DESCRIPTION *	
PAIR 1	17	RED	17	ZONE
PAIR 2	18	WHT	18	ZONE
PAIR 3	19	GRN	19	ZONE
PAIR 4	20	BLU	20	ZONE
PAIR 5	21	YEL	21	ZONE
PAIR 6	22	BRN	22	ZONE
PAIR 7	23	ORG	23	ZONE
PAIR 8	24	WHT	24	ZONE
PAIR 1	25	RED	25	ZONE
PAIR 2	26	WHT	26	ZONE
PAIR 3	27	GRN	27	ZONE
PAIR 4	28	BLU	28	ZONE
PAIR 5	29	YEL	29	ZONE
PAIR 6	30	BRN	30	ZONE
PAIR 7	31	ORG	31	ZONE
PAIR 8	32	WHT	32	ZONE

*CONTROL FOR 16 INDIVIDUAL ZONES.

Chromapulse LED signal trigger

65206

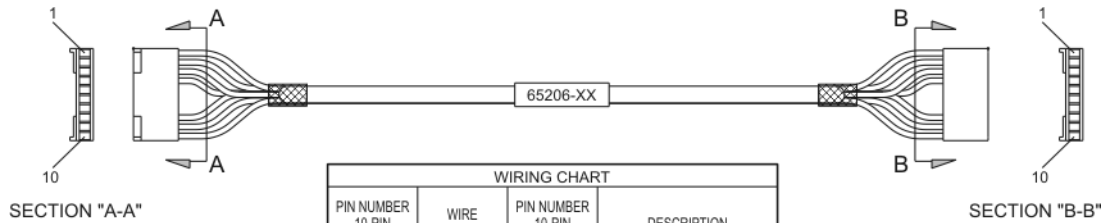

WIRING CHART			
PIN NUMBER 10-PIN CONNECTOR	WIRE COLOR	PIN NUMBER 10-PIN CONNECTOR	DESCRIPTION
1	BLK	1	+485
2	WHT	2	-485
3	BLU	3	RESET
4	-	4	-
5	BRN	5	STROBE_TRIG2 - B
6	-	6	-
7	-	7	-
8	RED	8	+5V
9	ORG	9	+12V
10	GRN	10	GND

Camera control upper

58285

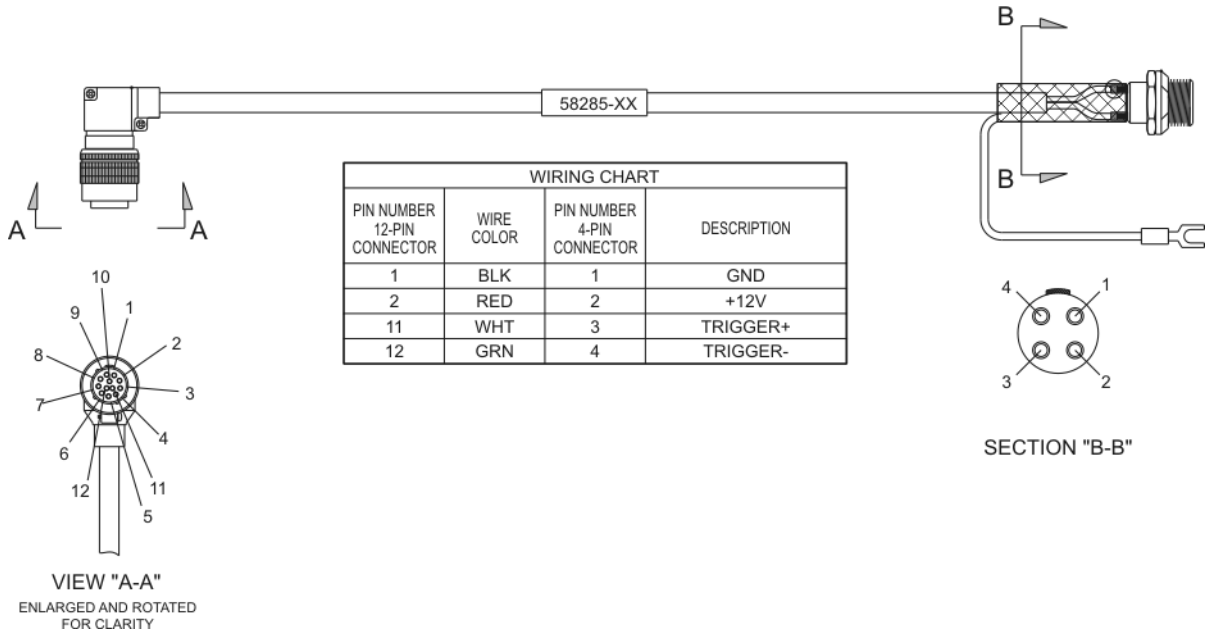

Camera control lower

58586

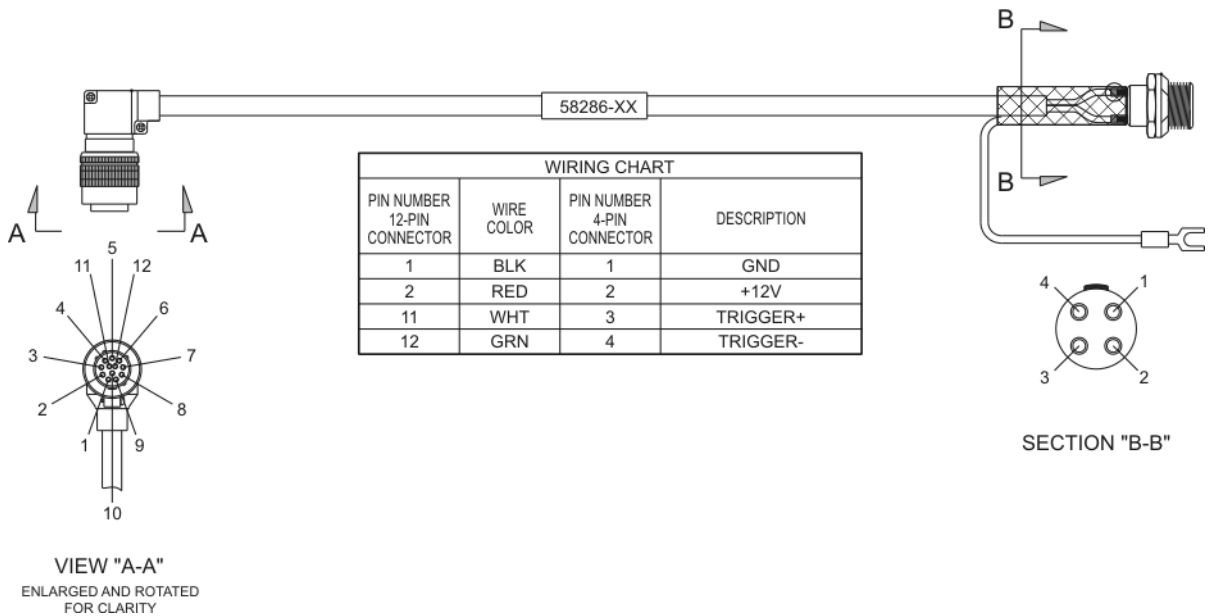

Video CAT6 PPR2 S IV-D

58401

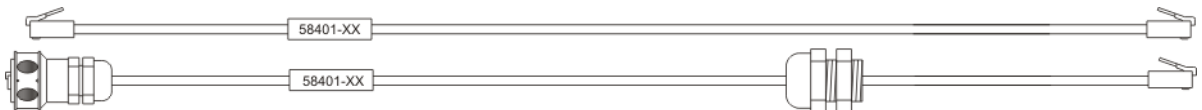

GIG-E camera control PET right-angle

56072

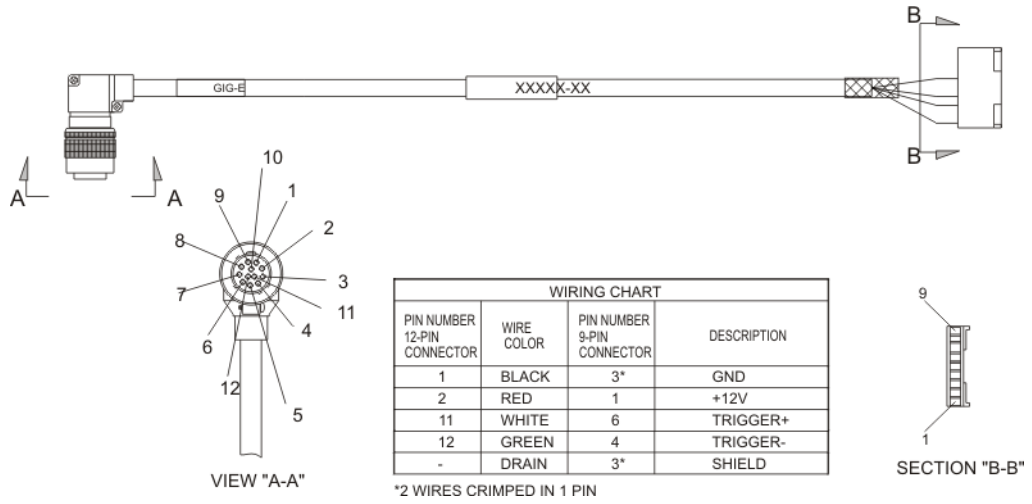

59609 Umbilical 1 camera/ 1 CAT6 Filling S IV-D

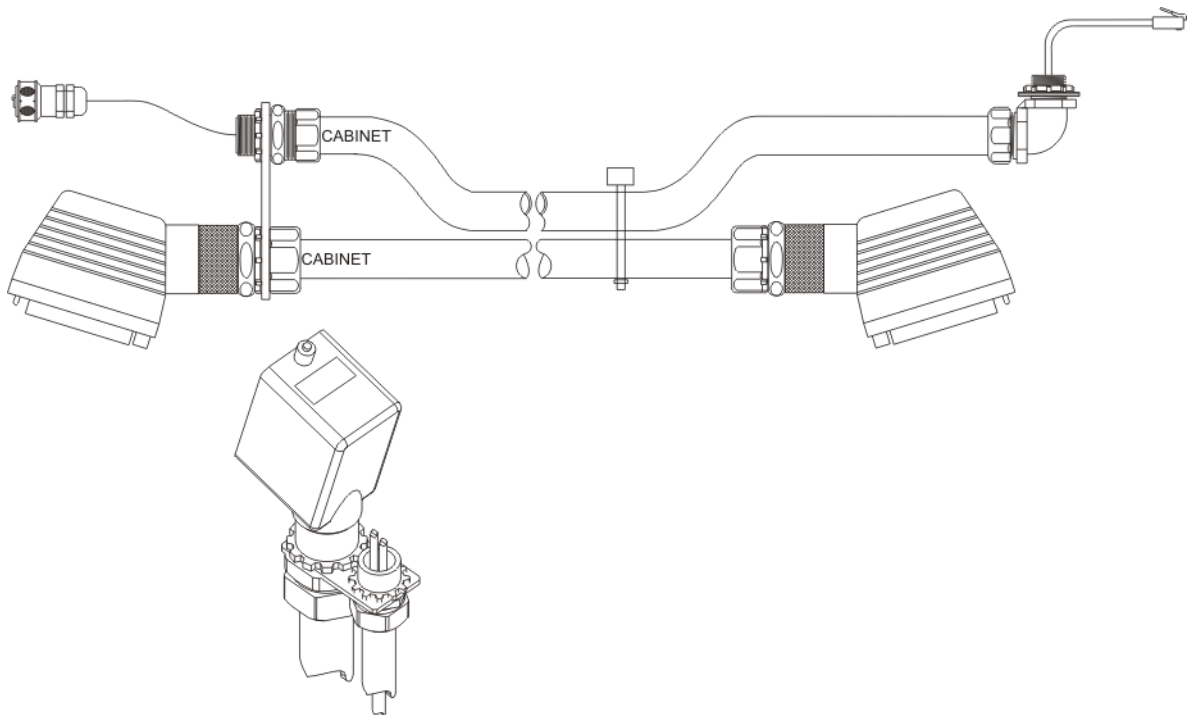

56877 GIG-E camera control int PPR2

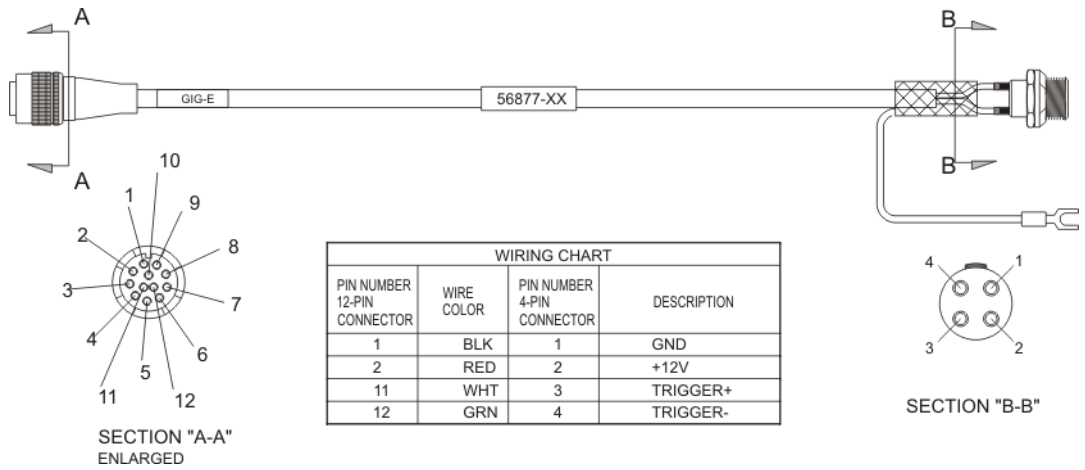

GIG-E camera control PPR2

56879

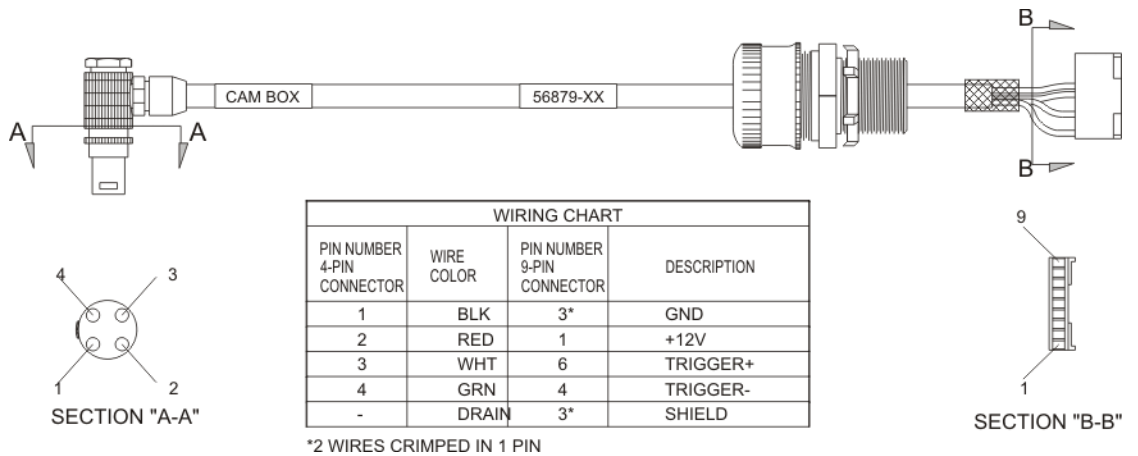

Stepper motor control RS485 comm

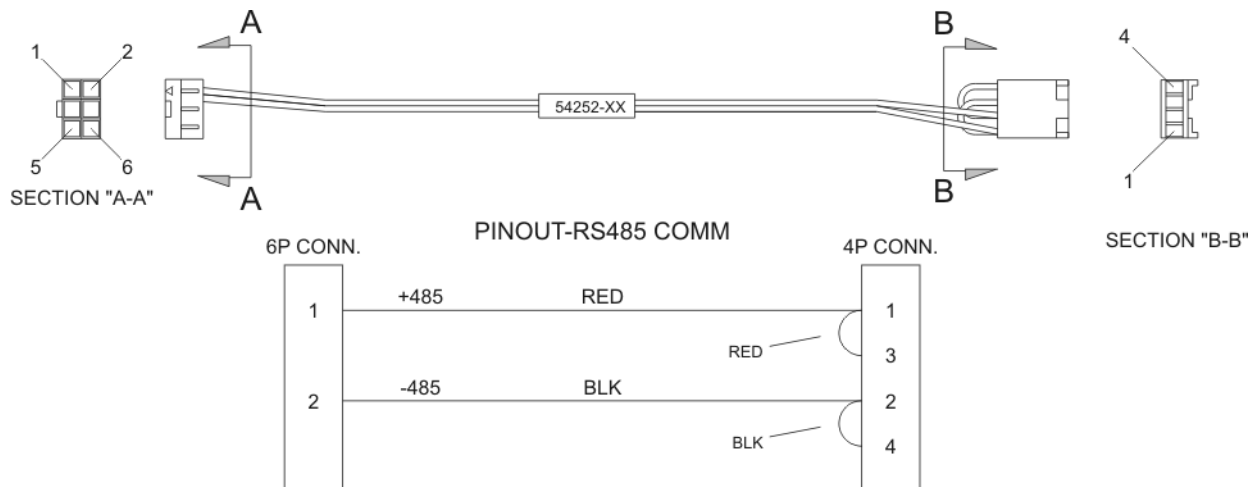

Stepper motor PCB power

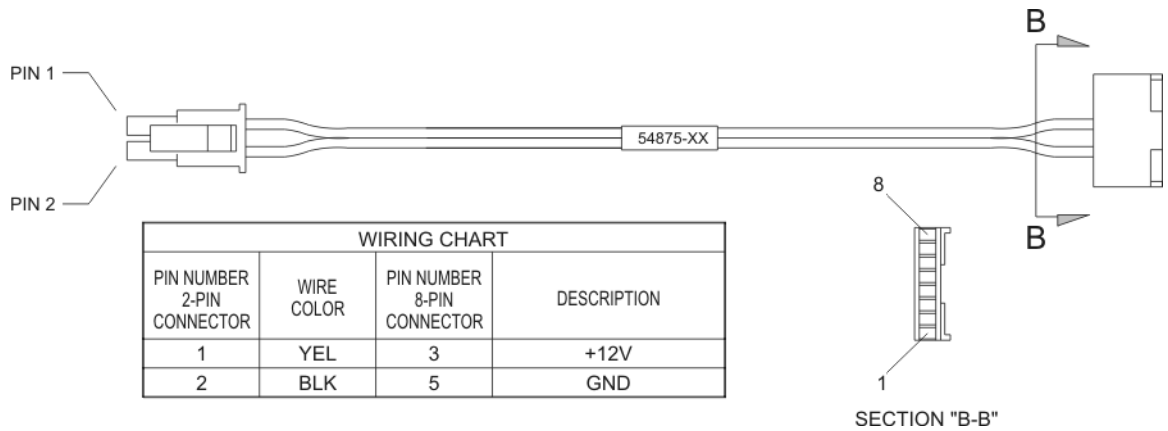

4-pin panel mount 12" leads

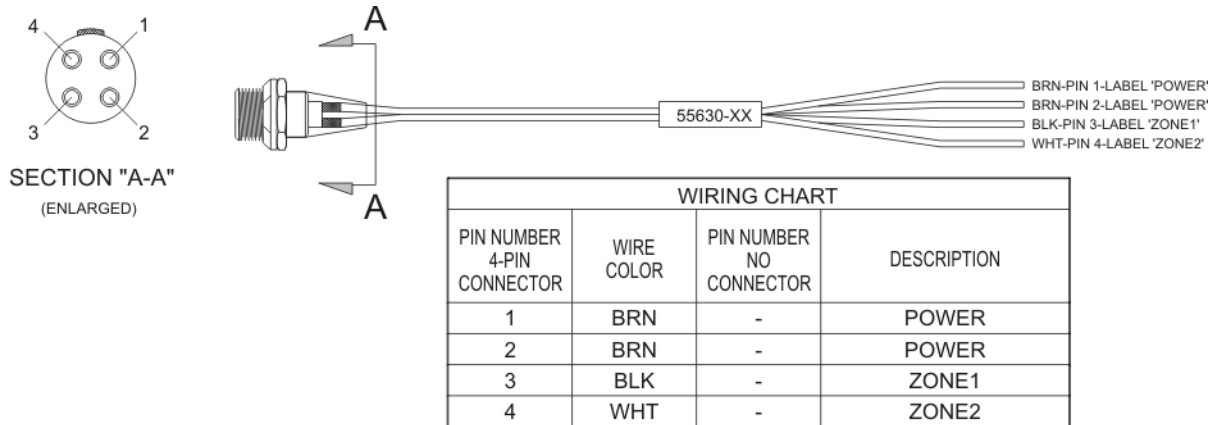

2 limit switches with 6-pin connector

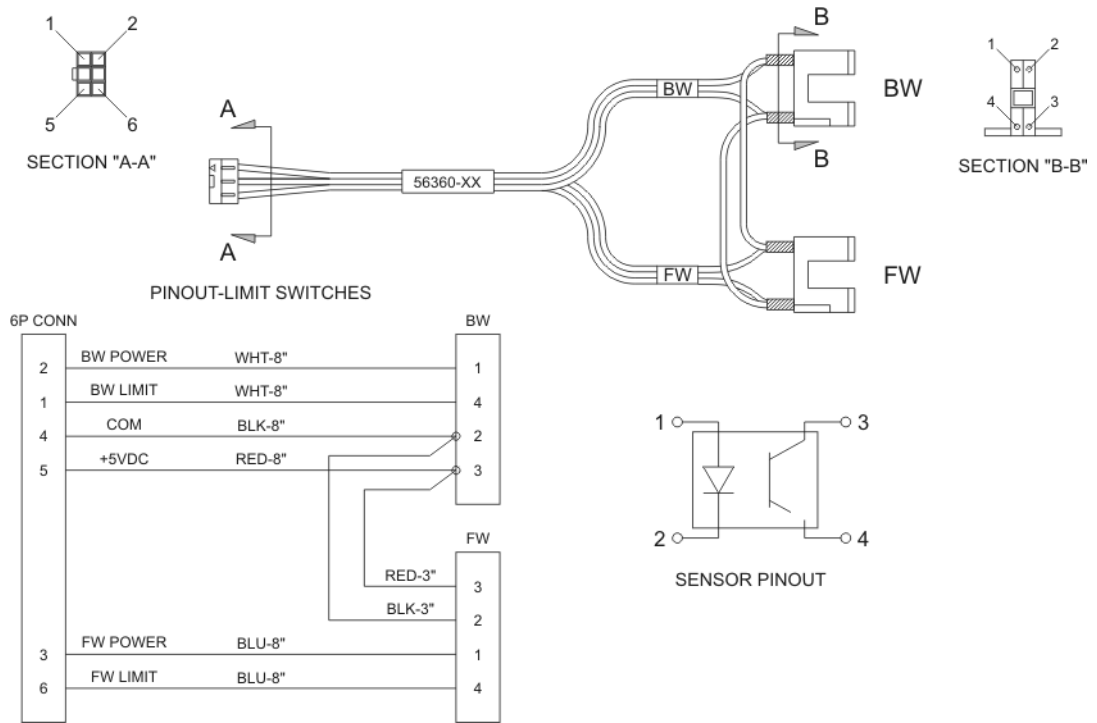

Preform Sidewall inspection module cables

58577 Camera control

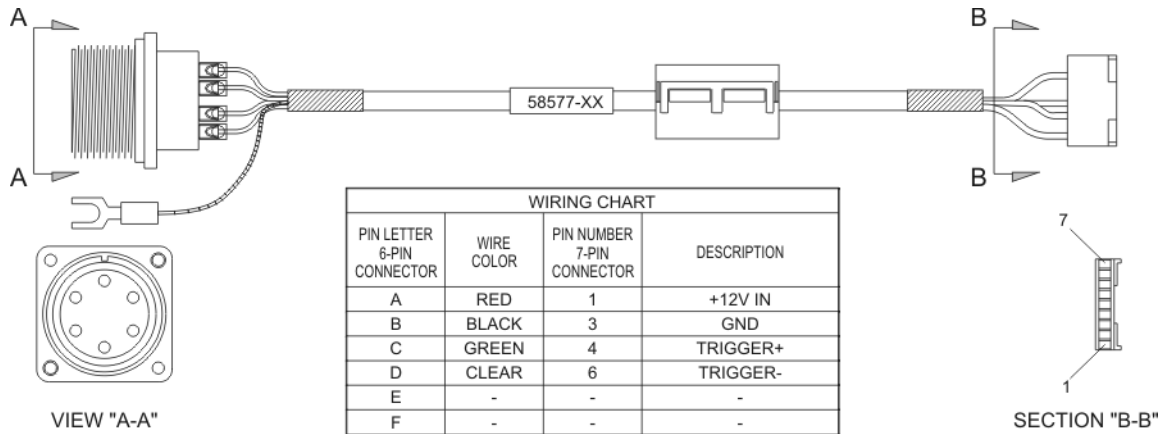

56189 Chromapulse LED power/ RS485

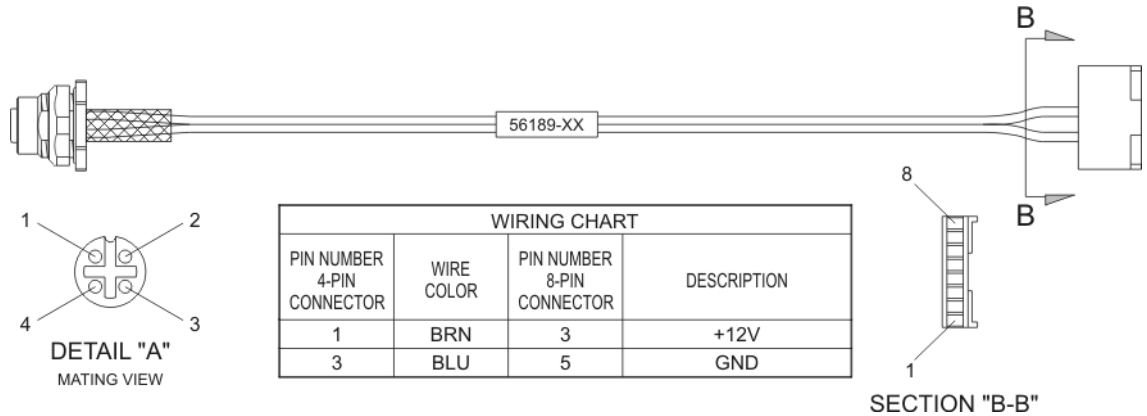

47659 upper array cable

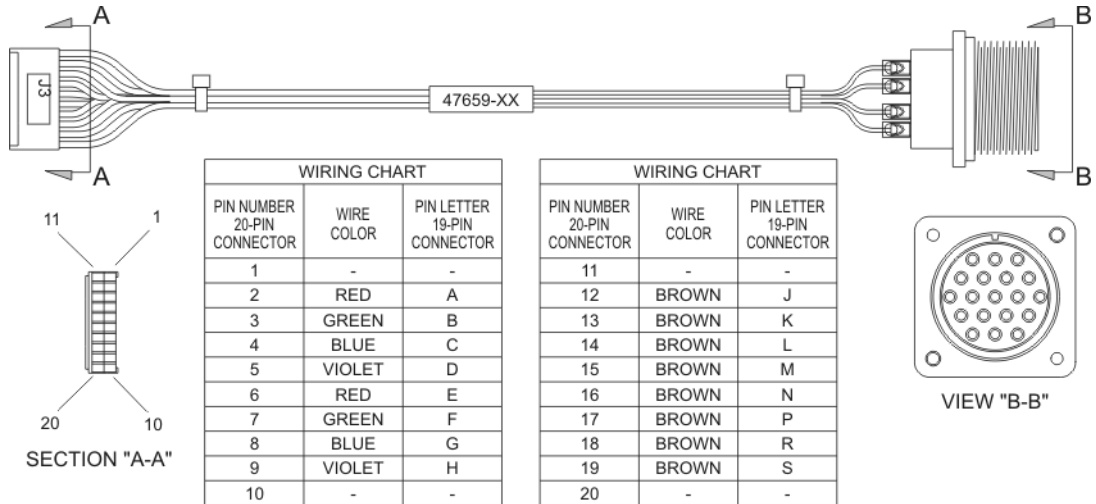

50336 array control 8 zones

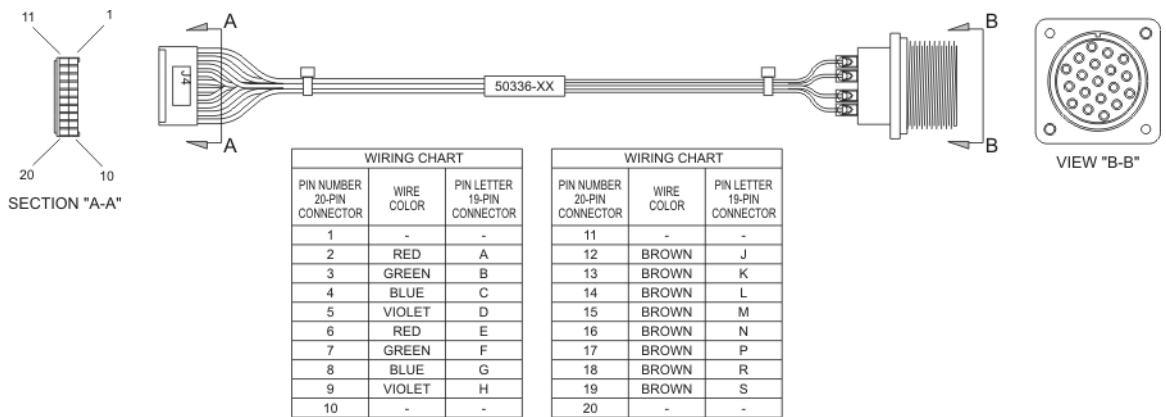

FHCP module cables

Umbilical video 2Cat6 FHCP

58011

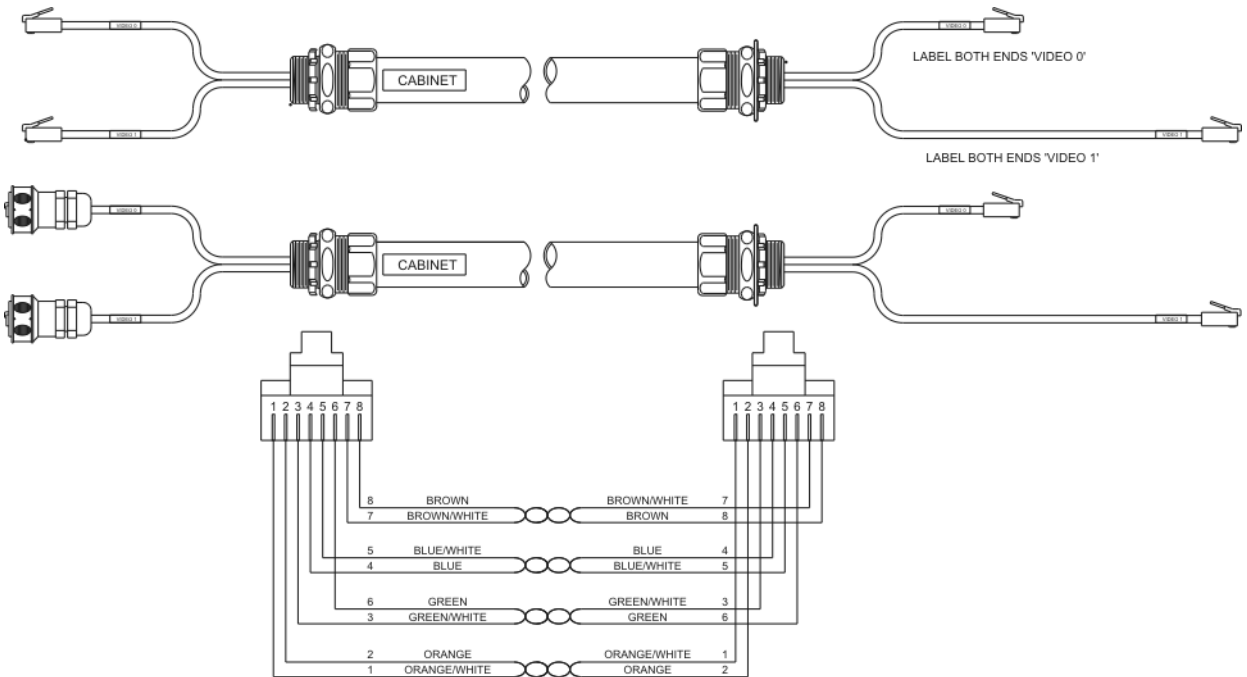

DETAIL "A"

CAT6 CABLE PINOUT PER
TIA/EIA-568-B STANDARD
MATING VIEW

Umbilical video user interface FHCP S IV-D

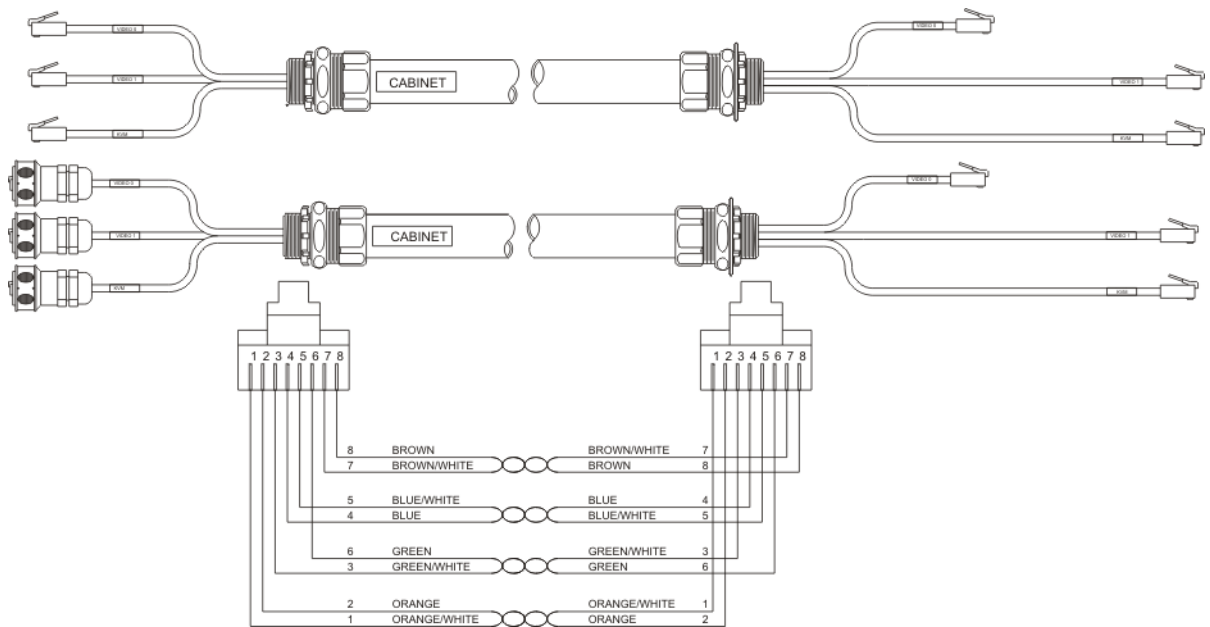

KVM extender Cat6 power cable

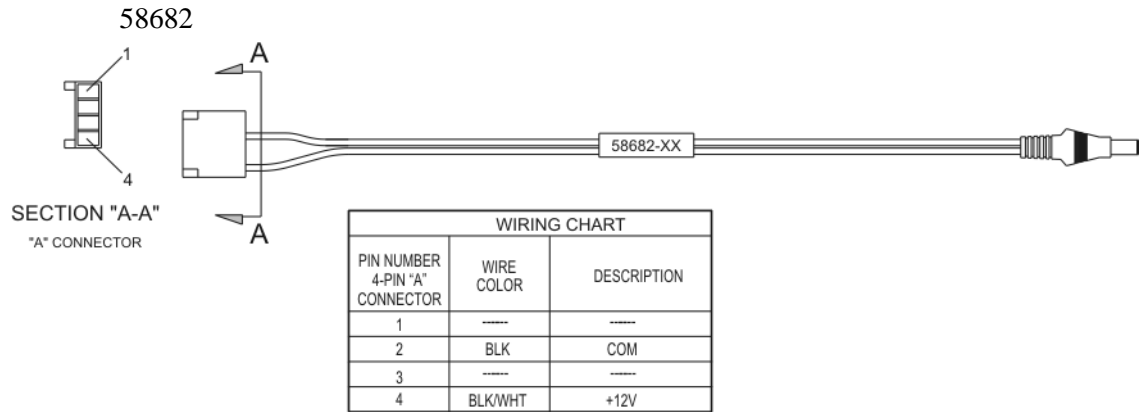

Umbilical camera module 2cam FHCP

57989, 58796, 59036, 59302, 65207, 65210, 65557, 655560, 65563

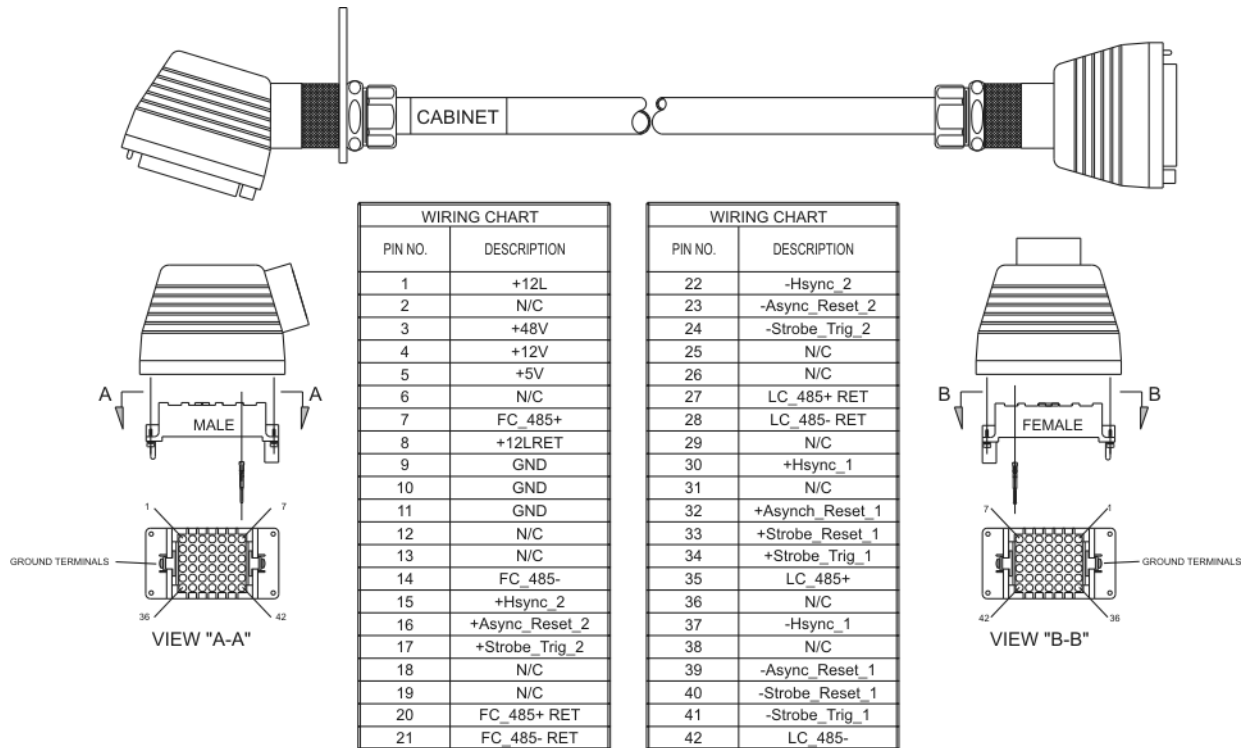

Umbilical camera/ video 2cam FHCP digital

58012

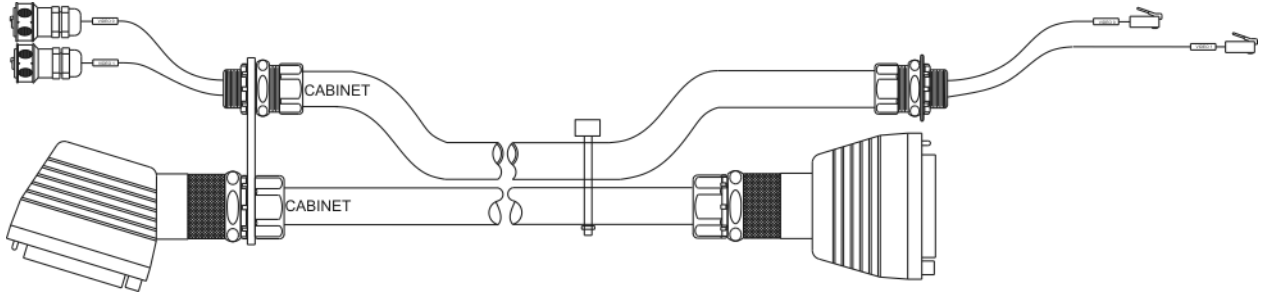

Umbilical 2cam/ 2video/ UI FHCP digital

58794, 58882, 59038, 59300, 65209, 65212, 65556, 65559, 65562

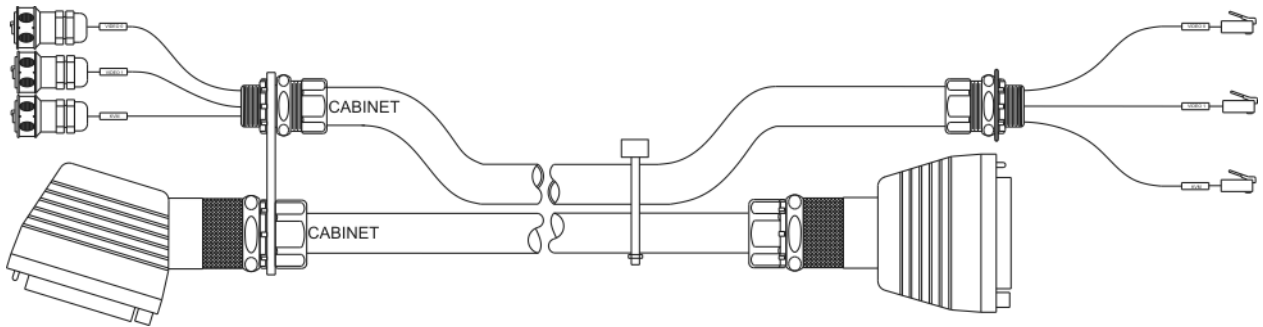

Flat panel FHCP 8 zone

56782, 56840

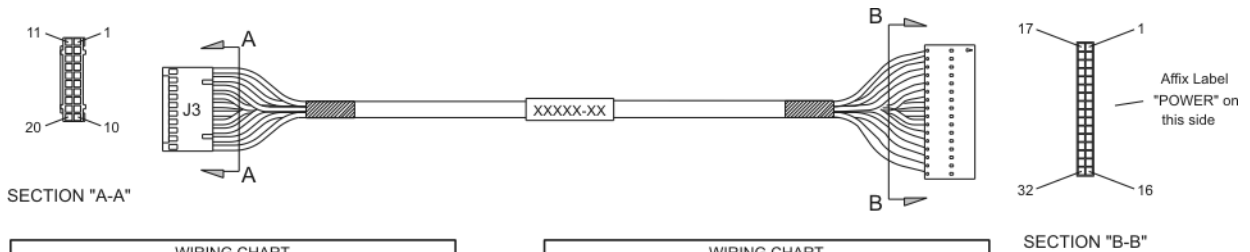

WIRING CHART			
PIN NUMBER 20-PIN CONNECTOR	WIRE COLOR	PIN NUMBER 32-PIN CONNECTOR	DESCRIPTION
2	RED	32	ZONE_1
3	WHT	30	ZONE_2
4	GRN	28	ZONE_3
5	BLU	26	ZONE_4
6	YEL	24	ZONE_5
7	BRN	22	ZONE_6
8	ORG	20	ZONE_7
9	WHT	18	ZONE_8
11	BLACK	-	SHIELD

WIRING CHART			
PIN NUMBER 20-PIN CONNECTOR	WIRE COLOR	PIN NUMBER 32-PIN CONNECTOR	DESCRIPTION
12	BLK	16	POWER
13	BLK	14	POWER
14	BLK	12	POWER
15	BLK	10	POWER
16	BLK	8	POWER
17	BLK	6	POWER
18	BLK	4	POWER
19	RED	2	POWER

HOW TO CONTACT PRESSCO

24/ 7 Customer Support:

440-498-2000

E-mail:

service@pressco.com (mailto:service@pressco.com) or *techsupport@pressco.com*
(mailto:techsupport@pressco.com)

Customer Service Fax:

440-498-4761

Mailing Address:

Pressco Technology Inc. 29200 Aurora Rd. Cleveland, OH USA 44139-1847

Main Phone:

440-498-2600

Web Site:

www.pressco.com (<http://www.pressco.com>)

Business Hours:

Monday - Friday, 8:00am - 5:00pm Eastern Standard Time

INDEX

2

- 2 CAMERA MODULE UMBILICAL • 253
- 2 LIMIT SWITCHES WITH 6-PIN CONNECTOR • 269

4

- 44403, 44461, 59413 CHROMAPULSE LED POWER • 187
- 44404, 44462, 59414 CHROMAPULSE LED SIGNAL • 189
- 44405, 44463, 59415 RS485 SIGNAL RETURN • 189
- 44599, 44407 CHROMAPULSE CAMERA CONTROL • 188
- 45861 POWER MAIN I/O 5/12/12L/48V • 181
- 45862 POWER MAIN I/O 12/24V ISOLATED • 181
- 45899 POWER STATUS • 180
- 45905 CABLE 4 PORT DISTRIBUTION BOX INTERNAL • 182
- 45906 CABLE 8 PORT DISTRIBUTION BOX INTERNAL • 183
- 45914 UPS SHUTDOWN CONTROL • 180
- 45999 8 PORT I/O BOX • 184
- 46000 4 PORT I/O BOX • 184
- 46232 THERMOSTAT • 182
- 46237 SERIAL CONNECTOR DB37M - DB37F • 181
- 47655 CAMERA CONTROL • 191
- 47659 UPPER ARRAY CABLE • 270
- 47915, 47916 CHROMAPULSE LED SIGNAL TRIGGER 2 • 192
- 47993, 47994 CHROMAPULSE LED SIGNAL TRIGGER • 192
- 48167 CABLE LIGHT TREE JUNCTION BOX • 186
- 48190 CABLE LIGHT TREE • 186
- 485 OUT PET SEAL SURFACE MODULE • 263
- 48825 CHROMAPULSE IC1 RING ARRAYS • 194

- 48873 CHROMAPULSE IC1 CAMERA CONTROL • 214
- 48878 CHROMAPULSE POWER VIDEO MUX • 214, 221
- 48880, 50423 CHROMAPULSE RS485 COMM. VIDEO MUX. • 195, 220
- 49397, 49391 CP750E UMBILICAL PANEL/ DOME/ RING • 190
- 49444 DOME ARRAY PIGTAIL • 187
- 49477, 49520, 47654 CAMERA CONTROL • 191
- 4-PIN PANEL MOUNT 12 • 268
- 4-PORT SERIAL BOARD • 20
- 4-PORT SERIAL BOARD JUMPER SETTINGS • 74

5

- 50322 ARRAY CONTROL 16 ZONES • 258
- 50336 ARRAY CONTROL 8 ZONES • 270
- 50428 BLOB UMBILICAL #1 • 196
- 50429 BLOB UMBILICAL #2 • 196
- 50430 BODY CAMERA MODULE • 198
- 50431 CAMERA CONTROL NECK/ FLANGE EXT. 1 • 202
- 50432 CAMERA CONTROL NECK/ FLANGE EXT. 2 • 202
- 50434 ENCODER/ PART DETECT/ REJECT • 205
- 50435 ENCODER/ PART DETECT/ REJECT INSIDE BLOB • 204
- 50436, 53659, 53812 ENCODER TO PDX • 204
- 50437 ENCODER EXTERNAL • 205
- 50438, 51450 ENCODER BEI H25 • 206
- 50439, 50627, 53667 REJECT SOLENOID • 205
- 50505 PDX EXPANSION • 207
- 50528 ARRAY/ CAMERA CONTROL • 200
- 50539, 53813 CHROMAPULSE LED SIGNAL • 208
- 50540 RS485 SIGNAL RETURN • 208
- 50541 POWER CABLE VIDEO MUX • 209
- 50542, 53663 CAMERA CONTROL VIDEO MUX • 209

50543 RS485 COMMUNICATION VIDEO MUX • 210
 50626, 51451 REJECT EXTERNAL • 206
 50674, 51453 ARRAY CONTROL NECK/ FLANGE EXT. 1 • 202
 50675 ARRAY CONTROL NECK/ FLANGE EXT. 2 • 203
 50676 ARRAY/ CAMERA CONTROL BASE EXT. 2 • 201
 50726 CHROMAPULSE PANEL ARRAY PIGTAIL • 188
 50866 ENCODER REJECT/ CONFIRM • 207
 51049 CHROMAPULSE CAMERA CONTROL • 237
 51215, 57484 CHROMAPULSE CAMERA CONTROL • 216
 51217 CHROMAPULSE LED POWER • 217
 51218, 51048 CHROMAPULSE ARRAY • 218, 236
 51254 CHROMAPULSE POWER VIDEO MUX • 221
 51255 CHROMAPULSE CAMERA CONTROL VIDEO MUX • 222
 51452 REJECT SOLENOID • 213
 51454 ARRAY CONTROL NECK/FLANGE EXT. 2 • 213
 51479 BLOB UMBILICAL #1 • 197
 51509 BLOB UMBILICAL #2 • 197
 52016 CHROMAPULSE BODY ARRAY • 220
 52019, 52017, 51645, 52024 CHROMAPULSE CAMERA CONTROL 90 DEGREES • 219, 222, 235
 52020, 52878 CHROMAPULSE NECK/ FLANGE ARRAY • 223
 52189 CAMERA MODULE UMBILICAL • 252
 52883 CHROMAPULSE DOME/ FLANGE ARRAY • 223
 52886 OVERTEMP SENSOR AIR CONDITIONER • 182
 53147 BODY ARRAY CONTROL • 199
 53148 BODY ARRAY CONTROL • 211
 53149 BODY ARRAY EXT. 2 • 212
 53150 CABLE BODY ARRAY CP4410 • 211
 53666 ENCODER/ PDX/ REJECT SMALL ENCLOSURE • 210
 53811 NECK/FLANGE ARRAY CONTROL • 203
 53814 REJECT • 203
 54132 CP/E 9 ZONE MAIN, 4 ZONE FILL, 3 ZONE RING • 254
 54133 CP/E 9 ZONE MAIN, 4 ZONE FILL, 3 ZONE RING • 255
 54230 RINGLIGHT 2 ZONES • 259
 54305 DB37M - DB9M • 259
 54525 LANE SENSORS REJECT OUT ULTRA I/O • 257
 54549 CP/E DUAL 3 ZONE LOWER ARRAY • 256
 54790 CAMERA CONTROL NECK MODULE • 257
 55314 CP/E 3 ZONE AUX • 258
 56187 GIG-E CAMERA CONTROL CP500/750 • 193
 56189 CHROMAPULSE LED POWER/ RS485 • 270
 56841 ARRAY CP4412E • 237
 56842 FOUR CAMERA UMBILICAL INSIDE CABINET • 224
 56877 GIG-E CAMERA CONTROL INT PPR2 • 267
 58010 CABLE VIDEO CAT6 S IV-D • 245
 58184 DIGITAL CAMERA CONTROL GLAND PLATE TO CAMERA • 212
 58186 DIGITAL CAMERA CONTROL BLOB TO GLAND PLATE • 212
 58188 VIDEO CAT6 BELVAC BLOB THROUGH GLAND PLATE • 213
 58189 DIGITAL CAMERA CONTROL BLOB • 199
 58190 DIGITAL CAMERA CONTROL CP4402/ CP4410 CAMERA BOX • 213
 58371 GIG-E CAMERA CONTROL CP 8FT. CORD GRIP • 251
 58577 CAMERA CONTROL • 269
 59118 GIG-E CAMERA CONTROL CP500/750R • 193
 59411 ARRAY CABLE (SHORT) • 238

59412 ARRAY CABLE (LONG) • 239
59608 UMBILICAL VIDEO CAT6 FILLING S
IV-D • 245
59609 UMBILICAL 1 CAMERA/ 1 CAT6
FILLING S IV-D • 266

A

AC POWER SWITCH AND FAN WIRING
SERIES IV • 70
AC/DC POWER DRAWER • 14
AC/DC POWER DRAWER TERMINAL
BLOCK • 69
AC/DC POWER DRAWER WIRING DETAILS
• 68
ACCENTUATING AND HIDING PART
FEATURES • 113
ADDITIONAL CHECKS • 109
ADDITIONAL TROUBLESHOOTING HINTS
• 108
ADJUST LIGHTING THROUGH SOFTWARE
• 124, 139, 143, 155, 164, 176
ADJUST MODULE HEIGHT • 172
ADJUSTING THE CP/E SERIES MODULE •
172
ADJUSTING THE CP4402 INSPECTION
MODULE • 136
ADJUSTING THE CP4402E AND CP4410E
INSPECTION MODULES • 152
ADJUSTING THE CP4410 MODULE • 140
ADJUSTING THE CP4411E/ CP4412E
INSPECTION MODULE • 161
ADJUSTING THE CP500 OR CP750
INSPECTION MODULE • 120
AIR CONDITIONER FILTER • 99
AIR CONDITIONING UNIT MULTI-VOLT
WIRING S IV-D • 71
AIR FILTER MAINTENANCE • 98
APERTURE ADJUSTMENT • 124, 139, 143,
154, 164, 176
ARRAY POWER PET SEAL SURFACE
MODULE • 263
ARRAY POWER/ 485 OUT PET • 260
ARRAY POWER/ 485 OUT PPR2 • 260
ARRAY/ CAMERA CONTROL
INTERCONNECT • 130

B

BASE AND NECK CAMERA SIGNAL
DISTRIBUTION BOARD JUMPER
SETTINGS • 78
BASE AND NECK LIGHTING BOARD
SWITCH SETTINGS • 75
BELVAC GLAND PLATE TO CAMERA
MODULE INTERCONNECT • 135
BELVAC INSPECTION MODULES • 194
BELVAC INTERCONNECTION DIAGRAMS
• 129

C

CABINET
CABINET FILTERS • 98
CABINET CABLES • 180
CABINET COMPONENTS S IV-D • 61
CABINET TO ELECTRONIC ENCLOSURE
INTERCONNECT • 133
CABLE CAMERA MODULE 2CAM S4 53610
• 250
CABLE GIG-E CAMERA CONTROL CP500
CTRL BOX 56186 • 193
CABLE WIRING DIAGRAMS • 179
CABLE WIRING DIAGRAMS CP/E
MODULES • 252
CAMERA ADJUSTMENTS • 124, 138, 143,
154, 163
CAMERA AND LIGHTING SIGNALS • 52
CAMERA AND LIGHTING SIGNALS • 52
CAMERA CONTROL LOWER • 265
CAMERA CONTROL UPPER • 265
CAMERA DRIVER BOARD JUMPER
SETTINGS • 80
CAMERA DRIVER BOARD JUMPER
SETTINGS • 80
CAMERA HEIGHT ADJUSTMENT • 124, 143
CAMERA MODULE JUMPER/SWITCH
SETTINGS • 74
CAMERA POSITION ADJUSTMENT • 138,
154, 163, 174
CAMERA SIGNAL DISTRIBUTION BOARD
S IV-D+ • 75
CAMERA SIGNALS TEST POINTS • 55

CAMERA SWITCHER • 16
 CAMERA SWITCHER S IV-D+ • 16
 CHANGING CAMERAS IN SERIES IV-D, IV-D+ SYSTEMS • 105
 CHROMAPULSE BEAM SPLITTER • 90
 CHROMAPULSE CABLES • 187
 CHROMAPULSE CABLES - MULTIPLE MODULE TYPES • 240
 CHROMAPULSE LED POWER • 194, 217
 CHROMAPULSE LED SIGNAL • 219
 CHROMAPULSE LED SIGNAL TRIGGER • 264
 CHROMAPULSE LIGHTING BOARD SWITCH SETTINGS • 83
 CHROMAPULSE LIGHTING BOARD SWITCH SETTINGS • 83
 CHROMAPULSE RS485 SIGNAL RETURN • 195, 218, 238
 CHROMAPULSE SIGNAL DISTRIBUTION BOARD 1 JUMPER SETTINGS • 81
 CHROMAPULSE SIGNAL DISTRIBUTION BOARD 2 JUMPER SETTINGS • 82
 CHROMAPULSE SIGNAL DISTRIBUTION BOARD 2 JUMPER SETTINGS • 82
 CHROMAPULSE UMBILICAL CAMERA MODULE • 240
 CHROMAPULSE™ INSPECTION THEORY • 111
 CIRCUIT BOARD PROTECTION • 73
 CLEANING GLASS SURFACES • 88
 CLEANING OPTICAL SURFACES • 88
 CLEANING PLASTIC SURFACES • 92
 CLEANING THE AIR CONDITIONER FILTER • 99
 CLEANING THE BEAM SPLITTER • 89
 CLEANING THE CAMERA LENS • 89
 CLEANING THE ELLIPSOIDAL MIRROR • 94
 CLEANING THE PART DETECTOR • 95
 CLEANING THE PC AIR FILTER • 98
 CLEANING THE PROCESSOR CABINET AIR FILTERS • 98
 CLEANING THE SECONDARY LENS • 91
 COMMUNICATION PORT TEST POINTS • 55

COMPUTER • 13
 COMPUTER CONNECTIONS S IV-D • 65
 CONNECTIONS ON SIDE OF PROCESSOR CABINET • 12
 CORRELATION RESET AND CPX LEARN • 30
 CP/E SERIES MODELS • 90
 CP/E SERIES MODULES • 167
 CP1200E/ CP1500E • 168
 CP1500 DOME LIGHT DIFFUSER • 93
 CP1500 MODULE • 187
 CP1500 MODULES • 91
 CP4402 COMPONENTS • 137
 CP4402, CP4410 BELVAC MODULES • 127
 CP4402E INSPECTION MODULE • 220
 CP4402E, CP4410E MODULES • 147
 CP4402E/ CP4410E COMPONENTS • 148
 CP4410 COMPONENTS • 142
 CP4410 INSPECTION MODULE • 215
 CP4410E INSPECTION MODULE • 216
 CP4411E, CP4412E COMPONENTS • 162
 CP4411E, CP4412E INSPECTION MODULES • 224
 CP4411E, CP4412E MODULES • 157
 CP4411E/ CP4412E INTERCONNECT DIAGRAMS • 160
 CP4422E INSPECTION MODULE • 238
 CP500, CP750 MODULES • 117
 CP500/ 750 DOME LIGHT DIFFUSER • 94
 CP500/ 750 MODULES • 92
 CP500/ CP750 MODULES • 191
 CP500E/ CP750E • 167
 CP750E MODULE (OLD STYLE) • 190
 CPIC1 INSPECTION MODULE • 214

D

DESCRIPTION • 117, 127, 147, 157
 DESCRIPTION OF CP/E MODULES • 167
 DUAL USER INTERFACE • 10
 DUAL USER INTERFACE (OPTIONAL) • 10

E

ELECTRONIC ENCLOSURE TO BELVAC
GLAND PLATE INTERCONNECT • 134
ELLIPSOIDAL MIRROR CLEANING • 94
ENCODER, PART DETECT, REJECT
INTERCONNECT • 132
EXTENDED I/O • 30
EXTENDED I/O DAUGHTER BOARD
PINOUTS • 59

F

FG TRIGGER JUMPER S IV-D • 66
FHCP MODULE CABLES • 271
FLAT PANEL FHCP 8 ZONE • 273
FOCUS ADJUSTMENTS • 124, 138, 143, 154,
163, 174
FOCUS CONTROL PET CAMERA MODULE
• 262

G

GIG-E CAMERA CONTROL • 216
GIG-E CAMERA CONTROL CP • 235
GIG-E CAMERA CONTROL CP RIGHT-
ANGLE • 249
GIG-E CAMERA CONTROL PET RIGHT-
ANGLE • 266
GIG-E CAMERA CONTROL PPR2 • 267
GLAND PLATE • 12
GLAND PLATE CONNECTIONS S IV-D • 64
GLAND PLATE S IV-D+ • 13
GLASS CLEANING • 88

H

HARDWARE AND SOFTWARE FUNCTIONS
• 19
HARDWARE COMPONENT OVERVIEW • 9
HOW TO CONTACT PRESSCO • 274
HOW TO POWER UP THE INTELLISPEC • 17
HOW TO SHUT DOWN THE INTELLISPEC •
16

I

I/O ASSIGNMENTS • 25
I/O SIGNALS - TEST POINT REFERENCE •
33

I/O SIGNALS TEST POINTS • 33
IMAGE PROCESSING • 19
INPUT SIGNALS AND DEVICES • 26
INPUT SIGNALS DESCRIPTION • 26
INSPECTION MODULES • 10
INSTALLING CP4402 INTO BELVAC • 139
INSTALLING CP4410 INTO BELVAC • 144
INTELLISPEC SYSTEM • 9
INTELLISPEC SYSTEM BLOCK DIAGRAM
SERIES IV-D • 22
INTELLISPEC SYSTEM SOFTWARE • 20
INTENSITY AND IMAGE BLUR • 113
INTERCONNECT 16 ZONE CP • 264
INTERCONNECT DIAGRAM CP/E
MODULES SERIES IV • 171
INTRODUCTION • 5
ISOLATED USER INPUTS • 27

J

JUMPER AND SWITCH SETTINGS • 73

K

KVM EXTENDER CAT6 POWER CABLE •
272

L

LED CONTROL PET CAMERA MODULE •
261
LED CONTROL PPR2 • 261
LIGHT TREE • 33
LIGHTING ADJUSTMENTS • 124, 139, 143,
154, 164, 176
LIGHTING POWER • 262
LIGHTING SETUP TIPS • 113
LIGHTING ZONES
CP4402E, CP4410E • 128, 149
CP4411E, CP4412E • 157
LIGHTING ZONES CP/E MODULES • 167
LIGHTING ZONES CP500, CP750 • 117

M

MAIN I/O BOARD • 15
MAIN I/O BOARD LEDs AND TEST POINTS
• 48

MAIN I/O BOARD SERIES IV-D • 43
 MAIN I/O BOARD, FRONT VIEW • 44
 MAIN I/O BOARD, REAR VIEW • 45
 MAIN I/O CONNECTIONS S IV-D • 63
 MAIN I/O DAUGHTER BOARD PINOUTS • 57
 MAIN I/O DAUGHTER BOARD PINOUTS 2 • 58
 MAIN I/O FRONT CONNECTIONS S IV-D • 67
 MAIN I/O IN SERIES IV-D • 43
 MAIN I/O JUMPER SETTINGS • 45
 MAIN I/O SWITCH SETTINGS • 47
 MAINTAINING THE MOUNTING ASSEMBLY • 96
 MAINTENANCE • 139, 144
 MAINTENANCE • 155, 164, 176
 MAINTENANCE FREQUENCY • 87
 MAINTENANCE OF CP500, CP750, CP750E MODULES • 124
 MISCELLANEOUS CHECKS • 109
 MODULE HEIGHT ADJUSTMENT • 122
 MODULES WITH PLASTIC SHIELDS • 95

N

NO IMAGE DISPLAY • 108
 NO IMAGE DISPLAY, ALL CAMERAS • 103
 NO IMAGE DISPLAY, ONE CAMERA • 104
 NO POWER (BLUE LIGHT TREE LAMP OFF) • 102

O

OBSERVE PART IMAGE • 123, 138, 143, 153, 163, 174
 OUTPUT SIGNALS AND DEVICES • 31
 OUTPUT SIGNALS DESCRIPTION • 31
 OVERVIEW AND THEORY • 111

P

PET CAMERA MODULE CABLES • 260
 POWER CONNECTIONS S IV-D • 62
 POWER DOWN INTELLISPEC • 16
 POWER DRAWER • 14
 POWER UP INTELLISPEC • 17

PREFORM SIDEWALL INSPECTION MODULE CABLES • 269
 PRESSCO - HOW TO CONTACT • 274
 PRIO BOARD • 19
 PRIO SIGNALS TEST POINTS • 54
 PROCESSOR CABINET • 9
 PROCESSOR CABINET AIR FILTER MAINTENANCE • 98
 PROCESSOR CABINET COMPONENTS • 12
 PROCESSOR CABINET JUMPER/SWITCH SETTINGS • 74

R

REJECT SETTINGS • 145
 REMOVING CP4402 FROM BELVAC • 136
 REMOVING CP4410 FROM BELVAC • 141
 REPLACING CAMERA • 176
 REPLACING FILTER/ REGULATOR FILTERS • 97
 RING LIGHT DIFFUSER • 94

S

SEAL SURFACE LIGHTING BOARD SWITCH SETTINGS • 76
 SECONDARY LENS CLEANING • 91
 SEQUENCE OF INSPECTION EVENTS • 23
 SERVO MODIFIED WITH JAE CONNECTOR PET • 262
 SIGNALS AVAILABLE FOR CHECKING • 53
 STATIC DISCHARGE PROTECTION • 74
 STATIC DISCHARGE PROTECTION • 7
 STEPPER MOTOR CONTROL RS485 COMM • 267
 STEPPER MOTOR PCB POWER • 268
 SWITCH SIDES • 174
 SWITCHES MAIN I/O • 47
 SYSTEM LEVEL INTERCONNECT CP4402E/ CP4410E • 151
 SYSTEM LEVEL INTERCONNECT CP4411E/ CP4412E SERIES IV • 160
 SYSTEM LEVEL INTERCONNECT CP750 SERIES IV • 119
 SYSTEM NOT REJECTING ANY PARTS • 105

SYSTEM NOT REJECTING ANY PARTS • 108
SYSTEM REJECTING ALL PARTS • 109
SYSTEM REJECTING GOOD PARTS • 108

T

TERMINAL BLOCK TB1 • 27
TROUBLESHOOTING • 101
TROUBLESHOOTING FLOWCHARTS • 101
TURN OFF SYSTEM POWER • 73
TYPOGRAPHICAL CONVENTIONS • 6

U

ULTRA I/O OPTION • 37
ULTRA I/O WIRING 1 OF 3 • 40
ULTRA I/O WIRING 2 OF 3 • 41
ULTRA I/O WIRING 3 OF 3 • 42
UMBILICAL 1 CAMERA/ 1 CAT6 S IV-D • 246
UMBILICAL 1 CAMERA/ 1 CAT6 S IV-D BRAIDED • 246
UMBILICAL 1 CAMERA/ 1 VIDEO S IV-D • 246
UMBILICAL 1 CAMERA/ 2 CAT6 S IV-D+ • 248
UMBILICAL 2 CAMERA DUAL TAP 16 ZONE CP4411 • 232
UMBILICAL 2 CAMERA/ 2 CAT6 S IV-D • 247
UMBILICAL 2 CAMERA/ 2 VIDEO S IV-D • 247
UMBILICAL 2 CAMERA/ 4 VIDEO S IV-D+ • 248
UMBILICAL 2CAM/ 2VIDEO/ UI FHCP DIGITAL • 273
UMBILICAL CAMERA CP4411E • 226
UMBILICAL CAMERA CP4412E BRAIDED • 227
UMBILICAL CAMERA CP4412E S IV-D • 229
UMBILICAL CAMERA MODULE 2CAM FHCP • 272
UMBILICAL CAMERA MODULE TO CABINET - 1 CAMERA • 241
UMBILICAL CAMERA MODULE TO CABINET - 2 CAMERA • 242

UMBILICAL CAMERA/ VIDEO 2CAM FHCP DIGITAL • 273
UMBILICAL CAMERA/ VIDEO CP4411E • 231
UMBILICAL CAMERA/ VIDEO CP4411E S IV-D • 230
UMBILICAL CAMERA/ VIDEO CP4412E S IV • 230
UMBILICAL CAMERA/ VIDEO CP4412E S IV-D • 228
UMBILICAL CONTROL BOX CP4412 • 234
UMBILICAL CONTROL BOX RT6 CP4410 • 215
UMBILICAL USER INTERFACE • 185
UMBILICAL VIDEO 1 CAT6 S IV-D • 243
UMBILICAL VIDEO 1 CAT6 S IV-D BRAIDED • 244
UMBILICAL VIDEO 2 CAT6 S IV-D • 243
UMBILICAL VIDEO 2CAT6 FHCP • 271
UMBILICAL VIDEO 3 CAT6 S IV-D CP4412E • 234
UMBILICAL VIDEO 4 CAT6 S IV-D+ • 244
UMBILICAL VIDEO SERIES IV • 234
UMBILICAL VIDEO SERIES IV-D CP4412E • 230
UMBILICAL VIDEO USER INTERFACE FHCP S IV-D • 271
UNINTERRUPTIBLE POWER SUPPLY (UPS) • 15
USER INTERFACE • 10
USER INTERFACE • 10

V

VGA BOARD • 20
VIDEO CABLE INTERCONNECT • 131
VIDEO CAT6 PPR2 S IV-D • 265
VIDEO MULTIPLEXER BOARD JUMPER SETTINGS • 84
VIDEO MULTIPLEXER BOARD JUMPER SETTINGS • 84
VISION PROCESSOR COMPUTER • 13
VISION PROCESSOR COMPUTER BOARDS • 19

W

WHAT'S NEW IN SERIES IV-D
INTELLISPEC? • 5

WIRING DIAGRAMS - PROCESSOR
CABINET S IV-D, D+ • 61